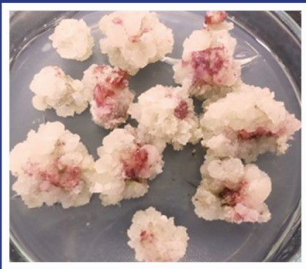


# AGRICULTURAL AND NATURAL RESEARCH & REVIEWS



**Editors**

**Prof. Dr. Birhan KUNTER**

**Assoc. Prof. Dr. Nurhan KESKİN**

**Agricultural  
Science**



LIVRE DE LYON

2021

# **Agricultural and Natural Research & Reviews**

**Editors**

**Prof. Dr. Birhan KUNTER**

**Assoc. Prof. Dr. Nurhan KESKİN**



**LIVRE DE LYON**

Lyon 2021

**Editors** • Prof. Dr. Birhan Kunter • Orcid: 0000-0001-5632-2955  
Assoc. Prof. Dr. Nurhan Keskin • Orcid: 0000-0003-2332-1459

**Cover Design** • Clarica Consulting

**Book Layout** • Mirajul Kayal

**First Published** • December 2021, Lyon

**ISBN:** 978-2-38236-228-0

**copyright © 2021 by Livre de Lyon**

All rights reserved. No part of this publication may be reproduced, stored in a retrieval system, or transmitted in any form or by any means, electronic, mechanical, photocopying, recording, or otherwise, without prior written permission from the Publisher.

**Publisher** • Livre de Lyon

**Address** • 37 rue marietton, 69009, Lyon France

**website** • <http://www.livredelyon.com>

**e-mail** • [livredelyon@gmail.com](mailto:livredelyon@gmail.com)



LIVRE DE LYON

## **PREFACE**

We undoubtedly know that Agriculture has the necessity for human existence. Agricultural development is a key to human well-being linked to the health of the environment. In modern times, agricultural materials and practices have been a challenging area for interdisciplinary studies. The very dynamic and great volume of agriculture has led us to write a book consisting of different scientific areas of plant science. With contributions by researchers from some universities of Türkiye, the presented book is designed as 14 chapters in agricultural and natural sciences.

Many scientific books have published in branches of agriculture and related areas addressing at different reader levels. We hope that the presented book containing reviews and researches will be a valuable source. In addition, this book also will serve as good reading topics in agricultural research area with those intending to inquire new subjects and results on agricultural and natural sciences.

During the book project we are thankful to the authors who shared expert knowledge in individual chapters. In particular, many special thanks to Prof. Dr. Abidin Temizer for the leading role in all steps in the process. Finally, we are grateful to publisher Livre de Lyon for their kind interest.

**Editors**





# CONTENT

	PREFACE	III
CHAPTER 1	IMPORTANT TURKISH WINTER PEAR CULTIVAR: 'ANKARA PEAR' (PYRUS COMMUNIS L.)	1
CHAPTER 2	MAJOR PHYSIOLOGICAL DISORDERS AND MANAGEMENT IN EUROPEAN PEAR (PYRUS COMMUNIS L.) DURING POSTHARVEST PERIOD	21
CHAPTER 3	PRUNING OF NON-FEATHERED NURSERY-PRODUCED APPLE, WALNUT AND SWEET CHERRY TREES IN THE FIRST AND SECOND LEAF: LESS KNOWN GENOTYPE-SPECIFIC APPROACHES	39
CHAPTER 4	POLLINATION AND FRUIT SETTING IN OLIVE (OLEA EUROPEAE L.)	59
CHAPTER 5	LED LIGHTING AND ROBOTIC ARM TECHNOLOGIES FOR PLANT PRODUCTION	79
CHAPTER 6	EFFECTS OF COLCHICINE ON IN VITRO REGENERATION AND PLOIDY LEVEL IN GRAPEVINE (VITIS VINIFERA L.)	99
CHAPTER 7	A REVIEW ON PRODUCTION OF SECONDARY METABOLITES IN GRAPEVINE BY CALLUS CULTURE	115
CHAPTER 8	AN IMPORTANT VALUE 'KARAERİK' GRAPE CULTIVAR (VITIS VINIFERA L.): AN OVERVIEW OF IT WITH STUDIES IN THE LIGHT OF LITERATURE	135


CHAPTER 9	GRAPE YIELD, QUALITY AND NUTRITIONAL STATUS OF 'EARLY CARDINAL' ( <i>V. VINIFERA</i> L.) IN RESPONSE TO GROWTH SUBSTRATE AND FERTILIZER APPLICATIONS IN SOILLESS CULTURE	149
CHAPTER 10	CULTIVATION OF TABLE GRAPES IN SOILLESS CULTURE SYSTEM	173
CHAPTER 11	RAISINS	193
CHAPTER 12	COMPOSITION OF RAISIN, ITS IMPORTANCE FOR HEALTH AND USAGE OF GRAPE IN FOLK MEDICINE	215
CHAPTER 13	SUSTAINABLE AGRICULTURE AND GENETICALLY MODIFIED ORGANISMS (GMOs)	233
CHAPTER 14	MODELLING OF DEPENDENCY STRUCTURE AMONG REPEATED MEASUREMENT USING SAS'S PROC MIXED PROCEDURES	255


# CHAPTER 1

## IMPORTANT TURKISH WINTER PEAR CULTIVAR: ‘ANKARA PEAR’ (*PYRUS COMMUNIS* L.)

Hatice DUMANOĞLU<sup>1</sup>✉ & Nurdan TUNA GUNES<sup>2</sup>  
Özge HORZUM<sup>3</sup>

<sup>1</sup>(Prof. Dr.), Ankara University, Faculty of Agriculture,  
Department of Horticulture, Ankara, Türkiye,  
e-mail: dmanoglu@agri.ankara.edu.tr  
 0000-0002-7099-7630

<sup>2</sup>(Prof. Dr.), Ankara University, Faculty of Agriculture,  
Department of Horticulture, Ankara, Türkiye,  
e-mail: tuna@agri.ankara.edu.tr  
 0000-0002-8529-2211

<sup>3</sup>(Dr.), Ankara University, Faculty of Agriculture,  
Department of Horticulture, Ankara, Türkiye,  
e-mail: ozupek@agri.ankara.edu.tr  
 0000-0003-2030-5613

### 1. Introduction

**P**ear (*Pyrus communis* L.) has an important place in pome fruit species. It can be grown in all temperate climate regions of the world, in some countries with tropical and subtropical climates, in high altitude areas. (Jackson 2003). According to USDA Food Data Central database, 100 g pear fruit contains 84.1 g water, 63 kcal energy, 0.06 g nitrogen, 0.38 g protein, and 0.16 g total lipid. Total dietary fiber is 3.1 g 100 g<sup>-1</sup> fresh weight (FW), total sugar content is 9.69 g 100 g<sup>-1</sup> FW. Fructose is the highest level (6.76 g 100 g<sup>-1</sup> FW). Potassium (87 mg 100 g<sup>-1</sup> FW) is abundant mineral and followed by phosphorus (10 mg 100 g<sup>-1</sup> FW), calcium (8 mg 100 g<sup>-1</sup> FW), magnesium (5.7 mg

100 g<sup>-1</sup> FW). Other trace elements are iron, zinc, copper, manganese, selenium. Moreover, this fruit includes vitamin C as total ascorbic acid (4.4 mg 100 g<sup>-1</sup> FW) and aspartic acid (0.104 g 100 g<sup>-1</sup> FW) (FDC 2021). These nutritional characteristics make this fruit a product preferred by consumers. Additionally, juicy and sweet fruit flesh, as well as its unique aroma, is an important factor in the preference of the fruit by the consumers.

In 2019, global pear production was 23,919 million ton. China, Italy and USA were biggest producers until 2019, the main producers ordered as China, USA, Argentina and Türkiye. Türkiye produced 530,723 tons and supported 2.2% of global production in that year and in recent years, Türkiye presented a regular increase trend in pear production (FAO 2021). Number of bearing pear trees increased at a rate of 17.4%, number of non-bearing trees increased at a rate of 34% in Türkiye between 2010 and 2020. Increase rate was 28.7% in pear growing area, and 21% in yield. Naturally, the increase in production amount was 43.6% (TÜİK 2021). Similarly, pear export amount of Türkiye has increased 3.7-fold and reached to 64,585 tons since 2016. The most important importer countries were Russian Federation, Iraq, Romania, Bulgaria, Israel and Germany (ITC 2021).

According to Janick and Paull (2008), there are more than 5000 pear cultivars in the world but commonly grown cultivars can vary based on the countries. Türkiye has a lot of pear cultivars, the most common cultivars are ‘Deveci’, ‘Santa Maria’, ‘Ankara’, ‘Akça’ ve ‘Bartlett’. Within these cultivars, ‘Ankara’ pear fruit has a special place with its distinctive aroma and taste, and long period storage possibility, as well. It is possible to find fruit of this cultivar on market shelf during long winter period. This chapter explains plant characteristics and growing conditions, orchard management as well as pest and diseases, postharvest handling characteristics of ‘Ankara’ pear cultivar.

## **2. Plant Characteristics**

### ***2.1. Morphology***

The Ankara pear plants grow upright producing columnar shape as other pear trees (Figure 1). Main (primary) branches are sparse while laterals are dense. The trunk and old branches are light gray. Trees have varying degree of vigor depending on the rootstock. Trees on pear and wild pear rootstocks have semi-vigorous and vigorous growth, and the height and diameter of the trees on these rootstocks are about 5-6 m. Trees have weak growth on clonal dwarfing quince rootstocks, plant height is about 3-4 m and plant diameter is about 1.0-3.5 m



(Figure 2). Tree has two kinds of branches, vegetative and fruiting (Figure 3) (Oraman 1947).

Vegetative branches are divided into wood branches and water sprouts which carry vegetative buds on them. When these buds open they form leaves or shoots. Water sprouts arise from the dormant (latent) buds on the trunk of a tree or from branches that are several years old. The structure of a water sprout is less woody, and the distance between the buds on them is longer than the wood branches. Generally, they grow upright vigorously and cause crowded canopy. Since they prevent sunlight entering into the canopy they are usually cut and removed from the tree during dormant season. Wood branches form the framework of the tree, carrying wood and fruiting branches. Fruit branches are one or two years old or older branches. They can be found on the trunk, on two years old or older branches on the tree. Old fruit branches are usually short. Fruit branches could be a year-old that they are usually long and the fruits are formed at the tip (Özbek 1947) (Figure 3).



Figure 1. The appearance of a pear tree having a vertical growth habit



Figure 2. Dwarf 'Ankara' pear trees grafted on quince rootstock planted with 1.5 m distances between the trees in the rows



Figure 3. The wood and fruit branches, and developing fruit buds in 'Ankara' pear cultivar

Vegetative and fruit buds could be on short and long fruit branches. The flower buds are mixed that when the fruit buds open, flowers in form of a cluster and leaves or a shoot emerge (Figure 3). Wood buds are slender and the tip is pointed. Flower buds are round, swollen, plump, and the tip is slightly pointed (Özbek 1947, 1978).

The leaves are small, ovoid (egg-shaped), completely symmetrical, leathery. The upper surface is dark green and the lower surface is light green. The both surfaces are hairless and smooth. Leaf margin is slightly serrated. Petiole is long (Kiper 1937, 1941; Oraman 1947; Özbek 1947).

A flower cluster (a cyme) in a flower bud may consist of 3 to 9, with an average of 7, individual flowers. The flowers are of medium size (Dokuzoğuz 1964).

## 2.2. Fruit

The fruit is medium-large to large, round, regular and with somewhat flat calyx end. The fruit is 6.5-7.5 cm in diameter, 6.0-6.5 cm in length, and an average of 150 grams in weight (Figure 4). Some fruits, however, may reach to a quite large size of about 300-500 grams in weight. The stem is short between 1.5 - 2.0 cm in length and medium thick. The stem-end depth which is located opposite the stalk cavity is small (Anonymous 1993).

The skin is thin, soft, slightly rough, wax-free and slightly shiny. Skin color is green to dark green at harvest but changes into yellowish-green to yellow during ripening. The flesh is cream in color, very juicy and sweet, and melts in the mouth without grits and fragrant. The core is small with 5 carpels. The seeds are large, about 10 mm long, elongated with pointed tip, margins are dark brown and the center is light brown (Oraman 1947; Özbek 1947).

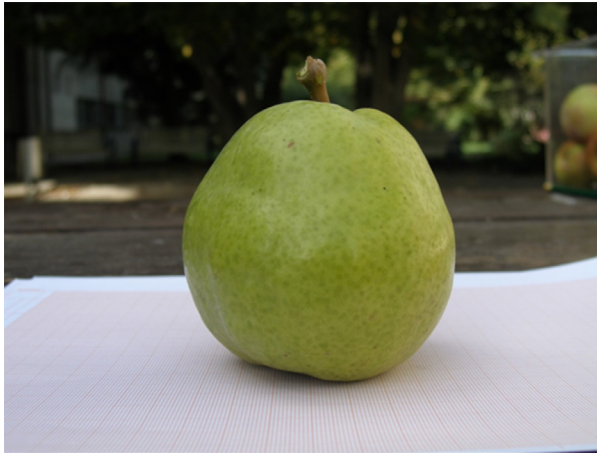


Figure 4. The fruit of 'Ankara' pear

## 2.3. Biology

'Ankara' pear is self-incompatible meaning that its own pollen cannot fertilize the pistil, thus another cultivar is needed for the fruit set. However, depending on the ecological conditions, parthenocarpy can be observed resulting in seedless fruits without pollination in some years. But the parthenocarpy may not be a continual event. A pollinizer cultivar should be planted at a rate of 1/8 in Ankara

pear orchards in order to get regular crop every year. The pollinizer cultivar should be compatible, bloom regularly every year, produce plenty of highly viable pollen with high germination rate. The blooming period should overlap with that of 'Ankara' pear trees. The flowers are pollinated with honeybees like other pears. Two to three beehives per hectare should be placed for a good fruit set during blooming in the orchard (Özbek 1947; Dokuzoğuz 1964).

#### **2.4. Phenology and Yield**

The budburst date of flower buds varies by years, but it is usually the second week or soon after in March in Ankara. Green-tip stage usually occurs by late March to first week of April. Blossoms, which are at the first white stage in the first or second week of April, begin to open in the middle or second half of April. Full bloom stage is reached by 4-5 days later, and the blooming is completed towards the end of April. In some years, flowering phenology may be earlier or delay for about one to two weeks depending on the weather conditions in some years (Dokuzoğuz 1964; Bıyık 1993).

The fruits are commercially harvested in late September to early October in Ankara. The time of leaf fall varies between mid-November and early December. Fruit set ratio may be variable based on the years and rootstocks used. The fruit set being higher in one year and lower in the subsequent year may indicate that 'Ankara' pear is partially sensitive to alternate bearing which can be prevented by regular fertilization, irrigation, pruning and fruit thinning. On the other hand, 'Ankara' pear is a productive cultivar (Özbek 1947). On pear and wild pear rootstocks, trees begin to yield at the age of five to seven years. The yield increases until the age of fifteen. In well managed orchards, productivity continues at about the same level until the age of 50 and then declines. On quince rootstocks, trees begin to produce at the age of 3 or 4 years and reach to full potential at the age of 10 years. Productivity continues until the age of 30-35 in good orchard management conditions. The average yield on large trees grafted on strong rootstocks ranges from 40 to 150 kg per tree and from 8.000 to 30.000 kg per one hectare. On dwarfing rootstocks, the average yield is between 25 and 60 kg per tree and 20.000-50.000 kg per hectare (Çelik 1988).

### **3. Growing Conditions of Ankara Pear Cultivar**

#### **3.1. Climatic requirements**

Ankara pear trees produce high quality fruits in climates with summers having plenty of sunshine, hot, arid, airy and low humid air conditions. The province of

Ankara has ideal climatic conditions for the cultivation of this pear. Long term meteorological data of Ankara province indicate that the average temperature is between 20 and 32°C, relative humidity is between 43 and 52%, total of rainfall is 50 mm, and total of cloudy days is below 2.5 days in summer months (Özbek 1978). These climate conditions, especially the low relative humidity, offer great potential for growing 'Ankara' pear successfully. Late spring frosts occur in blooming period or small fruit stage, and may cause serious crop losses especially in orchards established on low or flat lands in Ankara province. There is a risk of late spring frosts until mid-May in Ankara. Fully opened flowers are damaged by low temperatures at -2.2°C and small fruits at -1.1°C. Although the trees can withstand low temperatures up to -25 and/or -30 °C during deep dormancy in winter extended period of severe frosts can damage the shoot tips. 'Ankara' pear cultivar has a minimum chilling requirement of 750 hours at temperatures between 0 and 7.2°C in order to break the buds in spring. Ankara province provides about 2000 hours of chilling (Ünver 1994). Insufficient chilling may result in delayed, uneven and extended flowering periods of leading directly to poor fruit set and low productivity (Özbek 1947 1978; Westwood 1993).

### 3.2. *Soil requirements*

The soil requirement of the 'Ankara' pear cultivar differs by the rootstocks. While the trees adapt well to arid conditions on wild pear rootstock the trees on pear or quince rootstocks need soil to have sufficient amounts of moisture. In general, the tree development is good and the productivity is high in deep, permeable, warm and nutrient-rich soils. The fruits develop irregular shape and gritty flesh in very dry, shallow and stony soils. Heavy and moist soils cause rough and tasteless flesh formation, delayed maturity and decreased storage life. The trees especially grafted on quince rootstocks develop lime induced iron chlorosis in high lime soils (Kiper 1941; Oraman 1947; Özbek 1947, 1978).

## 4. Propagation and Orchard Establishment of Ankara Pear Cultivar

### 4.1. *Propagation*

Ankara pear trees are propagated by budding/grafting. Most widely used rootstocks are pear, wild pear and quince (Çelik 1988; Westwood 1993).

**Pear (*Pyrus communis* L.) rootstocks:** Old Home x Farmingdale 333 (OHxF333) is the most widely used clonal pear rootstock in Türkiye. OHxF333



is a semi-dwarf rootstock developed in the United States for its tolerance to fire blight and pear decline diseases. It is propagated by tissue culture. Pear seedlings are another pear rootstock. Ankara pear trees grow vigorously on pear seedlings. In general, pear rootstocks on which Ankara pear trees grafted are preferred in deep, permeable and nutrient-rich soils.

**Quince (*Cydonia oblonga* Mill.) rootstocks:** There is no graft incompatibility between 'Ankara' pear cultivar and quince rootstocks. Quince rootstocks reduce the vigor and the height of the grafted trees that they develop dwarf plants (Figure 2). Quince A and BA29 are the most commonly used rootstocks in Türkiye. These are clonal rootstocks. They are propagated by mound layering, cutting and tissue cultures. Quince seedlings are sometimes used as rootstock for pears. Quince rootstocks have shallow root system that they can grow in shallow soils. Quince plants can be used as a rootstock for Ankara pear in not too heavy, sandy-loamy, moderately moist and warm soils. They are not resistant to drought and extreme cold temperatures. In calcareous soils, Ankara pear plants grafted on quince rootstocks develop serious chlorosis problems. In the case of chlorosis, soil or foliar applications are expensive and do not have long lasting effect. Thus, quince plants should be preferred as a rootstock in soils without high lime, rich in organic matter, with good physical properties and no irrigation problems (Anonymous 1998).

**Wild pear (*Pyrus elaeagnifolia* Pall.) rootstocks:** Wild pear trees which are naturally found in the barren and mountainous areas of Central Anatolia have a good adaptability to especially dry climates and conditions due to their deep root system (Kiper 1941). Thus, they have been grafted and used as rootstock for 'Ankara' pear and other pear cultivars since ancient times. Wild pear plants are also resistant to high lime induced chlorosis. 'Ankara' pear trees grafted on wild pears show medium to vigorous growth. Wild pear plants are seedling. Pears are grafted on wild pear plants grown from seeds or on the naturally grown plants brought from mountainous and rural areas in the nurseries. In addition, young or mature wild pear plants are grafted onsite with pear cultivars.

As in other pear cultivars, the nursery plants of 'Ankara' cultivar should be free especially from common diseases and pests such as fire blight and nematodes (Westwood 1993). Care should be taken to use certified nursery plants when the orchard establishment. Certified plants labelled with blue color are verified that they are true to name and free from pest and diseases (Anonymous 1998). The growers who use this certified and labelled plants for orchard establishment are eligible for incentives.

## 4.2. Orchard establishment

Grafted plants with one or two years old are preferred for planting. Planting layouts between trees can be square or rectangular arrangement. Distances between the tree rows and between the plants in a row are determined by the rootstock used and the training system applied (Westwood 1993). In standard 'Ankara' pear orchards, distances of 6x6 m, 6x7 m and 7x7 m on strong rootstocks (seedlings of pear or wild pear), 3x4 m and 4x4 m on semi-dwarf rootstock (OHxF333) and 1.5x 4 m, 2x4 m and 2.5x4 m on dwarfing quince rootstocks (Quince A and BA29) are used between the plants in rows and between the rows, respectively. Number of trees planted at 6x7 m distances on pear seedling rootstocks is 230-240 per one-hectare orchard. However, on dwarfing quince rootstock, 1000 plants are planted at 2.5x4 m distances per one-hectare orchard. In high density orchards, permanent support systems are used. The distance between trees in the rows can be reduced up to 1.2 m. The distance between the rows is 4 m. The distance between the plants on wild pear rootstocks in barren areas can be increased up to 10-15 m. For cultivation in drought conditions with no irrigation, either three wild pear seeds should be sown in each hole or seedling plants should be planted in their places in the orchard in order to develop deep and strong root system. The plants should be grafted onsite when the seedlings' stems reach to desired thickness. One or more pollinizer cultivar should be planted for cross pollination and good fruit set that one tree of the pollinizer to eight of 'Ankara' pear trees should be placed in the orchards (Çelik 1988).

## 4.3. Planting

The time to plant bare root plants is dormant season from leaf fall in autumn to bud break in spring. Planting before bud break in spring is suggested in areas with harsh winters (Özbek 1978). Plants in containers such as pots or plastic bags can be planted all year round. Plants should be carefully removed from the container keeping the soil around the roots intact and planted immediately. Bare root trees should be planted before the bud swell in spring. Autumn plantings give better results in arid regions provided that the winters are not too harsh since the roots continue to grow at soil temperatures above 0°C during fall and winter (Özbek 1978). Thus, capillary root formations are completed until spring and plants start to grow with good water balance which decreases the risk of dying. The roots of bare root trees are pruned before planting. The purpose is to remove the damaged, crushed and broken root parts at the healthy spot caused by plant removal from nursery beds, and to remove the roots that overlap each

other. Nursery plants grown in containers are planted with soil, and root pruning is no performed (Anonymous 1998).

Canopy pruning is also carried out on plants planted in dormant season. Canopy pruning is applied to create a balance between the canopy and the root system, to train the canopy and to eliminate apical dominance in plants that are not yet branched (Westwood 1993). If lateral branching is not sufficient, all of the branches are cut leaving four to five forks. If the plant is one-year-old and has no branches, then it is headed off at 75-80 cm above graft union. The plants with a height below 70 cm is left as it is (the top is not headed) that it is allowed to reach sufficient height during the season. If the top of small plants is headed, the branches will develop at very low levels. Unpruned plants start to grow fast with the help of nutrients stored in the buds and the trunk in the spring. But, they begin to dry since the roots are not yet able to meet the water needs of new shoots and leaves. Survived unpruned plants may grow but their shoots will not be strong and remain bare since lower buds do not grow, and the shoots become unstructured and unfruitful. These plants take couple of years to recover. Planting holes should be drilled 1-3 months before planting if possible. The soil is aerated and inner walls of the hole soften until planting, thus creates a suitable environment for better root growth. In practice, however, the holes are usually drilled just before the planting. Truck mounted augers or hand operated motorized augers can be used for drilling the holes. The depth and width of the hole should be minimum of two times the root volume that the holes with 40 to 60 cm width and depth are suitable. Well composted manure should be used for tree planting. The use of fresh, non-composted manure is very risky that larvae of insects feed on the roots and give serious damages, and even cause plant losses. Three to five shovels of composted manure are sufficient for each planting hole. In addition, 75 to 100 grams of each of nitrogen (Diammonium Phosphate, DAP) and phosphorus (Triple Superphosphate, TSP) fertilizers are also placed in the holes. Manure and chemical fertilizers are mixed with the soil in the hole and a form of dome shape is given. The roots are placed over the dome. At this stage plant's graft union should be 8-10 cm above the soil level. The hole is filled halfway and the soil is pressed by foot so that the roots come into contact with the soil. After completely filling the hole the soil is pressed again. A water-holding basin is created around the hole and irrigation is done immediately and then repeated. A stake is driven upright into the ground and the plant is secured by tying to the stake. The most important point is to avoid deep planting. Nursery plants with buried graft union in the soil develop chlorosis disorder later.

## **5. Orchard Management**

### **5.1. Soil cultivation**

'Ankara' pear orchards should be plowed at a depth not more than 15 cm after the harvest in the fall for the soil to benefit from the winter precipitation (snow and rain) at a maximum rate. The soil with large clods are left as it is. The deeper plowing can damage the roots. Spring tillage is done as shallow cultivation at a depth of 8-10 cm with cultivators or disk harrows when the soil is dry enough to work with in February-March. Shallow cultivation is carried out with cultivators (such as rotary tiller) and hoeing machines especially for weed control during the summer (Özbek 1978).

### **5.2. Fertilization**

Fertilization is of great importance for getting healthy plant development, increased yield and fruit quality fruit in 'Ankara' pear trees. For fertilization, soil samples should be taken in the orchards and sent to the lab for fertility analysis after the harvest. According to soil analysis results, an organic material of well composted manure, compost or organic material from other sources should be applied at a rate of 30-40 tons per hectare in the fall every 3 years in order to making better use of water and nutrients by improving the physical structure of the soil and to support the soil to a certain extent in terms of nutrients (Özbek 1947, 1978). Organic material could be in solid or liquid form. Solid organic material should be spread over the soil into the tree canopy projections after the harvest, and should be mixed into the soil during mechanical cultivation. If necessary, indicated by soil analysis results, phosphorous fertilizers preferably as TSP (Triple Superphosphate) should be applied in 15-20 cm depth to the canopy projection of the trees and should be covered. Half amount of the nitrogenous fertilizers, indicated by soil analysis results, preferably ammonium sulfate should be surface-applied to the canopy projection during dormant season before bud burst in March, and the other half should be applied in June. The fertilizer should be covered with soil immediately to prevent nitrogen from escaping into the air. Water soluble forms of fertilizers can be applied with drip irrigation. Foliar applications may be used for nutrients such as iron, zinc and boron during the spring-summer growing period (Westwood 1993).

### **5.3. Irrigation**

'Ankara' pear orchards should be irrigated adequately from May to mid-September in 'Ankara' conditions. Drip irrigation technique should be used for

saving water and irrigation efficiency. Irrigation is recommended when 50% of the available water in the root zone is taken up by the plant, in other words, when the available water holding capacity drops to 50% (Westwood 1993).

#### **5.4. Pruning and training**

Modified central leader is a suitable training system for 'Ankara' pear trees. This system consists of a leader branch in the center and 3-5 scaffold branches (Özbek 1978) (Figure 5).

The plant is headed back 75-80 cm above the graft union just after planting. Young shoots are formed by the buds just below the pruning cut after the plant growth starts in spring. At the end of the first year, the strongest upright shoot at the top should be selected as the leader, and 3-5 shoots developed from the lower parts distributed evenly around the trunk and spaced at 10-15 cm distances facing to different directions are selected for scaffold limbs. These scaffolds should have the crotch angle of 45-60° with the leader, and remaining branches should be removed. Secondary branches are allowed on the scaffolds in the following year. It should be ensured that the scaffolds are developed outwards, not in to the canopy. For early fruiting the excessive cuts should be avoided at the tip of the branches, outward facing branches should be selected and the crotch angles should be widened during the pruning (Westwood 1993). Pruning should be done regularly every year during the dormant season for a good yield and tree growth in mature 'Ankara' pear trees. Dead, unproductive-weak branches and sprouts, if exist, causing crowded inner canopy should be removed during pruning. The fruits are generally formed on short fruit branches called spurs in 'Ankara' pear trees. Economic life these branches is 3-10 that they should be retained on the tree. Rejuvenation pruning is a canopy renewal in trees that have declined in fruit production and vegetative growth. It is appropriate to extend the rejuvenation pruning to 2-3 years since severe and deep cuts are made.

#### **5.5. Fruit thinning**

Excess amounts of fruits should be removed in heavy crop years in 'Ankara' pear trees. Thinning should be applied at latest in June when the fruits reach the diameter of 1 cm. Maximum of 2 fruits on each cluster or one fruit per every 20-30 leaves should be left on the tree to increase the size and quality of the remaining fruits on the tree. Regular crop is also warranted every year by thinning (Westwood 1993).



### 5.6. Pest and disease management

Some of these diseases and pests all pear cultivars as well as for 'Ankara' pear cultivar are listed below (Anonymous 2016).

Some important diseases: Fire blight (*Erwinia amylovora*), pear scab, European pear rust, apple powdery mildew

Some important pests: Aphids, pear psylla, codling moth, apple blossom beetle



Figure 5. A pear tree trained with modified central leader system

## 6. Harvest, Postharvest Handling and Storage

Studies on optimum harvest time and/or storage performans of 'Ankara' pear fruit firstly begun with Prof.Dr. Mustafa Pekmezci in 1975. As in other fruit species, 'Ankara' pear fruit should be harvested at the optimum maturity stage to prolong cold storage period, minimize losses and retain the fruit quality as in other fruit species and cultivars. Harvest maturity indices of Ankara pear as follow; fruits' respiration rate is 13-15 mL CO<sub>2</sub> kg<sup>-1</sup>h<sup>-1</sup>, flesh firmness is 56.5

N-69.4, total soluble solids content is 11.7-14.3% and the amount of titratable acidity is 0.28-0.59% malic acid equivalent (Pekmezci 1975; Tuncel & Köksal 1986) (Figure 6). The days number after full bloom, which is another harvest criterion, varies between 145 and 165 days depending on the location and the years (Tuncel & Köksal 1986).

The fruit should be harvested with stem after drying the dew on the fruit in the morning. After harvest, the fruit should be placed in clean and dry containers without mechanical damaging, and brought to packaging or storage facility.

After harvest, the metabolic activity of 'Ankara' pear fruit increases during ripening period as in other pear cultivars (Saquet & Almeida 2017). Pekmezci (1975) reported that respiration peak reached to 17.9-19.9 mL CO<sub>2</sub> kg<sup>-1</sup>h<sup>-1</sup>, flesh firmness decreased to 20.0 N-36.9 N and soluble solids content increased to 14.8-15.2% in 'Ankara' pear fruit which were kept for 17-25 days at room temperature for ripening after harvest. The same research indicated that the fruits retain normal taste and sufficient ripening level until the day-191 (about 6 months) in cold storage at 0 °C and 85-90% relative humidity conditions. Later, however, fruits develop bitter taste and are not able to ripen normally. But, this problem can be overcome by storing the fruits in controlled atmosphere storage conditions.



Figure 6. Ankara pear fruits before the harvest

The cold storage period of 'Ankara' pear fruit can change depending on ecology, rootstocks and genotypes (Dumanoğlu *et al.* 1993; Güneş *et al.* 2007). The storage period at 0 °C, regular air conditions was reported as long as 3-4 months for the fruit grown Mediterranean Sea region (Kurubaş & Erkan 2018). This period under the same storage conditions was at least six months for the fruit

grown Central Anatolia region. However, after longer storage period than six months, the fruit could not regain its ripening ability (Pekmezci 1975; Bakoğlu & Tuna Güneş 2014). Even if the fruit could ripe properly, sometimes it has been bitter taste without flavor (Bakoğlu & Tuna Güneş, 2014; Güneş *et al.* 2007). Common physiological disorders in pear fruit such as flesh browning, skin scald etc. which are extensively mentioned for other European pear cultivars are not a problem 'Ankara' pear fruit (Pekmezci 1975; Tuncel & Köksal 1986; Güneş *et al.* 2007; Bakoğlu & Tuna Güneş 2014). It means that the fruit of this cultivar isn't sensitive physiological disorders and this is a positive characteristic rather than long storage period under regular air storage conditions at 0 °C. This can be resulted from low polyphenol oxidase activity in fruit flesh (Bakoğlu & Tuna Gunes 2020).

For today, there are a lot of postharvest technology such as controlled atmosphere (CA) storage, modified atmosphere packaging (MAP), 1-methylcyclopropene (1-MCP) treatments used for maintaining quality in pear fruit after harvest. For 'Ankara' pear fruit, the optimum CA storage conditions are 3 % O<sub>2</sub> + 1.5 % CO<sub>2</sub> at 0 ±1 °C for at least a storage period of seven months (Demirci 2003).

As an ethylene antagonist, 1-MCP helps to delay fruit senescence with a longer storage and shelf life periods in most of the horticultural commodities (Watkins 2015). Moreover, it can retard ethylene biosynthesis, perception and respiration, and decrease loss in firmness and color in pear fruit after harvest (Mwaniki *et al.*, 2005; Trincherro *et al.* 2004; Villalobos-Acuna *et al.*, 2011a, 2011b). The severity of 1-MCPs' effects and 1-MCP concentrations can vary based on cultivars (Watkins 2015). For 'Ankara' pear fruit, 1-MCP concentrations for regular air storage conditions at 0 °C temperature can depend on ecological factors during fruit growth and development. For fruit from Mediterranean Sea region, 0.5 µL L<sup>-1</sup> 1-MCP can serve fruit quality maintaining during eight months at 0 °C temperature in regular air conditions (Kurubaş & Erkan 2018). However, for fruit from Central Anatolian Region, satisfactory 1-MCP concentrations are 0.15 µL L<sup>-1</sup> for a storage period of 200 days and 0.3 µL L<sup>-1</sup> for a longer storage period under regular air storage conditions at 0 °C, respectively (Bakoğlu & Tuna Güneş 2014).

The shelf life period of 'Ankara' pear fruit can reach to 15 days after long term cold storage either in regular air at 0 °C, and CA storage conditions (Bakoğlu & Tuna Güneş 2014; Horzum & Tuna Gunes 2021). CA storage (3%O<sub>2</sub> + 1.5%CO<sub>2</sub>) and 1-MCP treatment (0.3 µL L<sup>-1</sup>) can individually help to keep skin and flesh color, health benefits such as antioxidant scavenging capacity and

vitamin C content in ‘Ankara’ pear fruit, however, combined effects of these technologies are not significant (Figure 7). It means that if there is CA storage possibility, it is not necessary to treat the fruit with 1-MCP for keeping quality parameters for a long time at least 200 days at 0 °C.

The fruits are mostly consumed fresh fruit; however, ‘Ankara’ pear fruit can also be processed into dried, frozen and mashed products as well as molasses, pear juice, cream, carbonated drinks, and can be used in pastry and dessert industry.

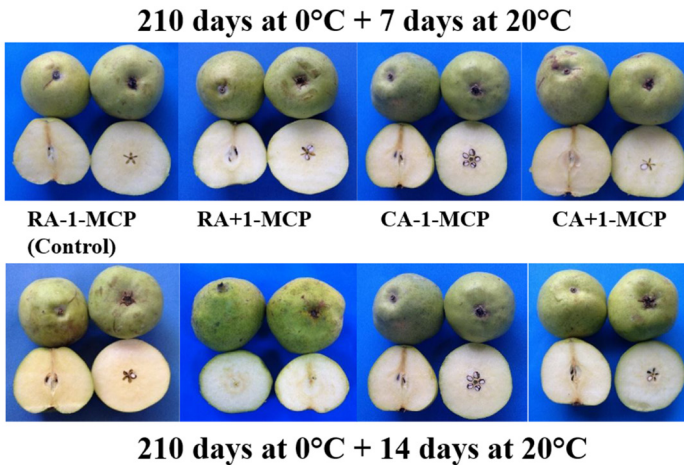


Figure 7. The appearance of ‘Ankara’ pear fruit during shelf life period. RA: Regular air storage at 0°C, CA: Controlled atmosphere storage at 0°C

## References

- Anonymous (1993). Armut Çeşit Kataloğu. T.C. Tarım ve Köyişleri Bakanlığı Yayın Dairesi Başkanlığı. Ankara. 48s.
- Anonymous (1998). Fidan Üretim ve Dağıtım Talimatı (1998-1999). T.C. Tarım ve Köyişleri Bakanlığı Tarımsal Üretim ve Geliştirme Genel Müdürlüğü. Ankara. 360p
- Anonymous (2016). T.C. Gıda Tarım ve Hayvancılık Bakanlığı. Gıda ve Kontrol Genel Müdürlüğü. Armut-Ayva Hastalık ve Zararlıları ile Mücadele. [https://www.tarimorman.gov.tr/GKGM/Belgeler/Uretici\\_Bilgi\\_Kosesi/Dokumanlar/armut-ayva.pdf](https://www.tarimorman.gov.tr/GKGM/Belgeler/Uretici_Bilgi_Kosesi/Dokumanlar/armut-ayva.pdf) (Accessed date: 09/15/2021)
- Bakoğlu N & Tuna Gunes, N (2020). The effect of 1-MCP concentration on skin and flesh color polyphenol oxidase activity during cold storage and shelf life periods in ‘Ankara’ pear (*Pyrus communis* L.). *Acta Horticulturae* 1275, 221–228

- Bakoğlu N, & Tuna Güneş N (2014). 'Ankara' armudunda 1-metilsiklopropen'in bazı derim sonrası kalite parametrelerine etkisi. VI. Bahçe Ürünlerinde Muhafaza ve Pazarlama Sempozyumu, 22-25 Eylül 2014, Bursa, Bahçe Bilimi Yayın No 5, 60–67
- Bıyık N (1993). Seçilmiş S.Ö. Ayva anaçları üzerine aşılı Ankara, Akça, Şeker ve Williams armut çeşitlerinin fenolojik ve Pomolojik özellikleri. Yüksek Lisans Tezi (Yayınlanmamış). Ankara. 80p
- Çelik M (1988). Ankara koşullarında Williams, Ankara, Akça ve Şeker Armut çeşitleri için en uygun S.Ö. ayva anaçlarının seçimi üzerinde bir araştırma. Ankara Üniversitesi Ziraat Fakültesi Yayınları, 1075. Ankara. 24p
- Demirci T (2003). Changes of some quality characteristics of Ankara pear cultivar stored at controlled atmosphere. MSc Thesis. Ankara University, Graduate School of Natural and Applied Sciences, Department of Horticulture, Ankara, 62p
- Dokuzoğuz M (1964). Bazı önemli armut çeşitlerinin dölleme biyolojisi üzerinde araştırmalar. Ege Üniversitesi Ziraat Fakültesi Dergisi, 1(2): 68-84. (Ayrı basım).
- Dumanoğlu D; Tuncel, N ; Çelik, M & Ayfer, M (1993). Farklı S.Ö. Ayva Klon Anaçları Üzerine Aşılı Ankara Armudu Meyvelerinde Soğukta Muhafaza sırasındaki kalite değişimleri. Gıda 18(1): 45-49.
- FAO (2021). Food and Agriculture Organization of the United Nations. <http://www.fao.org/faostat/en/#data/QCL> (Accessed date: 08/20/2021).
- FDC (2021). U.S. Department of Agriculture. FoodData Central. Pears, raw, Bartlett. <https://fdc.nal.usda.gov/fdc-app.html#/food-details/746773/nutrients> (Accessed date: 08/06/2021)
- Güneş N T; Şan B; Aygün A; Erdoğan V; Kotlarla A & Dumanoğlu H (2007). Cold storage of promising 'Ankara' pear fruit clones. V. National Horticultural Congress, Proceedings Book. Volume 1, 469–473, Erzurum, Türkiye
- Horzum O & Tuna Gunes N (2021). Storage type and 1-methylcyclopropane can alter keeping of color, vitamin C and antioxidant capacity in 'Ankara' pear (*Pyrus communis* L.). XIII International Controlled and Modified Atmosphere Research Conference. 16-18 August 2021, Leuven Belgium. Acta Horticulturae (In Press)
- ITC (2021). Trade statistics for international business development. TRADE MAP. [https://www.trademap.org/Country\\_SelProduct\\_TS.aspx?nvpm=1%7c%7c%7c%7c%7c%7c080830%7c%7c%7c6%7c1%7c1%7c2%7c2%7c1%7c2%7c2%7c1%7c1](https://www.trademap.org/Country_SelProduct_TS.aspx?nvpm=1%7c%7c%7c%7c%7c%7c080830%7c%7c%7c6%7c1%7c1%7c2%7c2%7c1%7c2%7c2%7c1%7c1) (Accessed date: 09/15/2021)



- Jackson J E (2003). *Biology of Apples and Pears*. Cambridge University Press, Cambridge, UK, 488p
- Janick J & Paull R E (2008). *The Encyclopedia of Fruit and Nuts*. CAB International, Cambridge University Press, Cambridge, UK. 954p
- Kiper N Ö (1937). Ankara-Eskişehir-Çankırı vilayetlerinde meyvecilik ve bilhassa armut çeşitlerinin morfolojik ve biyolojik tetkikatına ait rapor. Yüksek Ziraat Enstitüsü Neşriyatı Umumi Sayı: 101. Ankara. 32p
- Kiper N Ö (1941). Orta Anadolu armutçuluğu ve mühim armut çeşitleri. Yüksek Ziraat Enstitüsü Çalışmalarından. Sayı 123. Ankara. 98s.
- Kurubaş M S & Erkan M (2018). Impacts of 1-methylcyclopropene (1-MCP) on postharvest quality of ‘Ankara’ pears during long-term storage. *Turkish Journal of Agriculture and Forestry* 42: 88–96
- Mwaniki M W; Mathooko F M; Matsuzaki M; Hiwasa K; Tateishi A; Ushijima K; Nakano R; Inaba A & Kubo Y (2005). Expression characteristics of seven members of the  $\beta$ -galactosidase gene family in ‘La France’ pear (*Pyrus communis* L.) fruit during growth and their regulation by 1-methylcyclopropane during postharvest ripening. *Postharvest Biology and Technology* 36, 253–263
- Oraman N (1947). Ankara armudu üzerinde morfolojik, fizyolojik ve biyolojik araştırmalar. *Ankara Yüksek Ziraat Enstitüsü Dergisi*, 8(1): 1–18 (Ayrı basım).
- Özbek S (1947). Türkiye armut yetiştiriciliği ve önemli armut çeşitlerimiz. Yüksek Ziraat Enstitüsü Basımevi. Ankara 95p.
- Özbek S (1978). *Özel Meyvecilik*. Ankara Üniversitesi Basımevi. Ankara. 486p.
- Pekmezci M (1975). Bazı önemli armut ve elma çeşitlerinin solunum klimakterikleri ve soğukta muhafazaları üzerinde araştırmalar. Tarım ve Orman Bakanlığı Ziraat İşleri Genel Müdürlüğü Merkez İkmal Müdürlüğü Basımevi. Ankara. 80p.
- Saquet A A & Almeida D P F (2017). Ripening physiology and biochemistry of ‘Rocha’ pear affected by ethylene inhibition. *Postharvest Biology and Technology* 125, 161–167
- Trincherò G D; Sozzi G O; Covatta F & Frascina A A (2004). Inhibition of ethylene action by 1-methylcyclopropene extends postharvest life of ‘Bartlett’ pears. *Postharvest Biology and Technology* 32, 193–204
- TÜİK (2021). Turkish Statistical Institute. Agriculture. <https://biruni.tuik.gov.tr/medas/?kn=68&locale=tr> (Accessed date: 09/14/2021)
- Tuncel N & Köksal A İ (1986). Bazı elma ve armut çeşitlerinde derim öncesi, derim ve muhafaza sırasında meyvenin solunumu ile diğer bazı fizyolojik

- olaylar arasındaki ilişkiler. Ankara Üniversitesi Ziraat Fakültesi Yıllığı, 36(1): 1–10
- Ünver H (1994). Bazı sert ve yumuşak çekirdekli meyve türlerinin Ankara koşullarında etkili sıcaklık toplamı isteklerinin belirlenmesi. MSc Thesis. Ankara University, Graduate School of Natural and Applied Sciences, Department of Horticulture, Ankara, 124 p
- Villalobos-Acuna M G; Biasi V W; Mitcham E J & Holcroft D (2011a). Fruit temperature and ethylene module 1-MCP response in 'Bartlett' pears. *Postharvest Biology and Technology* 60, 17–23
- Villalobos-Acuna M G; Biasi V W; Mitcham E J & Holcroft D (2011b). Effect of maturity and cold storage on ethylene biosynthesis and ripening in 'Bartlett' pears treated after harvest with 1-MCP. *Postharvest Biology and Technology* 59, 1–9
- Watkins C B (2015). Advances in the use of 1-MCP, in: Wills R B H, Golding J B (Eds.), *Advances in Postharvest Fruit and Vegetables Technology*. Taylor and Francis Group, CRC Press, pp. 117–147, Boca Raton, Florida
- Westwood M N (1993). *Temperate-Zone Pomology*. Timber Press. Portland, Oregon. 523p





## CHAPTER 2

# MAJOR PHYSIOLOGICAL DISORDERS AND MANAGEMENT IN EUROPEAN PEAR (*PYRUS COMMUNIS* L.) DURING POSTHARVEST PERIOD

Emre AKKURT<sup>1</sup> & Nurdan TUNA GUNES<sup>2</sup>  
Yasemin EVRENOSOĞLU<sup>3</sup>

<sup>1</sup>Ankara University, Graduate School of Natural and  
Applied Sciences, Department of Horticulture, Ankara, Türkiye,  
e-mail: emre.akkurt13@gmail.com

 0000-0002-4451-3946

<sup>2</sup>(Prof. Dr.), Ankara University, Faculty of Agriculture,  
Department of Horticulture, Ankara, Türkiye,  
e-mail: tuna@agri.ankara.edu.tr

 0000-0002-8529-2211

<sup>3</sup>(Prof. Dr.), Eskişehir Osmangazi University,  
Faculty of Agriculture, Department of Horticulture, Türkiye,  
e-mail: yevrenosoglu@ogu.edu.tr

 0000-0002-0212-8492

### 1. Introduction

Pear is a species belonging to the Rosaceae family. Within this family, European pear cultivars are in *Pyrus communis* L. which is the main species native to Europe. While it is distributed in Europe, North America, South America, Africa and Australia, Western and SouthEast Europe, Türkiye and Spain are widely grown places for this species (Silva *et al.* 2014). While the most known cultivars are ‘Abbè Fèttèl’, ‘Anjou’, ‘Bartlett’, ‘Bosc,’ ‘Conference,’ ‘Doyenne de Comicè,’ ‘Rocha,’ ‘Packham’s Triumph’, there are

local cultivars based on the countries. ‘Deveci’, ‘Ankara’ and ‘Akça’ in Türkiye, ‘Shahmiveh’ in Iran are important local cultivars.

Pear fruit is one of two the most consumed and produced pome fruit species in the world. According to data of the Food and Agricultural Organization of United Nations for 2019, global pear production was ca. 3,919,075 tons. China (1.7 million ton), USA (661,340 ton), Argentina (595,427 ton) and Türkiye (530,723 ton) were the biggest producers. Global pear export quantity was ca. 2.7 million ton, export value was ca. 5.5 billion US \$. In this respect, China (export quantity 470,164 ton, export values 573,145 thousands US \$) was the first and followed by Netherlands, Belgium and Argentina. Global import quantity was 2.5 million ton, import value was 2,555,500 thousands ton. Indonesia, Brasil and Belarus were the main pear importers (FAO 2021).

In pear fruit, water content is 82-85%, soluble solids content 14.63-19.5%, sugars 9-11%. pH range of pulp and titratable acidity are 2.10-8.12, 0.154-0.462% malic acid depending on the cultivars, respectively (Bell 1991). European pears provide higher calories and sugar content, malic and citric acids are dominant organic acids. In ‘Radana’ pear fruit, fructose is the major sugar in pulp, seeds and peel (Kolniak-Ostek 2016). Glucose, fructose, and sucrose in fruit are produced from sorbitol which is transferred from leaves to the fruit, and the composition of these four sugars plays a key role in sweetness of pear fruits. Phenolic acids and their derivatives are widely distributed in pear fruit (Li *et al.* 2014). Moreover, pear leaves and seed are rich in phytochemicals and they may be selected as a potential sources (Kolniak-Ostek 2016). Pear fruit can be consumed widely due to not only its unique aroma and taste but also its availability on the shelf for a long time.

The European pear cultivars show a climacteric respiratory pattern during ripening period. Ethylene is a major factor contributing to yellowing, softening, and senescence behaviours (Villalobos-Acuña & Mitcham 2008). Most European pear cultivars requires a certain period of cold exposure to trigger ethylene biosynthesis for ripening which is genetically controlled (Hewitt *et al.* 2020). This period at 0°C can vary between 15 days (‘Bartlett’) and 90 day (‘Passa Crassane’) but ‘Bosc’ cultivar needs ethylene for ripening instead of a chilling period (Sugar & Einhorn 2011). European pears are classified as summer, autumn and winter cultivars in respect of their ripening seasons, differences in pear development, storability and ethylene response (Wang 2016). Winter cultivars can be stored more than four months under cold storage conditions. Other storage technologies such as controlled atmosphere (CA) storage and modified atmosphere packaging (MAP) help

to prolong of storage period upto nine months for some cultivars. However, some of winter cultivars show certain physiological disorders causing important amount of food loss after long-term storage period. Many reasons such as inappropriate pre-harvest ecological conditions and management techniques, harvesting time, insufficient cooling, storage and handling processes can impact the rate and severity physiological disorders. The goal of this chapter is to summarize common physiological disorders in pear fruit encountered during postharvest storage period and to review necessary precautions to cope with.

## 2. Superficial Scald

Superficial scald is caused by necrosis of hypodermal cortical tissue in the peel. Brown patches are visible on the peel. At low storage temperature, disorder can not be visual but after transferring the fruit to the room temperature, it becomes more visual after 24 hours or a couple of days. The appearance of fruit is severely affected and resulted with decreasing market value of the fruit. Some cultivars such as ‘Anjou’, ‘Packham’s Triumph’, ‘Abbè Fetel’, ‘Spadona’, ‘Bartlett’ and ‘Blanquilla’, are sensitive (Fig. 1). Superficial scald is different from the senescent scald. In the second one, additionally fruit appearance, fruit taste negatively changes, as well.



Figure 1. The appearance of superficial scald in ‘Bartlett’ fruit

According to the Wang (2016), development of disorder begins with damaging of peel cells by conjugated trienols (CTols) which are oxidation products of  $\alpha$ -farnesene, a sesquiterpene compound. CTols are toxic for cell membranes and cause browning of the fruit peel via polyphenol oxidase (PPO) activity. This mechanism has been accepted by Whitaker *et al.* (2009) in ‘Bartlett’, Busatto *et al.* (2021) in ‘Blanquilla’ and ‘Conference’, Giné-Bordonaba *et al.* (2020) in ‘Blanquilla’ cultivars. Ethylene, which is an important plant growth regulator in pear ripening process, can affect the accumulation of  $\alpha$ -farnesene in the peel

(Giné-Bordonaba *et al.* 2020; Busatto *et al.* 2021; Lindo-García *et al.*, 2021). In ‘Anjou’ pear fruit, Zhao *et al.* (2016) reported that the antioxidant systems in the peel had a functional role on scald development by affecting the oxidation of  $\alpha$ -farnesen to CTols. Larrigaudière *et al.* (2016) determined higher ascorbic acid content for higher resistance in ‘Packham Triumph’ cultivar. Ascorbic acid has a rule on preventing scald by inhibiting PPO activity.

Disorder’s severity depends on late harvest and over ripening, higher nitrogen fertilization and higher temperature regime during fruit growth and development season, lower fruit calcium content, long period between harvest and storage, non-optimum storage temperature regime (Chen 2016; Caracciolo *et al.* 2020). However, ecological factors such as higher temperatures occurring during fruit growth and development in some years can prevent the positive effects of aforementioned precautions. 1-methylcyclopropane (1-MCP) as an inhibitor on ethylene perception and action can be used for maintaining quality after harvest in many climacteric fruit species (Sisler & Serek 1997). Long-term storage period stimulates ethylene production in pear fruit. According to Giné-Bordonaba *et al.* (2020), 1-MCP treatment after harvest can control superficial scald but regaining of the ripening capacity after long-term storage can negatively effect. In ‘Abate Fetel’ pear fruit, 1-MCP treatment strongly reduces ethylene production stored at  $-0.5^{\circ}\text{C}$ , inhibits softening, yellowing and the development of superficial scald (Vanoli *et al.* 2016). Besides 1, 2-dihydro-6-ethoxy-2, 2, 4-trimethyl-quinoline (ethoxyquin) and diphenylamine treatments, CA conditions at 1.5-2% oxygen ( $\text{O}_2$ ) helps to decrease the severity. In ‘Doyenne du Comice’ pear fruit, CA storage completely prevents the scald symptoms (Ma & Chen 2003). In recent years, consumer awareness on residues in fruit and vegetables, mostly prevent using chemicals to control of such kind of disorders. Du *et al.* (2021), suggested that low (1%)  $\text{O}_2$  concentrations could help to prevent superficial scald instead of chemical control. Lower scald rates occurred in  $\text{CaCl}_2$  treated and modified atmosphere packed fruit than controls.

### 3. Senescent Scald

Senescent scald is different from superficial scald and the main reason is the senescent and over ripening process. ‘Bartlett’, ‘Bosc’, ‘Comice’ are the sensitive cultivars that have faster ripening ability during lower storage temperatures. Disorder begins with small brown blemishes on the peel and brown area spread out on the peel and inside the flesh by the progressing of ripening stage. It can be observed in cold storage rooms or during shelf life

periods after a certain cold storage periods. Unfavorable aroma and taste develops, peel becomes thin but flesh can be still hard. The fruit can not regain its ripening capability after cold storage. All storage technologies preventing the ripening and senescence decreases senescence scald. These are CA and MA storage, treatments with some plant growth regulators such as 1-MCP, AVG, harvest at optimum maturity, cooling as soon as possible after harvest (Wang & Sugar 2015; Wang *et al.* 2016). In ‘Bosc’ pear fruit, 1-MCP treatments inhibit ethylene production and respiration rate, retard the degradation of chlorophyll and titratable acidity, and extend storage quality, decreased decay rates depending on ripening and senescence; but inhibited ripening capacity (Xie *et al.* 2017). ‘Ankara’ pear in an important local Turkish cultivar and late harvest triggers senescent scald in this cultivar (Fig. 2). Its storage life can be extended up to six months but 1-MCP treatments keep fruit quality and inhibits senescent disorders such as scald during up to seven months at 0°C (Bakoğlu & Gunes 2020).



Figure 2. Senescent scald in late harvested ‘Ankara’ pear cultivars after 7 months at 0°C + 7 days at 20°C

#### 4. Watercore

In this disorder, a watery translucent area occurs around the main vascular bundle in the fruit. Watercore develops in that watery area because intracellular spaces are full of water instead of air. Firstly, watercore development begins around core tissues and primary vascular bundles but in case of increase in severity, it can be flowed from the outside of the fruit. Uysal & Akçay (2020) monitored watercore development in on-tree ‘Deveci’ pear fruit and the external symptoms can occur in this cultivar (Fig. 3). Fruit having watercore are sensitive to internal browning symptoms and abnormal taste development.



Figure 3. Fruits with water-core disorder in ‘Deveci’ pear (left), internal appearance of fruit with and without watercore (right) (Uysal & Akçay 2020, <https://dergipark.org.tr/tr/download/article-file/1570700>)

The reason of watercore development can be higher photosynthesis rate which causes higher production of assimilate and carbohydrate and higher sugar accumulation in fruit. Tissues having watercore included higher sorbitol and sucrose. The accumulation of sugar derivatives in the cell resulted with degradation of cell wall and often causes leakage of cytoplasm into intercellular spaces. Generally higher leaf/fruit rate, gibberellic acid treatments causes watercore. In some pear cultivars, watercore associated with sunburn. Uysal & Akçay (2020) studied in the Turkish famous cultivar ‘Deveci’ and determined lower calcium, magnesium, manganese, and boron values in fruit tissues show watercore, in the contrast, healthy tissues had higher amounts of these minerals. The results of this study shows that watercore problem can be closely related with the calcium, magnesium, manganese, and boron content of the fruit. In the same study, the researchers could not obtain any relationship between watercore severity and phosphorus, potassium, iron, zinc and copper content of fruit.

## 5. Cork Spot

Fruit having cork spot develops irregular bumpy areas on the generally yellowish skin. When these fruit are peeled or cut, brown blemishes in different largeness and at different flesh depths are visual. Generally, the fruit show no external symptoms. Cork spot is common in ‘Anjou’, ‘Packham’s Triumph’, ‘Bartlett’ and ‘Bosc’ cultivars. Although it develops normally on-tree, it can occur during cold storage period and at that time it is called as “storage spot” and ‘Anjou’ is the most sensitive cultivar to cork spot (Fig. 4).





Figure 4. Cork spot in ‘Anjou’ pear fruit.

(<https://pnwhandbooks.org/plantdisease/host-disease/pear-pyrus-spp-cork-spot>)

Cork spot generally can be detected in the orchard or in packaging houses and in some cases, it is possible to meet with fruit having cork spot on the shelf. For ‘Anjou’ pear fruit, the rate of cork spot was directly related with fruit calcium content and the lower calcium content of the fruit the higher cork spot rate. Hot and dry weather conditions during fruit and development period often stimulates cork spot formation by causing water stress on the tree (Richardson & Lombard 1979). Similarly, cork spot rate was higher in trees having lower yield and lower nitrogen fertilization (Raese 1989). Fallahi & Larsen (1981) mentioned the effect of rootstock on cork spot development. Richardson & Lombard (1979) reported ‘Anjou,’ ‘Packham’s Triumph,’ ‘Bartlett,’ and ‘Bosc’ as sensitive cultivars. The position of the ‘Anjou’ pear fruit on the tree can determines the level of cork spot and fruits located on the upper side of the canopy can shows higher level of cork spot than fruits located base side of the canopy. The reason of these differences is lower nitrogen/calcium rate in the fruit located upper side of the canopy. Similarly, Vaz & Richardson (1985) putforward that fruit with higher calcium content lower cork spot rate after long-term storage period. Calcium sprays during earlier fruit growth and development period enables to lower cork spot rate in fruit. Calcium sprays in ‘Rocha’ pear increases fruit calcium content at a rate of 12.2-38.3% (Pessoa *et al.* 2021). Therefore, pre-harvest cultural applications, which results with increase in calcium uptake of the tree, can cause decrease in cork spot rate after harvest in pear fruit. The applications during fruit growth and development causing decrease in carbohydrate competition among fruit, shoots and leaves helped to decrease cork spot rate in fruit. Raese (1989) grouped these applications as application of right pruning techniques, especially summer pruning, limiting nitrogen and potassium fertilization, right rootstock selection and usage, using plant growth regulators.

## 6. Black Speck

Black speck is manifested by the uneven or irregular distribution of brown and dark brown spots in different size on the fruit peel and it can be a significant problem after long-term CA storage in 'Anjou' pears. Chen (2016) mentioned that core breakdown could be followed with black speck. Lower O<sub>2</sub> rate as 1% during CA storage can induce black speck and for this reason, some protocols are arranged, O<sub>2</sub> > 1% during CA storage of pear fruit (Chen & Varga 1997)

## 7. Cortical Browning

Cortical browning is known as flesh browning, internal browning or brown heart. There can be a lot of different reason such as low temperature during storage or on-tree maturity season, unsuitable atmosphere conditions during CA storage etc. This disorder can take into consideration as mostly stress-induced disorder. The mechanism is oxidation of phenolic compounds to *o*-Quinone's by PPO activity and cellular degradation is necessary before the browning but, according to Larrigaudière *et al.* (1998), the content of phenolic compounds and PPO activity level are not the limiting factors for the severity of disorder. Cortical browning can occur after CA storage conditions because of hypoxia caused by higher CO<sub>2</sub> levels (Franck *et al.* 2007). Additionally, it is a kind of CO<sub>2</sub> injury and causes brown color and dry gaps at different sizes in cortical area but, the external appearance of the fruit is sound and healthy. The size of the gaps mostly depends on the CO<sub>2</sub> stress level. Under unsuitable CA atmosphere conditions some cultivars such as 'Conference', 'Blanquilla', 'Rocha', 'Passe Crassane', 'Williams Bon Chretien', 'Bartlett' and 'Comice' tend to develop cortical browning symptoms (Franck *et al.* 2007). In 'Conference' and 'Bartlett' pear cultivars, some studies showed that excessive low O<sub>2</sub> and high CO<sub>2</sub> concentrations increased oxidation reactions by resulting with alcohol and acetaldehyde, besides some reactive oxygen species that caused oxidative decomposition in the cell membrane (Larrigaudière *et al.* 2001). Wang & Sugar (2013 a,b) in 'Conference', 'Bartlett' and 'Comice' pear cultivars, determined that ascorbic acid had an important function to prevent browning. However, in 'Doyenne du Comice' cultivar, CA storage prevented cortex browning after four months (Ma & Chen 2003). In 'Rocha' pear fruit, dynamic controlled atmosphere storage with chlorophyll sensor can be an effective way to decrease flesh browning (Deuchande *et al.* 2016a) It seems that some growth regulators such as 1-MCP and AVG help to prevent browning by inhibiting ascorbic acid loss during storage period. Vanoli *et al.* (2016) reported that 1-MCP treatment strongly reduced ethylene production and internal breakdown and browning in 'Abbe Fettel' pear fruit. Deuchande *et al.* (2016b)



showed the when atmosphere conditions are the same with required conditions by the cultivar ascorbic acid degradation increased and this caused occurring of flesh browning. Some pre-harvest factors such as colder growing seasons become the fruit more sensitive to cortical browning (Franck *et al.* 2007). Xuan *et al.* (2005) mentioned that pre-harvest calcium and boron treatments inhibited cortical browning in ‘Conference’ cultivar. Moreover, crop load (Franck *et al.* 2007), delayed harvest period can effect tolerance of fruit. For the postharvest period, storage temperature and atmosphere composition in CA storage technology are the main factors affecting cortical browning. The increase of ethylene levels in storage room air helps to increase in cortical browning rate and severity (Bower *et al.* 2003). The effect of 1-MCP for preventing cortical browning depends on the cultivars (Hendges *et al.* 2015). Salicylic acid treatment can affect browning symptoms. Salicylic acid application of ‘Patharnakh’ pear fruit alleviates the rate of weight loss and respiration rate, decreases in decay percentage and browning incidence (Adhikary *et al.* 2021). The effect of different packaging materials on browning vary based on the cultivars. Corrugated fiberboard boxes can completely prevent the browning in ‘Punjab Beauty’ cultivar (Kaur *et al.* 2013).

In recent years, consumer preference has tended to non-chemical treatments and, heat treatments offer an advantage as non-chemical applications for the consumers. Postharvest heat treatments appear to inhibit fungal decay, improve insect disinfections, disease and nutritional control during storage period (Lurie 1998; Fallik & Ilić 2021). By slowing down ripening, postharvest heat treatments can help to manage browning symptoms. Gunes *et al.* (2006) treated with ‘Akça’ pear fruit, an earlier Turkish local cultivar, with heat air at 38°C for 24, 48 and 72 hours and then the researcher kept the fruit seven days at 20°C after a month at 0°C. Heat treatment for 48 and 72 h completely prevented cortex browning at the end of shelf life period (Fig. 5).



Figure 5. The appearance of heat treated ‘Akça’ pear fruit after 1 month 0°C + 7 days at 20°C

## 8. Core Breakdown

Core breakdown is also known as senescent browning is a result of senescence and increased by high ethylene production triggered by low temperature during storage (Wang & Sugar 2015). It can be seen during storage as well as marketing and shelf life period. ‘Bartlett’, ‘Bosc’, ‘Comice’ are susceptible cultivars and fast ripening develops in these cultivars. Larrigaudière *et al.* (2004) reported that these cultivars showed increase in CO<sub>2</sub>, ethanol, and acetaldehyde in the tissues around the core area and core breakdown is negatively correlated with alcohol dehydrogenase (ADH) activity. Therefore, the affected tissues have a disagreeable odor and taste. Disorder begins watery, soft and brown in core region tissues and later extends the whole tissues of fruit and these tissues become black with breakdown. Fruit taste is unfavorably damaged. Core breakdown can be a problem in CA if the CO<sub>2</sub> exceeds 1.0%. Low O<sub>2</sub> (<1.5%) CA is suitable for ‘Concorde’ pears (Drake *et al.* 2004).

All precautions to prevent fruit ripening and senescence will help to decrease the rate and severity of core breakdown in pear fruit. Some of them are optimum CA conditions for each cultivar, stable storage temperature, and harvest at optimum maturity. Additionally, application of plant growth regulators at pre- and postharvest period to inhibit ethylene production and action could help to decrease in disorder rate and severity. Aminoethoxyvinylglycine (AVG) and 1-MCP was reported to let to disorder control during storage period by inhibiting ripening and senescence in pear fruit (Villalobos-Acuña *et al.* 2011; Wang & Sugar 2015).

## 9. Brown Core

Brown core known as pithy brown core, is a problem especially for ‘Anjou’ and ‘Bosc’ cultivars under CA storage conditions and it is the result of CO<sub>2</sub> injury, lower O<sub>2</sub> condition has a stimulating effect on this disorder. According to Chen (2016), delaying of harvest and cooling after harvest, higher storage temperatures, and long CA storage can increase the incidence. Physiological mechanism of this disorder is inhibition of succinic dehydrogenase activity by high CO<sub>2</sub>, degeneration in Krebs cycle, accumulation of ethanol and acetaldehyde (Mattheis *et al.* 2013). In the last stage, membrane lipid peroxidation results with browning reactions (Wang *et al.* 2016). The first symptoms are visual entire of carpels and then cortex tissues around the carpels turn to brown color with dry appearance. Chen (2016) inhibited brown core in ‘Anjou’ cultivar by 0.15 µL L<sup>-1</sup> 1-MCP treatment and suggested CO<sub>2</sub> concentrations lower than 1.5%.

## 10. Weight Loss and Shriveling

Shriveling occurs after a water loss at 2-3% and seriously affects the appearance of fruit by causing decrease in marketability. Pears harvested at the immature or physiological maturity stage were more sensitive to shriveling during storage period. This disorder directly related with relative humidity and temperature of a storage room in which the fruit are stored. Actually, the basis water loss from the pear fruit is difference between vapor pressure of the fruit and vapor pressure of the air surrounding the fruit. The bigger difference the faster and the higher water loss from the fruit. However, the peel structure and characteristics of the fruit are other points. As structurally, the pear fruit has lenticels on the surface and they generally regarded as small doors open to outside, surrounding air. Water loss occurs via lenticels and this phenomenon is a kind of transpiration generally called as lenticular transpiration. Water loss means weight loss can be a huge product loss after long-term storage period. It can be parallel with the lenticel numbers per unit area, and additionally, wax amount and wax shape on the skin, cuticle thickness and fruit size are the other factors affecting water loss and indirectly shriveling. Small fruit tend to more water loss and shriveling earlier than medium or large size fruit. Fruit size Generally, CA and MA storage technology directly inhibits it while regular air storage can increase the severity if proper storage temperature under proper relative humidity conditions is not applied. Conditions, which the fruit meet during marketing or shelf life period, effects the shriveling rate in pear fruit, as well. In order to prevent or decrease water loss, harvesting at the optimum maturity stage, creating at least 90% relative humidity conditions and applying optimum storage temperature in storage rooms, fast cooling after harvest are the critical points. Different packaging materials, film-coating treatments investigated in recent years have given promising results. Coating of 'Le Conte' pear fruit by Arabic gum or essential oils decreased the decays resulted from physiological disorders and weight loss. CA storage counteracts the effect of higher storage temperature on weight loss in 'Rocha' pear. The reduction in weight loss under CA is likely due to the reduction in water loss (Gago *et al.* 2013).

## 11. Oxygen and Carbondioxide Injury

Gas exchange status of pear fruit is one of the factors affecting the post-harvest life. The exchange of O<sub>2</sub> and CO<sub>2</sub> gases and their relationships significantly affect the metabolic processes of the fruit. Storage conditions can directly effect gas exchange in pear fruit. CA storage conditions are widely used for pear fruit

and disorders during CA storage may be due to low  $O_2$ . Low  $O_2$  and high  $CO_2$  results in tissue damage because of fermentation which finally leads to cell death (Franck *et al.* 2007).

In a model revealed by Delele *et al.* (2019) in ‘Comice’ pear cultivar, fruit size affected  $O_2$  and  $CO_2$  concentrations inside the fruit. Larger fruits had relatively lower  $O_2$  and higher  $CO_2$  at the fruit mass centres. Storage with very low  $O_2$  with an average respiration quotient equals to 3.04 in the surrounding air but 5.08 in the cells, the cellular  $O_2$  concentration of the fruits was lower than the critical concentration for ATP imbalance (0.043 kPa), so increase in susceptibility to hypoxia related disorders occur. In another study, significant impact of the fruit age on gas exchange rate was observed. As for model of Ho *et al.* (2010), ripening of the fruit increased the risk of physiological disorders, since increased respiration resulted in anoxia in the fruit centre even under typical storage conditions. In ‘Santa Maria’ pear fruit, hypoxic conditions (2 weeks under 99.5% nitrogen) can trigger core browning and scald development after a shelf life period for two weeks at 20°C at beginning of the cold storage period (Tuna Gunes unpublished data) (Fig. 6).



Figure 6. Early stages of core browning (left) and superficial scald (right) in ‘Santa Maria’ pear fruit the end of the shelf life of two weeks at 20°C after hypoxia conditions.

As a result of the studies on the measurement of gas exchange in fruit, it was revealed that since respiration in pears is an ongoing process during the storage period, the decreased amount of  $O_2$  during storage may cause physiological disorders (Ho *et al.* 2010). In order to prevent the damage of low  $O_2$  conditions during storage, coating applications seems to be applicable. Within this context, alginate-based nanoemulsions enriched with lemongrass essential oil or citral coatings in ‘Rocha’ pear (Gago *et al.* 2020), chitosan–beeswax/pollen grains coatings in ‘Le Conte’ pear (Sultan *et al.* 2021), edible coatings based on whey

protein isolate and essential oils (lemon and lemongrass) in fresh-cut pears (Galus *et al.* 2021), and chitosan coatings alone (1.0 and 2.0 %) or combined with 2.0 mM salicylic acid in ‘Punjab Beauty’ pear (Sinha *et al.* 2021) can successfully help to decrease in physiological disorders.

## 12. Freezing Injury

Freezing injury can occur when fruit are stored under freezing temperature (-1.1°C). It causes a wet appearance earlier on the peel. However, irregular temperature regime stimulates freezing injury symptoms. Fruit with low soluble solids content are more susceptible.

## 13. Conclusions

Our research describes the production quantities, fruit quality values, the introduction of postharvest physiological disorders, the causes of damage and their control in European pear (*Pyrus communis* L.) cultivars. Many European pear cultivars are susceptible to post-harvest physiological disorders and the results of scientific studies suggest a number of pre and postharvest treatments for disorder control. However, not only cultivar susceptibility but also fruit physiological stage, harvest time and maturity are important markers to cope with the disorders in order to fight food loss. In order to fully understand and eliminate postharvest physiological disorders, susceptibility of new genetic materials should be questioned in breeding studies. Although there are many studies on the effect of different factors in physiological disorders, there are few studies explaining the crosstalk between storage conditions and different ecological conditions during fruit growth and development in respect of susceptibility to disorders. Moreover, in recent years, global climate change can effect fruit yield and quality but still the effect of global climate change on physiological disorders in pear fruit is unclear. The future research can help to take into consideration the precautions.

## References

- Adhikary T; Gill P S; Jawandha S K; Bhardwaj R D & Anurag R K (2021). Browning and quality management of pear fruit by salicylic acid treatment during low temperature storage. *Journal of the Science of Food and Agriculture* 101(3): 853-862.
- Bakoğlu N & Tuna Gunes N (2020) The effect of 1-MCP concentration on skin and flesh color polyphenol oxidase activity during cold storage and shelf

- life periods in 'Ankara' pear (*Pyrus communis* L.). *Acta Horticulturae* 1275, 221-227.
- Bell R L (1991). Pears (*Pyrus*), *Acta Horticulturae* 290, 657-700.
- Bower J H; Biasi W V & Mitcham E J (2003). Effect of ethylene in the storage environment on quality of 'Bartlett' pears. *Postharvest Biology and Technology* 28(3): 371-379.
- Busatto N; Giné-Bordonaba J; Larrigaudière C; Lindo-Garcia V; Farneti B; Biasioli F; Vrhovsek U & Costa F (2021). Molecular and biochemical differences underlying the efficacy of lovastatin in preventing the onset of superficial scald in a susceptible and resistant *Pyrus communis* L. cultivar, *Postharvest Biology and Technology* 173, 111435.
- Caracciolo G; Magri A; Petriccione M; Maltoni M L & Baruzzi G (2020). Influence of cold storage on pear physico-chemical traits and antioxidant systems in relation to superficial scald development. *Foods* 9, 1175.
- Chen P M & Varga D M (1997). Determination of optimum controlled atmosphere regimes for the control of physiological disorders of 'd'Anjou' pears after short-term, mid-term or long-term storage. pp. 85-90. In: E J Mitcham (ed.). *Proceedings of the Controlled Atmosphere Research Conference on Apples and Pears* vol. 2. University of California, Davis, California.
- Chen P M (2016). Pear. pp. 471-480. In: K C Gross; C Y Wang & M Saltveit (eds.). *The Commercial Storage of Fruits, Vegetables, and Florist and Nursery Crops*. USDA, *Ars, Agriculture Handbook* 66, Washington D.C.
- Delele M A; Bessemans N; Gruyters W; Rogge S; Janssen S; Verlinden B E; Smeets B; Ramon H; Verboven P & Nicolai B M (2019). Spatial distribution of gas concentrations and RQ in a controlled atmosphere storage container with pear fruit in very low oxygen conditions. *Postharvest Biology and Technology* 156, 110903.
- Deuchande T; Carvalho S M P; Guterres U; Fidalgo F; Isidoro N; Larrigaudière C & Vasconcelos M W (2016a). Dynamic controlled atmosphere for prevention of internal browning disorders in 'Rocha' pear. *LWT - Food Science and Technology* 65, 725e730.
- Deuchande T; Larrigaudière C; Gine-Bordonaba J; Carvalho S M P & Vasconcelos M W (2016b). Biochemical basis of CO<sub>2</sub>-related internal browning disorders in pears (*Pyrus communis* L. cv. Rocha) during long-term storage. *Journal of Agricultural and Food Chemistry* 64(21): 4336-4345.
- Drake S R; Mielke E A & Elfving D C (2004). Maturity and storage quality of 'Concorde' pears. *HortTechnology* 14(2): 250-256.



- Du Y; Wang W; Jia X; Wang Z; Tong W & Zhang X (2021). Effects of initial low oxygen treatments on superficial scald prevention and ethylene release in pear. *Acta Horticulturae Sinica* 48(1): 15-25.
- Fallahi E & Larsen F E (1981). Rootstock influences on 'Bartlett' and 'd'Anjou' pear fruit quality at harvest and after storage. *HortScience* 16: 650-651.
- Fallik E & Ilić Z (2021). The influence of physical treatments on phytochemical changes in fresh produce after storage and marketing. *Agronomy* 11, 788.
- FAO (2021). United Nations, Food and Agricultural Organization. Statistical databases. <http://www.fao.org/faostat/en/#data/QC>
- Franck C; Lammertyn J; Ho QT; Verboven P; Verlinden B & Nicolai B M (2007). Browning disorders in pear fruit. *Postharvest Biology and Technology* 43(1): 1-13.
- Gago C M L; Miguel M G; Cavaco A M; Almeida D P F & Antunes M D C (2013). Combined effect of temperature and controlled atmosphere on storage and shelf-life of 'Rocha' pear treated with 1-methylcyclopropene. *Food Science and Technology International* 21(2): 94-103.
- Gago C; Antão R; Dores C; Guerreiro A; Miguel M G; Faleiro M L; Figueiredo A C & Antunes M D (2020). The Effect of nanocoatings enriched with essential oils on 'Rocha' pear long storage. *Foods* 9, 240.
- Galus S; Mikus M; Ciużyńska A; Domian E; Kowalska J; Marzec A & Kowalska H (2021). The effect of whey protein-based edible coatings incorporated with lemon and lemongrass essential oils on the quality attributes of fresh-cut pears during storage. *Coatings* 11 (7): 745.
- Giné-Bordonaba J; Busatto N; Larrigaudière C; Lindo-García V; Echeverría G; Vrhovsek U; Farneti B; Biasioli F; De Quattro C; Rossato M; Delledonne M & Costa F (2020). Investigation of the transcriptomic and metabolic changes associated with superficial scald physiology impaired by lovastatin and 1-methylcyclopropene in pear fruit (cv. 'Blanquilla'). *Horticulture Research* 7, 49.
- Gunes N T; Aygun A & San B (2006) Postharvest heat treatments for enhanced fruit quality during storage of early ripening European pear. *European Journal of Horticultural Science* 71 (3): 135-142.
- Hendges M V; Steffens C A; Neuwald D A & Kitemann D (2015). 1-MCP treatment increases internal browning disorders in 'Alexander Lucas' pears stored under controlled atmosphere. *Acta Horticulturae* 1071, 511-517.
- Hewitt S L; Hendrickson C A & Dhingra A (2020). Evidence for the involvement of vernalization-related genes in the regulation of cold-induced ripening in 'd'Anjou' and 'Bartlett' pear fruit. *Scientific Reports* 10, 8478.



- Ho Q T; Verboven P; Verlinden B E & Nicolai B M (2010). A model for gas transport in pear fruit at multiple scales. *Journal of Experimental Botany* 61 (8): 2071-2081.
- Kaur K; Dhillon W S & Mahajan B V C (2013). Effect of different packaging materials and storage intervals on physical and biochemical characteristics of pear. *Journal of Food Science and Technology* 50(1):147-152.
- Kolniak-Ostek J (2016). Chemical composition and antioxidant capacity of different anatomical parts of pear (*Pyrus communis* L.). *Food Chemistry* 203, 491-497.
- Larrigaudière C; Lentheric I & Vendrell M (1998). Relationship between enzymatic browning and internal disorders in controlled-atmosphere stored pears. *Journal of the Science of Food and Agriculture* 78, 232-236.
- Larrigaudière C; Lentheric I; Pinto E & Vendrell M (2001). Short term effects of air and controlled atmosphere storage on antioxidant metabolism in 'Conference pears. *Journal of Plant Physiology* 158, 1015-1022.
- Larrigaudière C; Lentheric I; Puy J & Pinto E (2004). Biochemical characterization of core browning and brown heart disorders in pear by multivariate analysis. *Postharvest Biology and Technology* 31, 29-39.
- Larrigaudière C; Candan A P; Giné-Bordonaba J; Civello M & Calvo G (2016). Unravelling the physiological basis of superficial scald in pears based on cultivar differences. *Scientia Horticulturae* 213, 340-345.
- Li X; Wang T; Zhou B; Gao W; Cao J & Huang L (2014). Chemical composition and antioxidant and anti-inflammatory potential of peels and flesh from 10 different pear varieties (*Pyrus* spp.). *Food Chemistry* 152, 531-538.
- Lindo-García V; Giné-Bordonaba J; Vall-Llaura N; Duaigües E & Larrigaudière C (2021). Unravelling the cold-induced regulation of ethylene and  $\alpha$ -farnesene and its involvement with the development of scald-like disorders in different pear cultivars. *Postharvest Biology and Technology* 174, 111441.
- Lurie S (1998) Postharvest heat treatments. *Postharvest Biology and Technology* 14, 257-269.
- Ma S S & Chen P M (2003). Storage disorder and ripening behavior of 'Doyenne du Comice' pears in relation to storage conditions. *Postharvest Biology and Technology* 28: 281-294.
- Mattheis J P; Felicetti D & Rudell D R (2013). Pithy brown core in 'd'Anjou' pear (*Pyrus communis* L.) fruit developing during controlled atmosphere storage at  $pO_2$  determined by monitoring chlorophyll fluorescence. *Postharvest Biology and Technology* 86, 259-264.

- Pessoa C C; Coelho A R F; Marques A C; Luís I C; Daccak A; Silva M M; Ramalho J C; Simões M; Reboredo F H; Pessoa M F; Legoinha P; Campos P S; Pais I P & Lidon F C (2021). Increase of calcium in ‘Rocha’ pear (*Pyrus communis* L.) for development of functional foods. *Biology and Life Sciences Forum* 4, 6.
- Raese J T (1989). Physiological disorders and maladies of pear fruit. *Horticultural Reviews* 14, 357-411.
- Richardson D G & Lombard P B (1979). Cork spot of Anjou pear: Control by calcium sprays. *Communications in Soil Science and Plant Analysis* 10: 383-389.
- Silva G J; Souza T M; Barbieri R L & Costa de Oliveira A (2014). Origin, domestication, and dispersing of pear (*Pyrus* spp.). *Advances in Agriculture*, 2014, 541097.
- Sinha A; Gill P P S; Jawandha Preetinder Kaur S K & Grewal S K (2021). Chitosan-enriched salicylic acid coatings preserves antioxidant properties and alleviates internal browning of pear fruit under cold storage and supermarket conditions. *Postharvest Biology and Technology* 182, 111721.
- Sisler E C & Serek M (1997). Inhibitors of ethylene responses in plants at the receptor level: Recent developments. *Physiologia Plantarum* 100, 577-582.
- Sugar D & Einhorn T C (2011). Conditioning temperature and harvest maturity influence induction of ripening capacity in ‘d’Anjou’pear fruit. *Postharvest Biology and Technology* 60, 121-124.
- Sultan M; Hafez O M; Saleh M A & Youssef, A M (2021). Smart edible coating films based on chitosan and beeswax–pollen grains for the postharvest preservation of Le Conte pear. *RSC Advances* 11(16): 9572-9585.
- Uysal E & Akçay M (2020). The relationship between the mineral content of fruit and the watercore problem in Deveci pear. *Bahçe* 49 (2): 75-81.
- Vanoli M; Grassi M & Rizzolo A (2016). Ripening behavior and physiological disorders of ‘Abate Fetel’ pear treated at harvest with 1-MCP and stored at different temperatures and atmospheres. *Postharvest Biology and Technology* 111, 274-285.
- Vaz R L & Richardson D J (1985). Effect of calcium on respiration rate, ethylene production and occurrence of cork spot in d’Anjou pears (*Pyrus communis* L.). *Acta Horticulturae* 157, 227-236.
- Villalobos-Acuña M & Mitcham E J (2008). Ripening of European pears: The chilling dilemma. *Postharvest Biology and Technology* 49(2): 187-200.
- Villalobos-Acuña M G; Biasi W V; Flores S; Jiang C Z; Reid M S; Willits N H & Mitcham E J (2011). Effect of maturity and cold storage on ethylene

- biosynthesis and ripening in 'Bartlett' pears treated after harvest with 1-MCP. *Postharvest Biology and Technology* 59(1): 1-9.
- Wang Y & Sugar D (2013a). Internal browning disorder and fruit quality in modified atmosphere packaged 'Bartlett' pears during storage and transit. *Postharvest Biology and Technology* 83, 72-82.
- Wang Y & Sugar D (2013b). Ripening behavior and quality of modified atmosphere packed 'Doyenne du Comice' pears during cold storage and simulated transit. *Postharvest Biology and Technology* 81, 51-59.
- Wang Y & Sugar D (2015). 1-MCP efficacy in extending storage life of 'Bartlett' pears is affected by harvest maturity, production elevation, and holding temperature during treatment delay. *Postharvest Biology & Technology* 103, 1-8.
- Wang Y (2016). Storage temperature, controlled atmosphere, and 1-methylcyclopropene effects on  $\alpha$ -farnesene, conjugated trienols, and peroxidation in relation with superficial scald, pithy brown core, and fruit quality of d'Anjou' pears during long-term storage. *Journal of the American Society for Horticultural Science* 141, 177-185.
- Wang Y; Xie X & Song J (2016). Preharvest aminoethoxyvinylglycine spray efficacy in improving storability of 'Bartlett' pears is affected by application rate, timing, and fruit harvest maturity. *Postharvest Biology and Technology* 119, 69-76.
- Whitaker B D; Villalobos-Acuña M; Mitchamb E J & Mattheis J P (2009). Superficial scald susceptibility and  $\alpha$ -farnesene metabolism in 'Bartlett' pears grown in California and Washington. *Postharvest Biology and Technology* 53(1-2): 43-50.
- Xie X; Fang C & Wang Y (2017). Inhibition of Ethylene biosynthesis and perception by 1-Methylcyclopropene and its consequences on chlorophyll catabolism and storage quality of 'Bosc' pears. *Journal of the American Society for Horticultural Science* 142(2): 92-100.
- Xuan H; Streif A; Romheld V & Bangerth F (2005). Application of boron with calcium affects respiration and ATP/ADP ratio in 'Conference' pears during controlled atmosphere storage. *The Journal of Horticultural Science and Biotechnology* 80, 633-637.
- Zhao J; Xie X; Shen X & Wang Y (2016). Effect of sunlight-exposure on antioxidants and antioxidant enzyme activities in d'Anjou' pear in relation to superficial scald development. *Food Chemistry* 210, 18-25.

## CHAPTER 3

# PRUNING OF NON-FEATHERED NURSERY-PRODUCED APPLE, WALNUT AND SWEET CHERRY TREES IN THE FIRST AND SECOND LEAF: LESS KNOWN GENOTYPE-SPECIFIC APPROACHES

Ersin ATAY

(Assoc. Prof. Dr.), Burdur Mehmet Akif Ersoy University (MAKÜ),  
Food Agriculture and Livestock School, Department of Crop and Livestock  
Production, Horticulture Programme, Burdur, Türkiye,  
e-mail: ersinatay@mehmetakif.edu.tr

 0000-0003-0810-3779

### 1. Introduction

The push for fruit demand in parallel to increasing world population causes an increase in orchard acreage, especially in underdeveloped and developing countries. Every year, countless nursery-produced trees are planted around the world.

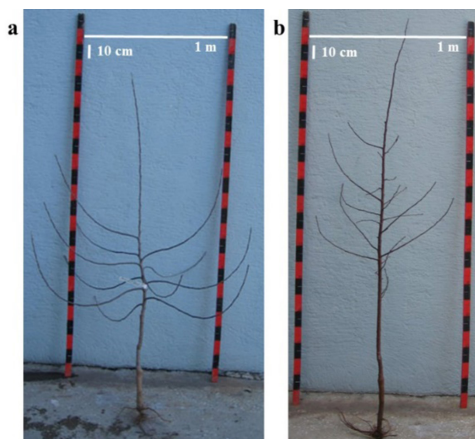
An orchard can be planted with ‘bench-grafts’, ‘sleeping eyes’ and ‘one-year-old bench-grafted’ nursery-produced tree types (Figure 1). The propagation methods of these tree types have been described in detail by Barritt (1992) and Garner (1988). A ‘bench-graft’ tree is comprised of rootstock that bench-grafted with a piece of dormant scion wood. The ‘sleeping-eyes’ are rootstocks budded in the late summer. The ‘one-year-old bench-grafted’ trees are bench-grafts grown one season in the nursery.

However, much of today’s orchards are planted with one-year-old and two-year-old nursery-produced trees (Kaplan & Baryla 2006, Lanar *et al.* 2019). A ‘one-year-old budded tree, also called as ‘maiden’ tree begins as the sleeping eye, and scion bud is allowed to grow one growing season in the nursery (Kaplan 2010). In two-year-old nursery tree production, the same procedures are followed in the first year as conducted in one-year-old bench-grafted trees (Atay & Koyuncu 2013a). In the following year, different approaches (e.g. knipboom

(Figure 2a) and fruitful tree (Figure 2b)) can be applied to shape the trees in the nursery (Atay & Koyuncu 2016). If a bud grafting in place is used instead of a bench-grafting in indoors, producing two-year-old trees could last three years (Kaplan & Baryla 2006, Lipecki *et al.* 2013).

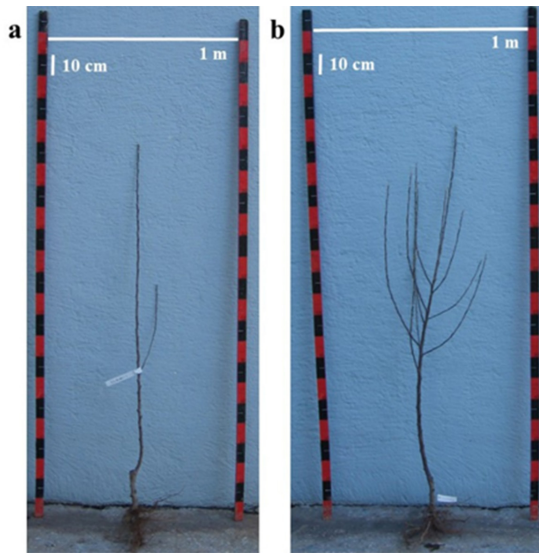


**Fig. 1.** From left to right: typical 'bench-grafted', 'sleeping-eyes' and 'one-year-old bench-grafted' apple nursery trees. Arrow indicates grafting point. Note that all of the tree types have a weak root development.



**Fig. 2.** Branched two-year-old apple nursery-produced trees exemplifying (a) knipboom (with one-year-old crown) and (b) fruitful (with two-year-old crown) types. Note that long laterals are in the basal (basitonic branching) and top (acrotonic branching) parts in knipboom and fruitful trees, respectively. Fruitful tree with shorter lateral branches tend to be longer than the knipboom tree. However, both types are thicker, longer and have more branches, compared to one-year-old trees.

Depending on the growing conditions and genetic inheritance, ‘one-year-old bench-grafted’ trees can sometimes produce sylleptic shoots (i.e. feathers - hereafter referred to as branches). ‘One-year-old budded’ trees are generally unbranched termed as one-year-old ‘whips’ (i.e. single stem trees) (Barden & Neilsen 2003) (Figure 3a) and sometimes branched (Radivojevic *et al.* 2015) (Figure 3b). Two-year-old trees, in general, produce more branches than one-year-old trees (Wertheim & Webster 2003). Regardless of how they are propagated, the nursery-produced trees with few branches can be considered as unbranched.



**Fig. 3.** (a) Unbranched and (b) branched one-year-old budded apple trees. Note that both tree types have a similar root development.

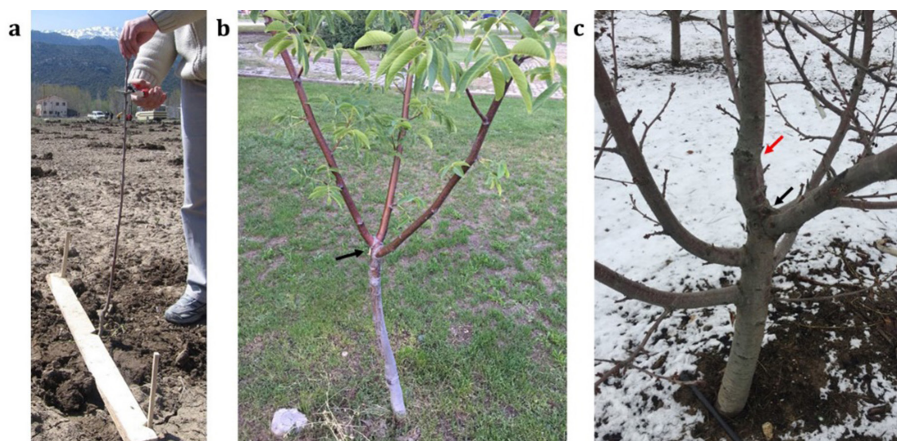
Well-branched nursery trees simplify subsequent pruning and enhance early yield (Gudarowska & Szewczuk 2004, Sosna 2016). For this reason, it has been a vast amount of research on lateral branching induction in the nursery (Williams & Billingsly 1970, Quinlan 1976, Basak *et al.* 1993, Jaumien *et al.* 1993, Hrotko *et al.* 1996, Sadowski *et al.* 2007, Gastol *et al.* 2012, Atay & Koyuncu 2013a, Atay & Koyuncu 2016, Lordan *et al.* 2017).

When orchards are planted with unbranched ‘one-year-old bench-grafted’ and ‘one-year-old budded’ nursery-produced trees, which are most likely represented nursery tree types when considering the all fruit tree species and cultivars, an unwanted tree shape may occur due to incorrect pruning approaches.

Most fruit growers perform heading cuts to unbranched trees at planting (Figure 4a) to improve branching (Quinlan & Tobutt 1990, Forshey *et al.* 1992,



Wertheim 2005). It wipes off potential fruiting laterals on the top of the leader (Atay & Koyuncu 2013a). The heading cuts may have been carried out earlier to reduce storage and transport costs of nursery-produced trees, which costs are pretty high-priced in some areas. This type of cuts generally results with the generation of hardened, competitive and narrow-angled proleptic branches generated only by a few numbers of buds in the vicinity of the cuts (Forshey *et al.* 1992, Hoying *et al.* 2001, Atay 2017a) (Figure 4b and Figure 4c). However, at the whole-tree level, pruning results in narrowed trunk diameter (i.e. weaker secondary growth), shorter trees (i.e. weaker primary growth) and weakened roots (Mika *et al.* 2003, Atay 2017b). This effect is the result of both the removal of tree reserves and the reduction of potential leaf area by pruning (Ferree & Schupp 2003), which delays precocity of fruiting and hit potential profit.



**Fig. 4.** Effects of heading in the orchard. (a) Heading an unbranched one-year-old tree at planting time. (b) Overly vigorous and upright proleptic branches with narrow crotches below the cut in response to heading in walnut at the end of the first leaf. (c) The response of a sweet cherry tree to heading in the long-term. The black arrow shows the heading cut point in the first leaf (at planting), and the red arrow shows the second heading cut point in the second leaf. Note that since there were few branches in the first leaf of a sweet cherry tree, a second heading (resulting with competitive lateral branches) cut made the following leaf, approximately 15 cm above the first leaf's cutting point.

It is vital to use proven pruning strategies to trees at planting and the following years to reach the optimum yield and tree shape targeted. Thus, structuring of young trees has a long-lasting effect over orchard life. An inappropriate pruning in young orchards can have quite adverse effects on long-term performance. When an orchard is planted with well-branched nursery-produced trees, the



need to induce branching is no longer valid because of the already established tree shape. When bench-grafts and sleeping-eyes are used at planting, knipboom and fruitful tree methods could be used to promote branching under orchard conditions. An enhance branching can be expected on knipboom and fruitful tree methods. Thus, orchard conditions provide more planting distances than nurseries, which confers more resources (e.g. light and nutrient) for growth. Indeed, it is possible to increase the number of branches by reducing the area in the shade (Wilson 2000).

One of the primary goals of a modern fruit grower is to obtain a high yield in the early years of planting and cover the infrastructure costs sooner (Forshey *et al.* 1992). Well-branched nursery-produced trees have a pivotal role in optimizing yield to achieve this goal (Vanderzande *et al.* 2016). Thus, the use of high-quality branched nursery-produced trees is particularly common in European countries where horticultural practices are relatively advanced.

However, commercially produced nursery trees often lack branches or they are unevenly branched, making initial training decisions hard and delaying early cropping (Mahdavi *et al.* 2020). Besides, the tree crop industry and nursery sector desire to decrease the production and transportation costs of nursery trees. The nursery companies will probably focus on the production of small-calliper, unbranched nursery trees. This study overviews not only already available information, but also recommends new and less known pruning approaches that are well-tested in the young orchards of Türkiye, one of the world's largest fruit-producing countries. Thus, according to the latest data (2019) of the Food and Agriculture Organization of the United Nations (FAO), Türkiye ranked first for sweet cherry, third for apple and fourth for walnut in terms of production quantity globally (FAO 2021). Besides economic, environmental and nutritional factors, less common nursery tree types (e.g. interstock trees and high grafted rootstocks) and other fruit species are beyond the scope of this book chapter.

## **2. Well-Tested Approaches for The Augmenting Branching of Unbranched Nursery Trees Under Orchard Conditions**

### ***2.1. Spur apple and walnut cultivars***

Our observations are based on spur type 'Red Delicious' apple cultivars onto M.26, MM.106 and MM.111 clonal rootstocks, and 'Şebin', 'Bilecik', 'Franquette' and 'Chandler' walnut cultivars on seedling rootstock (*Juglans regia*).

### 2.1.1. First leaf (Planting Year) in spur apple and walnut cultivars

As outlined above, most of the growers prefer head-pruning the main trunk at planting time. According to our observations, heading at planting in spur apple and walnut cultivars is to be an appropriate option (Atay & Koyuncu 2012, Atay 2017b). Thus, when they are not pruned, the buds at the top of the leader of these genotypes tend to develop into flower buds in the first leaf. It results in ‘spur bound’ indicated by weak vegetative development with numerous spur branches (Forshey *et al.* 1992).

In the training systems with a dominant central leader, a spur apple tree could be cut at 40 to 70 cm above the ground to strengthen and encourage vegetative growth in existing tree parts. In walnut, heading cut could be applied just above the third or fourth node (~50 cm) above ground. However, after heading, two different options (traditional and less common) may be considered.

In the “*traditional approach*”, the focus is on the proleptic branches below the cut point (Figure 5a). A new leader is chosen among these branches. The lateral branches competing with the leader are rubbed off when they reach a length of ~10 cm, and the remaining branches are left to grow (Atay & Koyuncu 2013a) (Figure 5b).



**Fig. 5.** Proleptic branching after heading. (a) Growing proleptic branches below the heading cut in the orchard. (b) A view from the tree at the end of the first leaf. Note that here we see quite enough branching due to (probably) using strong rootstock/scion combination (‘Starkrimson Delicious’/Seedling) and planting in autumn. In general, we see the opposite (i.e. insufficient branching) in such situations.

In the “*less known approach*”, as in the knipboom method, the bud at the top is kept as the new leader to grow, and remaining proleptic branches at the lower part are disbudded (Palmer *et al.* 2005, Atay & Koyuncu 2016) (Figure 6). It is crucial to keep safe this newly growing leader against wind damage. The leader can be tied to a bamboo cane to prevent breaking.



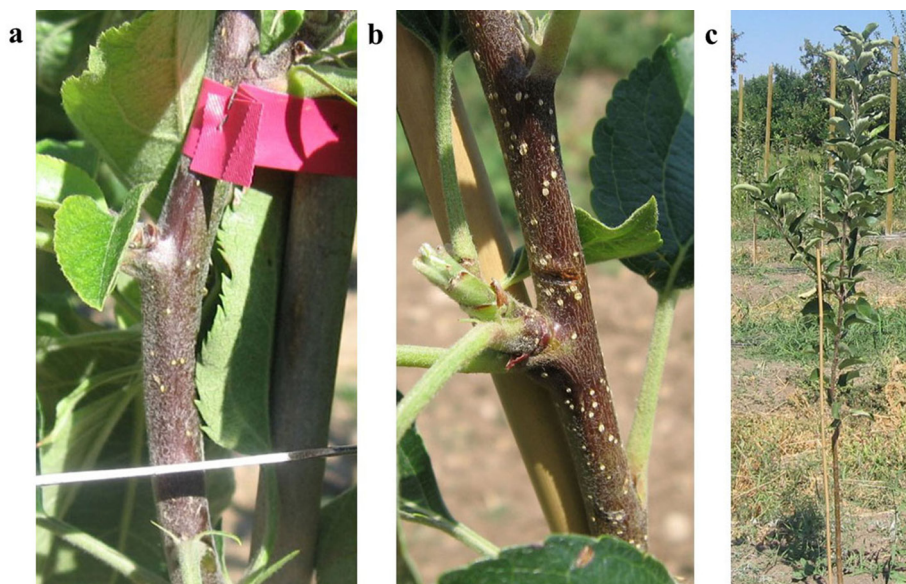
**Fig. 6.** The newly appointed leader in ‘Scarlet Spur’/MM.106 apple tree under orchard conditions. The remaining proleptic branches should be rubbed off to promote the fast growth rate of the new leader. Note that the newly growing leader is very sensitive to wind damage. Besides, some insect (e.g. aphids and cutworms) and disease outbreaks, especially powdery mildew (*Podosphaera leucotricha*), can harm the growth of the new leader severely.

Sylleptic branches can be expected to generate on this newly appointed leader. However, it is generally weak because of transplanting shock that decreases tree growth in the first leaf. Indeed, sylleptic branching occurs under fast growth rate conditions (Tworkoski & Miller 2007).

The first leaf could be considered as the invigoration period of trees. There is an equilibrium between the root and top of the trees (i.e. root: shoot balance) when they are in the nursery (Ferree & Schupp 2003). However, this equilibrium is disrupted, resulting in root: shoot ratio decrease, when trees are lifted from the nursery. This shock intensifies when the root system is not remained damp from lifting to delivery.

Notching on this stage (i.e. in the growing season) is not recommended because the branches in response to notching grow with too narrow-crotch angle and can compete with the leader (Figure 7). Shoot tip removal in summer can push the trees to encourage sylleptic laterals by interrupting apical dominance.

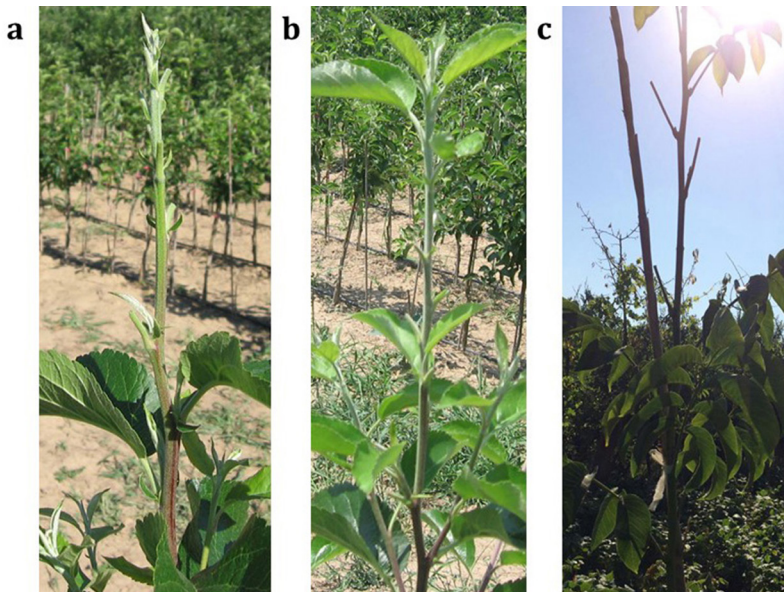
Apical dominance effect of shoot apex suppresses lateral bud outgrowth (Cline 1997). However, according to our own experience, shoot tip removal (just like notching) in summer leads to undesirable tree shape by resulting narrow-crochted laterals and bent leader. Therefore, there is no need to mention more on shoot tip removal here.



**Fig. 7.** Notching cut in summer and pushed sylleptic lateral branches in apple. (a) Notching of the leader applied in late June. (b) Induction of a competitor sylleptic branch in early July in response to notching. (c) A view from the narrow-angled and competitor sylleptic lateral branches in September.

Especially in walnut, the newly appointed leader, whose competitors have been removed, may show excessive vegetative growth. It leads to an augmentation in the length of the internode and prevents hardening. This kind of growth prevents targeted branching in the next season. Besides, the absence of hardening increases damage risk in the winter. In our experience, leaf removal (i.e. deblading) is one of the most useful methods to reduce leader vigour and increase hardening off (Figure 8). Indeed, leaf removing is a cultural practice that increases sylleptic branching by overcoming apical dominance in the fruit-tree nursery (Volz *et al.* 1994, Neri *et al.* 2004, Atay & Koyuncu 2013b). Different techniques such as leaf tearing-off (Jung & Lee 2008) and pinching (Lanar *et al.* 2019) that cut-off some part of the youngest leaf blades, while the growing shoot tip remains intact, are available. These techniques have similar effects to leaf removing to circumvent apical dominance.





**Fig. 8.** Leaf removal in order to shorten tree height and increase the hardening off. (a) Removing the immature apical leaflets on the leader of an apple nursery tree while the growing shoot tip stays untouched. The response of (b) apple and (c) walnut to leaf removal. Note that leaf removal can be done repeatedly with 7 to 10-day intervals depending on the vigour of the leader.

### *2.1.2. Second leaf in spur apple and walnut cultivars*

All long branches are renewed by bevel cuts (i.e. Dutch cuts), and any procedure is not applied on short laterals (i.e. spur and brindles) (Atay & Koyuncu 2013a). Proleptic branches are expected to generate in response to bevel cuts in the following growth season (Lauri & Lespinasse 2000). Spur apple cultivars, especially, react very positive to bevel cuts. Thus, natural extinction is very rare in these cultivars (Atay & Koyuncu 2012). The branch with the widest angle among the branches in response to renewal cut is to be chosen. It is a constructive way to get wide-angle branches for spur cultivars. Otherwise, the branching habit of spur cultivars is not suitable for spreading (explained below).

Indeed, both spur apple and walnut cultivars cannot show enough branching in the first leaf. The information mentioned here would be helpful to ensure homogeneity between trees at the end of the second leaf.

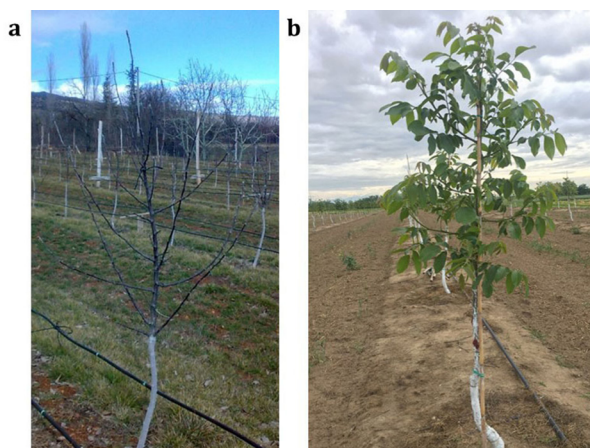
In addition to bevel cuts, a light heading cut (~15 cm) at the top of the leader is recommended in both species. This light cut can encourage vegetative growth moderately and prevent ‘spur bound’ at the top (Figure 9).



**Fig. 9.** A view of the leader of non-pruned 'Starkrimson Delicious'/MM.106 apple. In summer (left) and dormant season (right).

In walnut, no other pruning is to be needed afterwards.

In spur apples, additionally, nicking (or notching) and chemical branching agents at spring are to be recommended to impose bud-activation on the leader. Using nickings and chemical branching agents at spring were previously described elsewhere (Atay & Koyuncu 2013a). Briefly, in spring, with signs of green tips of buds, nicking cuts on the leader with 10 cm distances to 50-100 cm part (above ground) could be performed. Nicking is a small cut with a knife into the phloem without regard to the location relative to a bud location (Elfving & Visser 2007). Immediately after nicking cuts, a chemical branching agent at a high dosage (e.g. BA + GA<sub>4+7</sub> at 5000 mg L<sup>-1</sup> a.i.) can be applied by a small paintbrush (Atay & Koyuncu 2013a). Trees trained to this approach tend to grow with a dominant central leader with the non-competitor branches which are well-spaced and wide-angled (Figure 10).



**Fig. 10.** A view from the apple and walnut trees at the end of the second leaf. (a) 'Scarlet Spur Delicious'/MM.106 apple. (b) 'Chandler'/Seedling walnut.

When spreading limbs in spur apple cultivars, a large number of reaction branches can generate, especially in mature orchards (Figure 11). The above-described approach (i.e. less known approach) encouraging horizontal growth instead of vertical growth in spur apple cultivars. Thus, it avoids this reaction branch problem before it occurs.



**Fig. 11.** Growing reaction branches in response to limb spreading in mature ‘Redchief Delicious’/MM.111 apple.

## ***2.2. Non-spur apple and sweet cherry cultivars***

Our observations on apples were experienced on some non-spur with an average growth habit (namely ‘Golden Delicious’, ‘Gala’, ‘Granny Smith’) and semi-spur cultivars (namely ‘Braeburn’ and ‘Starkspur Golden Delicious’). The rootstock for non-spur cultivars was M.9 in the observations. Indeed, it has earned a reputation as an outstanding rootstock for vigorous non-spur cultivars (Barritt 1992). Semi-dwarfing two rootstocks, MM.106 and MM.111, were used for semi-spur cultivars in the observations. Sweet cherry experiences were based on the plant materials of ‘0900 Ziraat’ and ‘Regina’ cultivars on Mahaleb (*Prunus mahaleb*), MaxMa 14 and Mazzard (*Prunus avium*) rootstocks.

In our approach, whips should not be excessively large, and preferably have short internodes and be hardened off. Especially in genotypes grafted onto semi-dwarf or more vigorous rootstocks (such as MM.111, MaxMa14, Mahaleb and Mazzard). Moreover, especially sweet cherry whips should not be longer than 170 cm (preferably <150 cm). For this, it is recommended frequent leaf removal at the nurseries. The excessive growth of the leader of trees prevents the prolepsis in the second leaf, especially in sweet cherries.



Thus, sweet cherry trees are large by nature, strong with narrow crotch angles, and produce long shoots with few fruiting spurs, without being properly managed when young (Jacyna & Lipa 2008, Long *et al.* 2015), especially if a tree is vigorous. This type of branching habit frequently ends of ‘bare’ or ‘blind’ wood, which limits early production (Stebbins 1992, Palmer *et al.* 2005) and stimulates undesirable vigour.

### 2.2.1. First leaf in non-spur apple and sweet cherry cultivars

The leader in unbranched one-year-old non-spur apple and sweet cherry trees should be kept un-headed at planting. As stated above, all lateral branches on trees should be pruned by bevel cuts at planting.

In non-spur apple cultivars, nicking (or notching) cuts together with chemical branching agent applications at the green tip in spring (as described above as for spur cultivars) can trigger bud-activation on the leader (McArtney & Obermiller 2015). Especially in the cultivars on M.9 rootstock, in addition to proleptic branches, bourse shoots with sylleptic character generate (Figure 12). The bourse shoots are generated from axils of spur leaves beneath the flower cluster (Lauri *et al.* 2010, Atay 2017a).



**Fig. 12.** Bourse shoots generating from axils of spur leaves beneath the flower cluster on the one-year-old leader of ‘Golden Delicious’/M.9 apple.

Bourse shoots with sylleptic character do not occur on sweet cherries as in apples. However, a sweet cherry tree can have few proleptic branches. These branches generally cannot reach the number that can give the targeted tree shape. For this reason, sweet cherry trees without heading grow as a whip during the first leaf. Some alternative tree shaping techniques such

as heading (Moghadam & Zamanipour 2013), notching with (or without) branching agents (e.g. Promalin® (1.8% w/w BA + GA<sub>4+7</sub>) (Bennewitz *et al.* 2010), disbudding (Savini *et al.* 2007, Macit *et al.* 2017), twisting, scoring and sanding (Jacyna & Lipa 2008) at spring can be used. In my opinion, there is no need to apply such mechanical and chemical branching promoters in the first leaf in sweet cherry as they often show inconsistent results.

### 2.2.2. Second leaf in non-spur apple and sweet cherry cultivars

In non-spur apple cultivars, no heading cut is made in the leader as well as lateral branches. Since there is no heading at the first and second leaf in non-spur apple cultivars, the tree structuring is nearly completed at the end of the second leaf. Complementary pruning could be done according to the training system to be preferred. It is not within the scope of this book chapter.

In sweet cherries, nicking (Figure 13) accommodation with high dosage chemical branching agent at the green tip is recommended (Şahinoğlu *et al.* 2018). No other pruning is to be needed afterwards in sweet cherry to access to targeted tree shape (Figure 14).



**Fig. 13.** End-of-season effect of nicking cut applied in the green tip stage (Courtesy Ali Rıza Şahinoğlu).



**Fig. 14.** Close view of spirally distributed branches on ‘0900 Ziraat’/Mahaleb sweet cherry trees in the second leaf (Courtesy Ali Rıza Şahinoğlu).

Scoring, a circumferential knife cut through the phloem tissue around the trunk (Elfving & Visser 2007), may improve branching (Long 2005). I advise not to apply scoring as it injures the trunk bark, leading to pathogen attacks in sweet cherry. If the leader is cut off in any way before the second leaf, some methods such as leaf removal, water and nutrient limitation could be applied to suppress the vigour of sweet cherry trees. Then, the procedures described above can be applied with a one-year delay.

### 3. Epilogue

In order to be successful in orchard management, it is appropriate not to fight with the physiological and natural growth pattern of genotypes. Thus, branching of fruit trees is mostly genotype-dependent. In this respect, pruning in young orchards is still a crucial practice that requires a comprehensive approach. The shape the trees will have and pruning strategies should be decided before the orchard establishment. Questions to guide pruning should include: Should I cut the leader when planting? What kind of pruning strategy should I perform in the second leaf and beyond? The fruit growers are still in great confusion about heading the leader (i.e. main trunk) while planting or not. According to our experience, covering the past two decades, there are complementary solutions for trees headed while planting or not. This book chapter suggests some well-tested unconventional approaches on how to prune unbranched apple, sweet cherry and walnut nursery-produced trees during the first two years after planting to create the tree with a dominant central leader. When we think in this sense, approaches suggested

here could guide many fruit growers in an extensive area in the future and put a crucial benefit. There is little to no documentation on genotype-specific training and pruning approaches. The knowledge detailed here, which is restricted to apple, walnut and sweet cherry species, may be applied to other tree fruit orchards with some modifications. Fruit orchards should not only have the less known genotype-specific pruning approaches explained here, but the cultural practices such as irrigation, fertilization, pest control and weed control should be carried out thoroughly. It is also essential to not forget, orchard site must be convenient too.

### Acknowledgements

The author acknowledges Ali Rıza Şahinoğlu (TAGEM Apricot Research Institute) for providing original photos and A. Nilgün Atay (MAKÜ) for critically revising the paper.

### References

- Atay E & Koyuncu F (2012). Elmalarda dal mimarisi [Shoot architecture in apples]. *YYU J. Agr. Sci.* 22(3): 180-191 (TR)
- Atay E & Koyuncu F (2013a). A new approach for augmenting branching of nursery trees and its comparison with other methods. *Sci. Hortic.* 160: 345-350. DOI: 10.1016/j.scienta.2013.06.025
- Atay E & Koyuncu F (2013b). Elmalarda apikal dominansi ve apikal kontrol [Apical dominance and apical control in apples]. *SDU J. F. Agric.* 8(1): 99-110 (TR)
- Atay E & Koyuncu F (2016). Branch induction via prolepsis in apple nursery trees. *Acta Hort.* 1139: 439-444. DOI: 10.17660/ActaHortic.2016.1139.76
- Atay E (2017a). Cevizde (*Juglans regia* L.) ağaç mimarisi [Tree architecture in walnut (*Juglans regia* L.)]. *Bahçe* 46: 133-140 (TR)
- Atay E (2017b). A new insight into pruning strategy in the biennial cycle of fruiting: vegetative growth at shoot and whole-tree level, yield and fruit quality of apple. *Not. Bot. Horti. Agrobi.* 45(1): 232-237. DOI:10.15835/nbha45110527
- Barden J A & Neilsen G H (2003). Selecting the orchard site, site preparation and orchard planning and establishment. In: *Apples: Botany, Production and Uses*, Ferree D C & Warrington I J (eds.). CABI Publishing, Cambridge, 237-265
- Barritt B H (1992). Intensive orchard management. *Good Fruit Grower*, Yakima, Washington

- Basak A; Kolodziejczak P & Buban T (1993). Paturyl 10 WSC as a branching agent for young apple trees in nursery and orchards. *Acta Hort.* 329: 201-203. DOI: 10.17660/ActaHortic.1993.329.41
- Bennewitz E; Fredes C; Gutierrez L & Losak T (2010). Effect of the co-application of Promalin® at different bud phenological stages and notching at different distances on lateral branching of three sweet cherry cultivars (*Prunus Avium* L.) in central Chile. *Acta Univ. Agric. Silv. Mendel. Brun.* 58(2): 45-50
- Cline M G (1997). Concepts and Terminology of Apical Dominance. *Am. J. Bot.* 84: 1064-1069
- Elfving D C & Visser D B (2007). Improving the efficacy of cytokinin applications for stimulation of lateral branch development in young sweet cherry trees in the orchard. *HortScience* 42: 251-256. DOI: 10.21273/HORTSCI.42.2.251
- FAO (2021). FAOSTAT database collections. Food and Agriculture Organization of the United Nations, Rome. Available: <http://www.fao.org/faostat/en/#data/> [date of access: 12.07.2021]
- Ferree D C & Schupp J R (2003). Pruning and training physiology. In: *Apples: Botany, Production and Uses*, Ferree D C & Warrington I J (eds.). CABI Publishing, Cambridge, 319-344
- Forshey C G; Elfving D C & Stebbins R L (1992). Training and pruning apple and pear trees. Cornell Cooperation Extension, New York
- Garner R J (1988). *The Grafters' Handbook* (5<sup>th</sup> Edition). Sterling Publishing Co. Inc., New York
- Gąstol M; Domagała-Świątkiewicz I & Bijak M (2012). The effect of different bioregulators on lateral shoot formation in maiden apple trees. *Folia Hort.* 24(2): 147-152. DOI: 10.2478/v10245-012-0018-9
- Gudarowska E & Szewczuk A (2004). The influence of agro-technical methods used in the nursery on quality of planting material and precocity of bearing in young apple trees in the orchard. *J. Fruit Orn. Plant Res.* 12: 91-96
- Hoying S A; Robinson T L & Andersen R L (2001). Improving sweet cherry branching. *NYFQ* 9(1): 13-16
- Hrotko K; Buban K & Magyar L (1996). Improved feathering on one-year-old 'Idared' apple trees in the nursery. *Hortic. Sci.* 28(1-2): 29-34
- Jacyna T & Lipa T (2008). Induction of lateral shoots in unpruned leaders of young sweet cherry trees. *J. Fruit Orn. Plant Res.* 16: 65-73
- Jaumien Fr; Czarnecki B; Poniedziałek W & Mitrut T (1993). Very similar effects of a mixture of GA<sub>3</sub> and BA (6-Benzylaminopurine) and of GA<sub>4+7</sub> and BA on branching of some apple cultivars in nursery. *Acta Hort.* 329: 35-42. DOI: 10.17660/ActaHortic.1993.329.4

- Jung H W & Lee J Y (2008). Physical treatments influencing lateral shoot development in one-year-old Fuji/M.9 nursery apple trees. *Hortic. Environ. and Biote.* 49(5): 265-270
- Kaplan M & Baryla P (2006). The effect of growth regulators on the quality of two-year-old apple trees of 'Šampion' and 'Jonica' cultivars. *Acta Sci. Pol-Hortoru.* 5(1): 79-89
- Kaplan M (2010). Effect of growth regulators on the branching ability of maiden apple trees of the 'Šampion' and 'Jonica' cultivars. *Folia Hort.* 22(2): 3-7. DOI: 10.2478/fhort-2013-0152
- Lanar L; Mészáros M; Kyselová K; Sus J; Náměstek J; Běliková H & Čonka P (2019). Leaf pinching and phytohormones - two important components for the branching induction on sweet cherry. *Hortic. Sci.* 46: 171-179. DOI: 10.17221/12/2019-HORTSCI
- Lauri P E & Lespinasse J M (2000). The vertical axis and solax systems in France. *Acta Hort.* 513: 287-296. DOI: 10.17660/ActaHortic.1998.513.34
- Lauri P E; Kelner J J; Trottier C & Costes E (2010). Insights into secondary growth in perennial plants: its unequal spatial and temporal dynamics in the apple (*Malus domestica*) is driven by architectural position and fruit load. *Ann. Bot.* 102: 607-616. DOI: 10.1093/aob/mcq006
- Lipecki J; Jacyna T; Lipa T & Szot I (2013). The quality of apple nursery trees of knip-boom type as affected by the methods of propagation. *Acta Sci. Pol-Hortoru.* 12(6): 157-165
- Long L (2005). Sweet cherry training systems: Current practices in North America and Europe. *Compact Fruit Tree* 38: 20-23
- Long L; Lang G; Musacchi S & Whiting M (2015). Cherry Training Systems. A Pacific Northwest Extension Publication PNW 667 (April 2015)
- Lordan J; Robinson T L; Miranda Sazo M; Cowgill W; Black B L; Huffman L; Grigg-McGuffin K; Francescato P & McCartney S (2017). Use of plant growth regulators for feathering and flower suppression of apple nursery trees. *HortScience* 52(8): 1080-1091. DOI: 10.21273/HORTSCI11918-17
- Macit İ; Lang G A & Demirsoy H (2017). Bud management affects fruit wood, growth, and precocity of cherry trees. *Turk. J. Agric. For.* 41: 42-49. DOI:10.3906/tar-1610-27
- Mahdavi S; Fallahi E; Lang G & Fallahi B (2020). Gibberellic acid<sub>4+7</sub> and benzyladenine, cambium disconnection, nitrogen, and tip removal influence on branch induction in newly planted poorly feathered 'Fuji' apple trees. *Am. J. Plant Sci.* 11: 496-509. DOI: 10.4236/ajps.2020.113035



- McArtney S & Obermiller J D (2015). Effect of notching, 6-benzyladenine, and 6-benzyladenine plus gibberellin A<sub>4</sub>+A<sub>7</sub> on budbreak and shoot development from paradormant buds on the leader of young apple trees. *HortTechnology* 25(2): 233-237. DOI: 10.21273/HORTTECH.25.2.233
- Mika A; Buler Z & Krawiec A (2003). Effects of various methods of pruning apple trees after planting. *J. Fruit Ornament. Plant Res.* 11: 33-43
- Moghadam E G & Zamanipour M (2013). Induction of lateral branching in sweet cherry (*Prunus avium* L. cvs. "Siah Mashhad" & "Dovomras") trees in nursery. *J. Agric. Sci.* 5(3): 23-30. DOI: 10.5539/jas.v5n3p23
- Neri D; Mazzoni M; Zucconi F & Dradi G (2004). Feathering control in sweet cherry (*Prunus avium* L.) nursery, by deblading and cytokinin. *Acta Hort.* 636: 119-127. DOI: 10.17660/ActaHortic.2004.636.14
- Palmer J W; Diack R; Seymour S; Dayatilak D & Tustin D S (2005). New approaches to the alleviation of barewood in young apple trees. *J. Hort. Sci. Biotech.* 80 (5): 623-627. DOI: 10.1080/14620316.2005.11511988
- Quinlan J D (1976). Chemical induction of lateral branches (feathers). *Acta Hort.* 65: 129-138. DOI: 10.17660/ActaHortic.1978.65.20
- Quinlan J D & Tobutt K R (1990). Manipulating fruit tree chemically and genetically for improved performance. *HortScience* 25: 60-64. DOI: 10.21273/HORTSCI.25.1.60
- Radivojevic D D; Momirovic I S; Milivojevic J M; Velickovic M M; Oparnica C D & Lukic M M (2015). The influence of BA+GA<sub>4+7</sub> on formation of sylleptic shoots on one-year-old apple nursery trees. *J. Agric. Sci.* 60(1): 89-95
- Sadowski A; Mackiewicz M & Dziuban R (2007). Growth and early bearing of apple trees as affected by the type of nursery trees used for planting. *Acta Hort.* 732: 447-455. DOI: 10.17660/ActaHortic.2007.732.68
- Savini G; Neri D; Zucconi F & Mancini G (2007). Lateral shoot growth of apple, pear and cherry with selective disbudding on newly planted trees. *Acta Hort.* 732: 587-592. DOI: 10.17660/ActaHortic.2007.732.87
- Sosna I S (2016). Growth and cropping of two pear cultivars as affected by the type of nursery trees. *Hort. Res.* 24(2): 77-82. DOI: 10.1515/johr-2016-0023
- Stebbins R L (1992). Training apple trees in commercial orchards. Pacific Northwest Extension Publication Series No: 402, Washington
- Şahinoğlu A R; Atay E; Avcı S; Sarıtepe Y; Ernim C & Küden A B (2018). Formation of ideal tree canopy in newly planted sweet cherry orchards. Paper presented at the 30th International Horticultural Congress (IHC-2018)-Symposium 9, Evaluation of cultivars, rootstocks and management

- systems for sustainable production of deciduous fruit crops, 12-16 August 2018, Istanbul, Türkiye, Book of abstracts, p. 10
- Tworzoski T & Miller S (2007). Endogenous hormone concentrations and budbreak response to exogenous benzyl adenine in shoots of apple trees with two growth habits grown on three rootstocks. *J. Hortic. Sci. Biotech.* 82(6): 960-966, DOI: 10.1080/14620316.2007.11512333
- Vanderzande S; Hias N; Edge-Garza D; Costes E; Davey M W & Keulemans J (2016). Syllaptic branching in winter-headed apple (*Malus × domestica*) trees: accession-dependent responses and their relationships with other tree architectural characteristics. *Tree Genet. Genomes* 12: 87. DOI: 10.1007/s11295-016-1046-3
- Volz R K; Gibbs H M & Popenoe J (1994). Branch induction on apple nursery trees: effects of growth regulators and defoliation. *New Zeal. J. Crop Hort.* 22: 277-283. DOI: 10.1080/01140671.1994.9513836
- Wilson B F (2000). Apical control of branch growth and angle in woody plants. *Am. J. Bot.* 87: 601-607. DOI: 10.2307/2656846
- Wertheim S J & Webster D (2003). Propagation and Nursery Tree Quality. In: Apples: Botany, Production and Uses, Ferree D C & Warrington I J (eds.). CABI Publishing, Cambridge, 125-151
- Wertheim S J (2005). Pruning. In: Fundamentals of Temperate Zone Tree Fruit Production, Tromp J; Webster A D & Wertheim S J (eds.). Backhuys Publishers, Leiden, The Netherlands, 176-189
- Williams M W & Billingsly H D (1970). Increasing the number and crotch angles of primary branches of apple trees with cytokinins and gibberellic acid. *J. Am. Soc. Hortic. Sci.* 95: 649-651



# CHAPTER 4

## POLLINATION AND FRUIT SETTING IN OLIVE (*OLEA EUROPEAE* L.)

Cansu DÖLEK<sup>1</sup> & Mücahit Taha ÖZKAYA<sup>2</sup>

<sup>1</sup>(Dr.) Cukurova University, Kozan Vocational High School,  
Horticulture Department, Adana, Türkiye,  
e-mail: cansudolek.90@gmail.com

 0000-0001-7628-0676

<sup>2</sup>(Prof. Dr.) Ankara University, Faculty of Agriculture,  
Horticulture Department, Ankara, Türkiye,  
e-mail: ozkaya@agri.ankara.edu.tr

 0000-0002-6571-5985

### 1. Introduction

#### Shoot and Flower Morphology in the Olive Tree

In the olive plant, the biological cycle is completed in two years, and in the trees, the product is formed on shoots that formed previous year (about 15 months ago) (Varol 2016). The buds which remain dormant in the spring, can usually form vegetative shoots, while they bloom the following spring (Lavee 1998). Fernandez-Escobar *et al.* (1992) reported in their study that the physiological separation phase takes place in June-July, which is the hardening period of the nucleus (Figure 1). According to the phenological calendar of the olive tree in the Mediterranean basin, March is the period when the differentiation of flower buds continues, the flower petals and male organs are formed (Kaya 2006). Pansiot and Rebour (1964) report that the resting period of olives ends in April. In April, the buds begin to open and flower clusters begin to shoot from these buds (Bozkaya 2009). In each flower, petals develop first, and after a short time (about a week) the sepals differ. After about 2 weeks, the formation of the stamen (male organ) begins, and the pistil (female organ) is the last organ, develops after a few days. Each inflorescence differentiation takes 4-5 weeks (Lavee 1998).

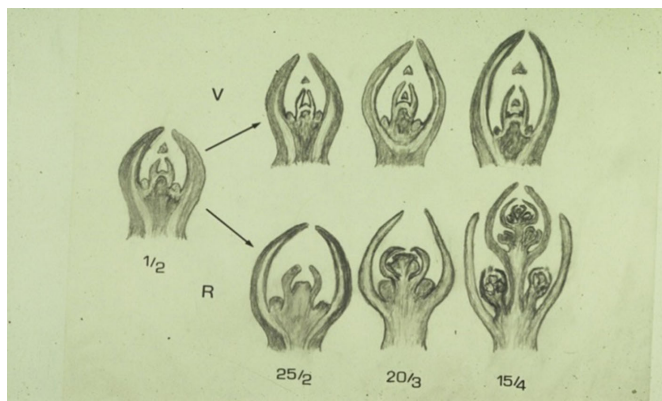


Figure 1. Development of vegetative (V) and generative (G) olive eyes in winter and spring (layout of leaves and flowers) (source: Lavee 1998).

The olive tree flowering consists of andromonoecious inflorescences containing a mixture of perfect (hermaphrodite) flowers and pistil aborted imperfect (male) flowers (Cuevas & Polito 2004). The olive flowers consist of a female organ consisting of a small, greenish Calyx, four white petals, two stamens with large anthers, a stigma, a short style, and an ovary containing four ovules (Figure 2c). Staminate (male) flowers, on the other hand, have a non-functional pistil as a result of pistil degeneration at varying stages of gynoecium (female) differentiation. Cross pollination results in earlier and higher fertilization levels compared to self pollination (Cuevas 1992). According to Martin (1990), as many as 500,000 flowers can be found on an adult Olive Tree; only 1-2% of these can turn into mature fruit due to intense destruction of flowers and small fruits as a result of competition. The anthers of olive flowers are usually large and contain large amounts of flower dust. After blooming, the anthers turn brown and are often shed together with petals (Lavee 1998) (Figure 2).

Sometimes, unusual flowers are identified on olive trees. The most common abnormality is the presence of 3 stamens and/or 5 petaling. Flowers with up to 6 stamens and up to eight petals have been identified. Some cultivars tend to form more abnormal flowers than others. Both the flower dust and ovary of these flowers are usually fertile. Pollination of olive flowers is caused usually by wind (Morettini & Pulselli 1953).

In the study on phenological observations made by Gencer Dölek (2020); the beginning of inflorescence, beginning of flowering, the 25% , 50% and 75% of flowering, the end of the flowering phases which are shown with BBCH codes in Gemlik, Domat and Sarı Ulak cultivars, are classified according to Sanz-Cortez (2002) study (Table 1).



**Figure 2.** Stages of development of the flower until the time of fertilization

A. Petals unopened flower, B. The 4-part petal appears to have separated anthers, C. Full blooming, D. Flower stage, whose anthers dried, E. Fertilization stage, F. Fruit set stage (Lavee *et al.* 1996)

## 2. Fertilization Biology in Olive and Factors Affecting It

### 2.1. Climate and Nutrition

Fruit set in olives is affected by high temperature, wind, fog, precipitation and humidity. In the context of phenological observations in a 3-year study conducted by Gencer Dölek (2020), the earliest inflorescences onset and blooming were observed in the Sarı Ulak cultivar; the latest flowering occurred in Gemlik in 2017 and 2018, and in Domat in 2019. In 2018, higher temperatures were detected in February and March compared to the other years, which brought the inflorescencing period earlier. The beginning of inflorescence was seen in the Sarı Ulak cultivar at the earliest in 2018 in connection with high temperatures, while it was detected on April 2 in 2019, and on April 3 in 2017. The period from the formation of inflorescence to the fruit set ranged from 31-37 days on average for 3 years. The average temperature during blooming and pollination periods is around 20°C. Laaribi *et al.* (2013) on self-and free pollination of the Chemlali Sfax olive cultivar supports our study. Gencer Dölek (2020) found the period between the formation of flower inflorescence and the fruit set 35-63 days.

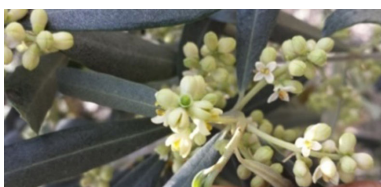


Table 1. Images of development periods are taken as a basis the phenological observations and shown by BBCH codes (Gencer Dölek 2020).

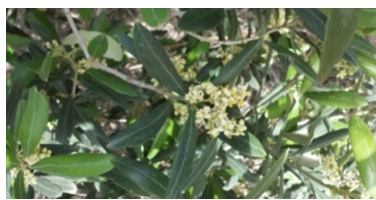
Beginning of inflorescence  
(BBCH Codes: 55)



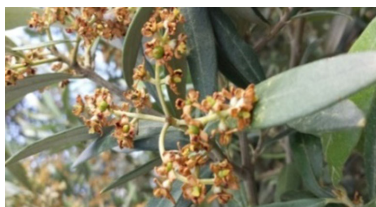
25% Blooming  
(BBCH Codes: 63)



75% Blooming  
(BBCH Codes: 67)



End of Blooming  
(BBCH Codes: 69)



50% Blooming\*  
(BBCH Codes: 65)



Full blooming (BBCH=65) occurred between April 3 and May 15 on average. It has been determined that the bud burst occurs early due to the fact that it is favorable until the last ten days of March in relation to an overall temperature increase. The temperature, which usually begins with 25°C after April 24, is suitable for full blooming.

Farinelli *et al.* (2006) observed that self-pollination may vary over the years due to different cultivars of; lighting, temperature, flower bud formation and climate factors.

The high temperature during pollination inhibits the growth of pollen tube in style, reducing self-fertilization (Seifi *et al.* 2012). The growth and fertilization percentage of the pollen tube in the style is affected by temperature, but it also depends on the genetic trait. Periodicity, on the other hand, represents a strategic mechanism for maintaining nutrient reserves for significant vegetative growth and

for relieving biotic and abiotic stresses in environments prone to macronutrient/micronutrient deficiencies in dry climates such as the Mediterranean Basin (Ayerza & Sibbett 2001). According to Beede and Goldhamer (1994), if water stress in trees occurs during the period of fruit set, a decrease in fruit set and an increase in periodicity are observed.

Rain during blooming reduces the distribution of pollen and also shortens the viability of pollen (Figure 3a). Dry desert winds observed from time to time in many aquaculture areas of the Mediterranean, although mostly due to their drying effect on the stigma, inhibiting the development of pollen tubes on the style and regressing the zygote on the ovary, can cause a decrease in yield (Lavee 1998). High temperatures and dry winds also affect pollen viability and the germination (Figure 3).

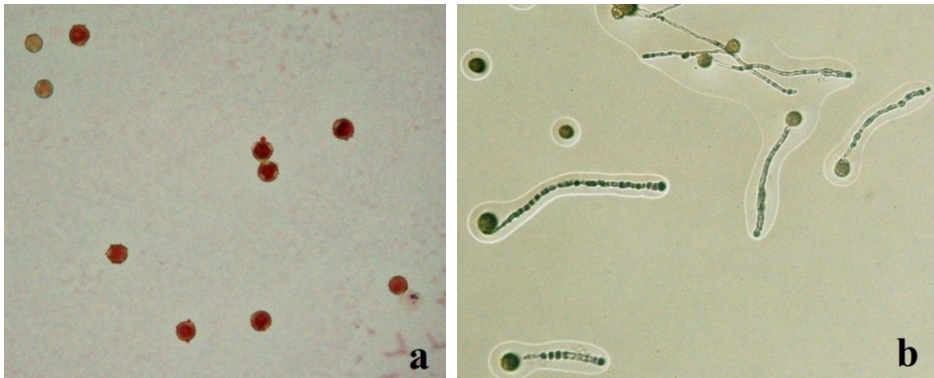


Figure 3. Images of pollen vitality (a) and germination (b) (Gencer Dölek, 2020)

Selak *et al.* (2013) reported in the study that; the low fertilization rate and low fruit set in plants are usually related with high and low temperatures. Higher temperatures increased dissonance reactions, and the pollen tubes became trapped somewhere between the stigma and the embryo sac.

During the blooming period of olive trees, the water requirement is high. During periods when winter rainfall is not stored and irrigation is not done, defloration occurs on olive trees that are stressed (Çeçen 1970). Lack of water in periods when fruit set occurs reduces the rate of fruit retention and increases the severity of periodicity (Beede & Goldhamer 1994).

Even if the nutritional status is unknown in many olive groves, fertilization programs are available. Leaf-nutrient analysis provides an indicator of the nutritional status of the tree and represents an important tool for determining fertilization requirements. The yield and the amount of nutrients removed through pruning can be of interest. Potassium is the most abundant element in

the olive fruit, and calcium the most abundant in the pruning material. Nitrogen is the second most abundant element in both fruits and pruning material. In accordance with these data, surveys and experiments conducted in different growing areas, the main nutritional imbalances that can affect the majority of olive orchards are represented by potassium deficiencies, mainly in drylands, calcium deficiencies, expected in acidic soils, and nitrogen overfertilization, since it is commonly applied in fertilization programs. Iron deficiencies in calcareous soils and other imbalances such as boron and zinc in some areas where these nutrients are not available are usually local. Boron excess is also common in some regions. Phosphorus is usually applied in fertilization programs, but it is very rare to achieve phosphorus deficiencies, as it is easily reused by trees and phosphorus removal is low (Fernandez-Escobara 2018).

## **2.2. Incompatibility**

One of the most important problems that can affect commercial fruit production in olive cultivation is its self-compatibility characteristic. According to Eti (2009), self-incompatibility is a condition in which fertilization cannot occur as a result of pollination with flower dust belonging to the same cultivar, although sexual organs and sexual cells in a flower develop healthy. This condition is completely genetic and is controlled by incompatibility genes (S genes).

Bradley *et al.* (1961) found that flower pollens belonging to different pollinator cultivars reach to the ovary faster and perform fertilization. Lombardo *et al.* (2006) noted that the use of pollinator cultivars will benefit in some cases, even in cultivars that are considered self-fertile (Mete *et al.* 2012).

Cuevas & Polito (1997) noted that during self-pollination, most the pollen tube cannot pass through the style to be fertilized and cannot reach to the ovule, while during cross pollination the pollen tube develops faster and passes into the ovary.

The shedding of male flowers in olives begins shortly after full blooming (Cuevas *et al.* 1995), and after the blooming period, the casting of unfertilized hermaphrodite flowers takes place (Rosati *et al.* 2011).

Cuevas *et al.* (2001) reported that if dusting design is required, the selected pollinator must meet certain requirements. The pollinator cultivar should be compatible with the main cultivar and should bloom at the same time and regularly. According to Palasciano *et al.* (2008), when choosing pollinator cultivars and breeding programs, the quality and quantity of live flower pollens produced per flower should be considered. In some cases, some cultivars may

be preferred as pollinators due to a more abundant and effective flower pollens production.

According to Cuevas & Polito (2004), the most obvious advantage of male flower production is the increase in the number of pollen available to ensure fertilization. This condition is especially important in anemophile species. A number of studies in olives have shown that the production and viability of flower pollens depends heavily on the cultivar (Rapoport 2008).

It has been reported that olive trees growing in areas where the air temperature reaches 41 degrees during the blooming period have seen more beaded fruit formation than in areas with low temperatures (Ayerza & Coates 2004). Low pollen viability (Lavee *et al.* 2002), self pollination (Sibbett *et al.* 1992) or generally poor pollination (Ayerza & Coates 2004) are factors that promote bead fruit formation in olive trees. The more inadequate fertilization, the higher the production of parthenocarpic fruit is observed (Sibbett *et al.* 1992; Castillo-Llanque *et al.* 2008).

Besnard *et al.* (2000) investigated inheritance and cytoplasmic diversity to determine the genetic basis of male infertility in wild and cultured olives grown in the Mediterranean Sea. Male infertility is a very common phenomenon in olives. The researchers noted that the male infertility trait is inherited by the mother.

Cuevas & Rallo (1990) noted that the proportion of full flowers in trees with low flower density was higher than in trees with more flowers. Guerin & Sedgley (2007) have explained that this situation is occurred by the fact that only a small number of flowers formed on the tree turn into fruit. Martins *et al.* (2006) reported that in some cases, abundant male flowers occur and there is a decrease in yield due to the lack of sufficient hermaphrodite flowers (Mete & Mısırlı 2009).

### ***2.3. Increase the number of male flowers***

Hartmann (1953) showed that winter chilling is mandatory for flower development. There has never been blooming in olives growing in heated greenhouses, where the winter chilling has been eliminated. Morettini (1951) reported that there is little need for chilling for differentiation to occur in flower buds. If chilling has been sufficient, also differentiation also occurs at high temperatures that are not stimulating. The sensitivity of olives to stimulating conditions depends on the previous year's crop. Trees that form excess crops need a longer and precise chilling. In the absence of stimulating conditions, there is an increase in the rate of male flowers (Ulger 1997).

Cuevas & Polito (1997) stated to themselves that during pollination, most flower dust pollen tube were unable to pass through the style to have fertilization and reach the seed draft, while in foreign pollination, the flower dust pollen tube developed faster and moved to the ovary.

### 3. Studies on Fertilization Biology in Olives

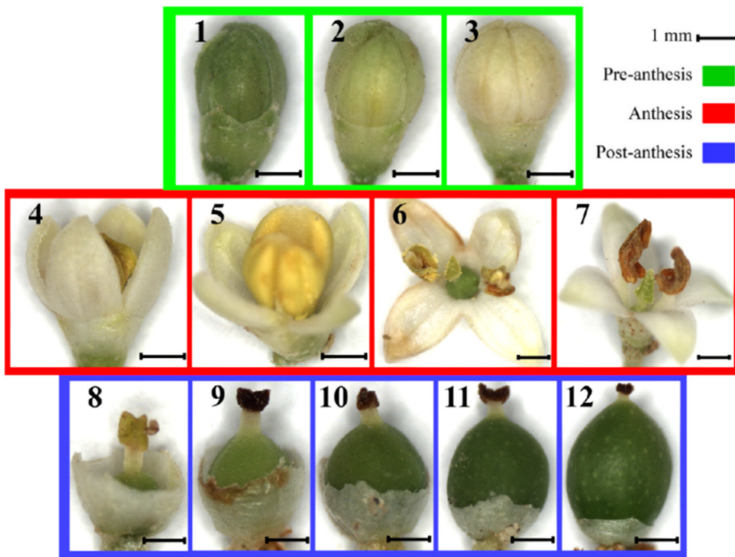
Mete & Mısırlı (2009) carried out free pollination, self-pollination and cross-pollination applications in order to determine the fruit set rate of Domat, Edincik Su, Eşek olive (Ödemiş), Kilis yağlık, Samanlı, Uslu and Arbequina olive cultivars within the scope of their two-year experiment. The flowers on the inflorescences were counted and labeled while they were still in the balloon stage (BBCH=59). Pollens belonging to cultivars used in mutual pollination were obtained with the help of isolation sacs. The first pollination was carried out by changing the isolation sacs when 40-50% of the flowers in the examined cultivars opened (BBCH=65), and the second pollination was carried out when 70-80% of the flowers opened (BBCH=67). Full flower counts were made after the anthers and petals were shed, while the sacs were removed.

Koubouris *et al.* (2010) investigated the effect of three different pollination states (self-, cross- and free-) on the formation of shotberry (beaded fruit, seedless fruit = parthenocarpy) of Koroneiki, Kalamata, Mastoidis and Amigdalolia cultivars for three consecutive years. Low air temperature during the blooming period increased the formation of parthenocarpy. When the Koroneiki and Mastoidis cultivars were used as cross pollinators, parthenocarpyc fruit formation was decreased. Cross pollination of the amygdalolia cultivar with the koroneiki and Mastoidis cultivars led to the formation of the lowest beaded fruit. The results of this study show that the tendency of parthenocarpyc fruit formation is affected by genetic factors and this ratio varies between different cultivars. Orlandi *et al.* (2005) reported that the effective pollination time of most olive cultivars in central Italy is 4 days and that olives play a very important role in the breeding process.

Selak *et al.* (2011) free pollination, self-pollination, as well as cross pollination with Leccino and Pendolino (Italian) cultivars were performed to determine the reproductivity status of the most important olive cultivars (Drobnica, Lastovka, Levantinka ve Oblica) in Croatia. The Italian cultivar Leccino has been evaluated as a successful cultivar in cross pollination for most Croatian cultivars. High success in cross pollination was recorded for Polantinka and Oblica cultivars. Lastovka, Leccino and Oblica cultivars were also found

to be mutually compatible at the same time. Pinillos & Cuevas (2009) found that olive cultivars located 250 m to 500 m from Monovarietal Picual gardens established with a single cultivar in Spain act as pollinators and increase the yield of this cultivar, which is incompatible with itself.

The aim of the studies conducted by Shamer *et al.* (2014) in olives is to determine the most suitable pollinator for the Barnea cultivar. Researchers have concluded that the Arbequina cultivar exhibits a much lower rate of fruit retention, and the Barnea cultivar is almost self-pollination. It is not enough that flowers belonging to pollinator and pollinated cultivars are open at the same time. At the same time, effective pollination times should overlap depending on stigma receptivity and pollen viability. The Picual cultivar has been identified as the most important pollinator in commercial olive groves, even if they are far from Barnea trees. Stages of development of olive flower according to Shemer *et al.* (2014) is divided into three periods (Figure 4).



**Figure 4.** The developmental stages of the olive flower are divided into three periods: \* pre-blooming (stages 1-3); \* blooming (stages 4-7), and \* post-blooming (stages 8-12) (Shemer *et al.* 2014).

Korkmaz & Ak (2018) determined the self-productivity States of 5 different olive cultivars (Yuvarlak Halhalı, Nizip Yağlık, Domat, Gemlik and Wild) within the borders of Şanlıurfa. The highest fruit set rate 20 days after full flowering was determined in the application of Yuvarlak Halhalı X free pollination with



18.58%, followed by Nizip Yağlık X self-pollination with 17.52% and Gemlik X free pollination with 17.23%. The lowest value was obtained from the application of a Yuvarlak Halhalı (self-pollination) with 8.66%.

Mete *et al.* (2019) investigated the self-effectivity states of Saurani, Nizip Yağlık and Uslu cultivars by performing free pollination, cross pollination and self pollination applications. In the study, the Nizip Yağlık cultivar was partially evaluated as self-efficient. It is believed that the Memecik and Kilis Yağlık cultivars may be suitable pollinators for the Nizip Yağlık cultivar. The Saurani olive cultivar has been found to be self-efficient. Halhalı Çelebi, Gemlik, Memecik and Nizip Yağlık cultivars have been proposed as suitable pollinators to increase fruit set. A Uslu cultivar has also been identified as self-efficient. Gemlik, Memecik and Erkence cultivars were found to be helpful in increasing fruit set.

Sanchez-Estrada & Cuevas (2019) carried out self, free and cross pollination applications of Sevillano, Barouni, Picual, Pendolino, Mission cultivars in both monovarietal and multivarietal Manzanilla orchards in order to determine whether there is a pollination deficit in northern Mexico. The results confirmed that Manzanilla was incompatible with itself. Free pollination in the Monovarietal garden did not increase fruit set, but fruit set significantly increased in cross pollination applications. In addition to the low rate of pollen in self-pollination applications, decreased germination and delayed growth of pollen tube were observed from time to time, self-incompatibility reactions were emphasized. For the Manzanilla cultivar, the Barouni cultivar is proposed as a fertile pollinator.

Gencer Dölek (2020) in her three-year study on the fertilization biology of Gemlik, Sarı Ulak and Domat olive cultivars in Mersin province, she conducted free pollination, self-pollination and cross pollination applications. These cultivars are also the most popular olive cultivars widely cultivated in the region, and in this study, it was determined that if these cultivars are grown in the same garden, they mutually pollinate each other. The flowers on the selected branches of the trees were counted (BBCH=59) before the petals opened and isolated with agril bags that could take air, pass light, but do not pass pollen from the outside. Light-passing white greasy sacciform paper bags were used to obtain pollens that will be used in self-pollination and cross pollination applications. Using fresh pollens obtained 1 day after the insertion of these bags, cross pollination operations were performed 3 times during periods when 25%, 50% and 75% of the flowers in agril bags opened.

When a general assessment was made for all three cultivars; fruit set levels determined according to hermaphrodite flower in the first year, the highest value in terms of application averages was obtained from free pollination in Domat and Sarı Ulak cultivars, cross pollination with Sarı Ulak in Gemlik cultivar (Table 2). The lowest values were determined in self-pollination application in all cultivars. The highest values in terms of direction averages were found in the south direction of the Domat cultivar, in the east direction of the Gemlik cultivar and in the North direction of the Sarı Ulak cultivar, while the lowest values were found in the west direction of all cultivars. In the second year, the highest values were obtained from free pollination application in Gemlik cultivar and foreign pollination application with Gemlik in Sarı Ulak cultivar. The lowest values were found in self-pollination application. In the third year, the highest values in terms of application averages were found in free pollination applications in Domat and Sarı Ulak cultivars, and in Gemlik cultivars in cross pollination applications with Sarı Ulak cultivar. The lowest values were determined in cross pollination applications with Gemlik in the Domat cultivar, in self-pollination applications with Gemlik in the Gemlik cultivar and in cross pollination applications with Gemlik in the Sarı Ulak cultivar. The highest values in terms of direction averages were obtained in the east direction in Domat and Gemlik cultivars and in the west direction in Sarı Ulak cultivars. The lowest values were found in the Western direction in the Domat and Gemlik cultivars, and in the southern direction in the Sarı Ulak cultivar (Table 2).

In terms of fruit set relative to hermaphrodite flower, it was remarkable that in all applications made in Domat cultivar, quite high levels of fruit retention values were achieved compared to the fruit retention rates obtained from applications made in Gemlik and Sarı Ulak cultivars (Table 2).

Gencer Dölek (2020), in the study in which evaluated the percentages of fruit setting according to hermaphrodite flower for all years and cultivars, determined that the highest values were obtained from free pollination practices in all cultivars and years, except Gemlik in the first and third year and Sarı Ulak cultivar in the second year. The lowest values were obtained in self-pollination applications in all cultivars in the first and second years, in Gemlik cultivars in self-pollination applications in the third year, and in Gemlik and Sarı Ulak cultivars in cross-pollination applications (Table2).

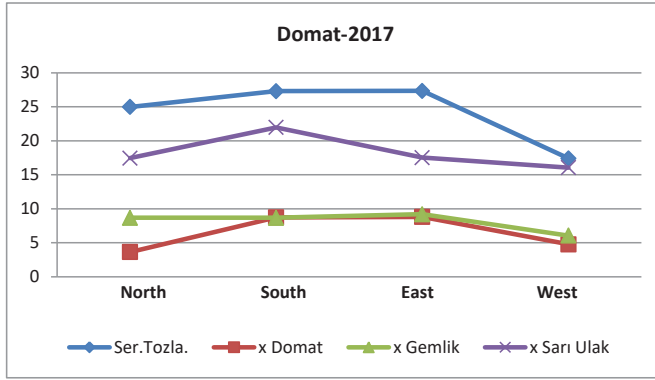
**Table 2.** Fruit set levels determined according to hermaphrodite flower in different pollination applications in olive cultivars examined within the scope of the trial (%)<sup>1,2</sup> (Gencer Dölek 2020).

	Year	Application	North	South	East	West	Avg.	
Domat	2017	Free pollination	24.98	27.29	27.33	17.41	24.25 A	
		x Domat	3.65	8.75	8.82	4.79	6.50 C	
		x Gemlik	8.69	8.69	9.20	6.06	8.16 C	
		x Sarı Ulak	17.46	21.97	17.53	16.06	18.26 B	
		Avg.	13.69 AB	16.68 A	15.72 A	11.08 B		
	2018	Alternate Bearing						
	2019	Free pollination	9.41	8.83	10.59	7.71	9.14 A	
		x Domat	3.94	4.76	7.19	3.76	4.91 BC	
		x Gemlik	3.70	4.48	6.02	3.26	4.37 C	
		x Sarı Ulak	6.80	6.84	8.03	4.49	6.54 B	
Avg.		5.96 AB	6.23 AB	7.96 A	4.81 B			
Gemlik	2017	Free pollination	2.90	2.50	3.22	2.32	2.74 B	
		x Domat	2.04	0.98	0.99	1.21	1.31 BC	
		x Gemlik	0.65	0.39	0.38	0.48	0.48 C	
		x Sarı Ulak	10.60	6.76	12.23	6.58	9.04 A	
		Avg.	4.05	2.66	4.21	2.65		
	2018	Free pollination	4.19	3.37	3.96	2.23	3.44 A	
		x Domat	Alternate Bearing					
		x Gemlik	1.48	0.86	1.55	1.16	1.26 B	
		x Sarı Ulak	1.20	0.95	1.88	1.89	1.48 B	
		Avg.	2.29	1.73	2.47	1.76		
	2019	Free pollination	2.33	1.14	2.90	1.71	2.02 A	
		x Domat	1.50	2.18	1.68	0.99	1.59 A	
		x Gemlik	1.05	0.03	1.42	0.28	0.69 B	
		x Sarı Ulak	1.97	2.22	2.33	1.65	2.04 A	
		Avg.	1.71 AB	1.39 B	2.09 A	1.16 B		
Sarı Ulak	2017	Free pollination	9.20	6.51	10.77	5.65	8.03 A	
		x Domat	4.44	4.40	1.85	3.96	3.66 B	
		x Gemlik	4.57	2.89	4.08	3.28	3.71 B	
		x Sarı Ulak	0.96	1.31	1.32	1.75	1.33 C	
		Avg.	4.79	3.78	4.51	3.66		
	2018	Free pollination	1.51	1.65	2.63	1.98	1.94 A	
		x Domat	Alternate Bearing					
		x Gemlik	2.12	2.46	2.07	2.15	2.20 A	
		x Sarı Ulak	1.71	0.79	0.80	0.89	1.05 B	
		Avg.	1.78	1.63	1.83	1.68		
	2019	Free pollination	1.43	0.38	1.30	2.83	1.49	
		x Domat	1.16	0.99	1.07	1.37	1.15	
		x Gemlik	1.62	0.45	0.59	1.06	0.93	
		x Sarı Ulak	0.64	0.99	1.10	1.22	0.99	
		Avg.	1.21 AB	0.71 B	1.01 AB	1.62 A		

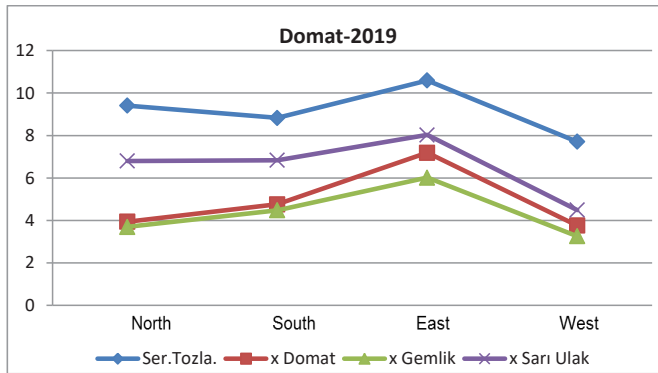
1. Differences between the averages shown in separate letters in the same column were found to be statistically significant.

2. In 2018, the Domat cultivar was unavailable due to periodicity.

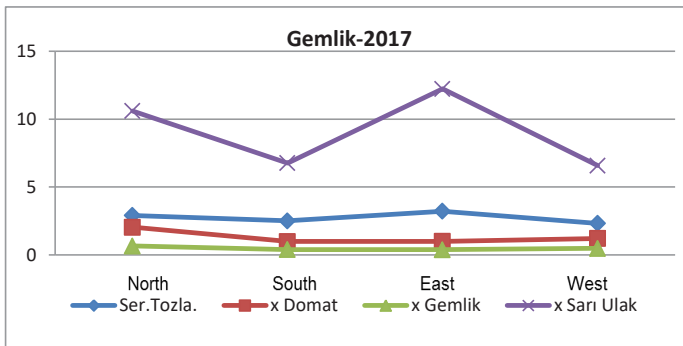
N. S.: Not significant; \*, p<0.05; \*\*, p<0.01; \*\*\* p<0.001



In the graph, it was seen that there was no difference between the directions in the applications of the Domat cultivar, but the applications of Free Pollination and Pollination with Sari Ulak gave high values.

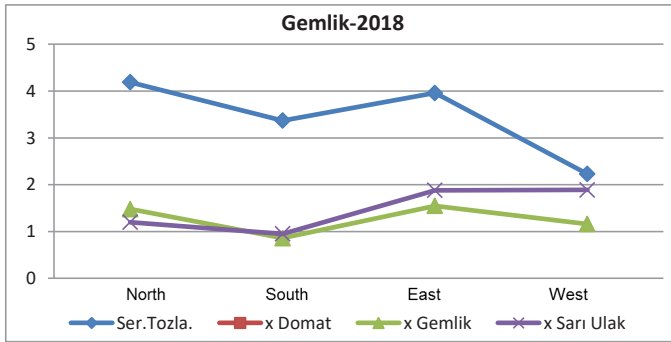


In 2019, it is seen that there is no difference between the directions in terms of applications in the graph of the Domat cultivar, but that the foreign pollination applications with Free Pollination and Sari Ulak constitute the highest values.

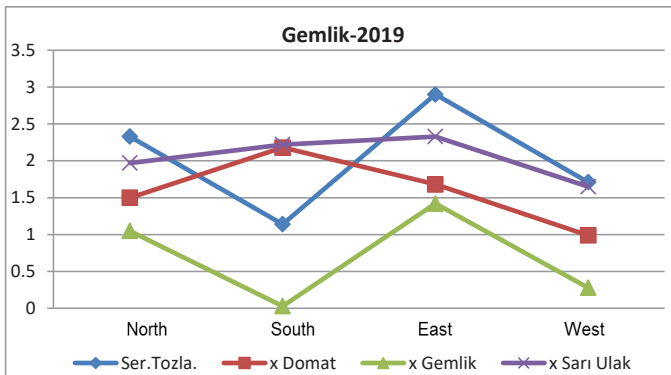


In 2017, it was found that there was no difference between the directions in terms of applications in the graph of the Gemlik cultivar, but the North and East

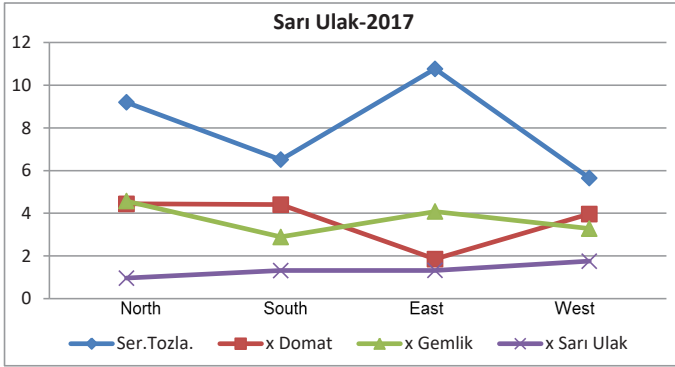
directions gave high values in the application of foreign pollination with Sari Ulak. While all applications showed similar values to each other, the highest fruit set was determined in the application of foreign pollination with the Sari Ulak cultivar of Gemlik cultivar.



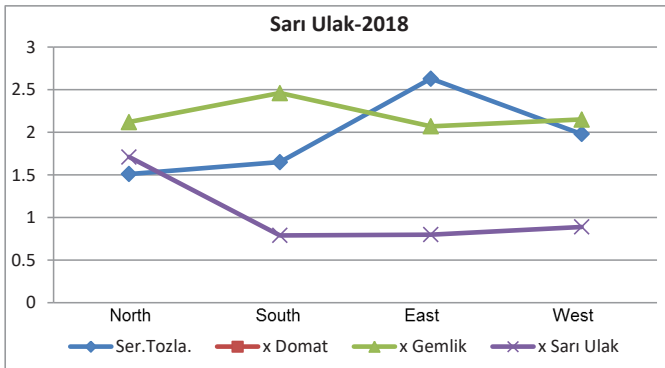
In 2018, it was observed that there was not much difference between the directions in terms of applications in the graph of gemlik cultivar, but that the application of Free Pollination had higher fruit set values than other applications.



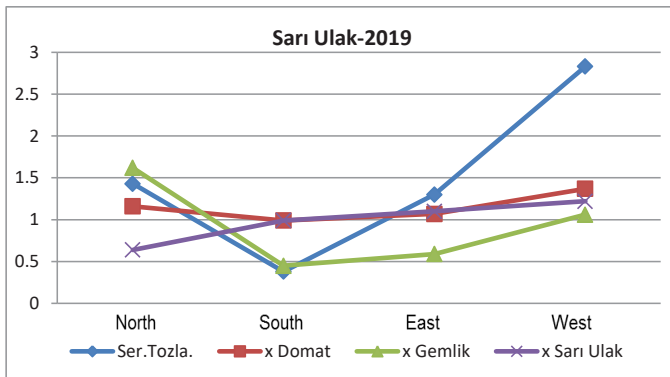
In the graph of the Gemlik cultivar in 2019, it was determined that fruit set increased in the eastern directions in terms of applications, and there were similar results among other directions.



In 2017, the graph of the Sarı Ulak cultivar showed similar values in terms of applications, while the highest values were found in Free Pollination applications.



In 2018, it was seen that there was no difference between the directions in terms of applications in the graphic of the Sarı Ulak cultivar, but the Free Pollination application had higher fruit set values than other applications.





In 2019, the highest fruit retention values in terms of applications were determined in the west direction in the graph of the Sarı Ulak cultivar, while similar results were seen when other directions were evaluated.



**Figure 5.** Cases related to the development of fruit in the Sarı Ulak cultivar. a. Normally developed and beaded fruits on the tree. b. Normal developed fruits (left), parthenocarpic fruits (middle) and beaded fruits (right).

In her study on beaded fruit ratio, Gencer Dölek (2020) found the highest value in terms of application averages in the Sarı Ulak cultivar in the first year in Self-pollination applications and the lowest value in cross pollination applications with Gemlik. In the second year, the highest values in terms of application averages were obtained similar to each other in the Self pollination application, in the cross pollination application with Domat and in the cross pollination application in Gemlik. The lowest value was determined from the application of free pollination.

#### 4. Conclusion

There are many reasons for the lack of pollination in the wind-pollinated olive tree. Its:

- 1) Establishment of monovariate gardens with incompatible varieties
- 2) Lack of pollination due to ecology (such as high temperature, constant rain, dry wind)
- 3) Increase in the number of male flowers

The return of 1-2% of the flowers blooming in the olive tree to fruit means a good yield. However, in some years, the fact that the blooming flowers fruit set at less than 1% means a low yield.

Artificial pollination can be a successful application in order to prevent low yield in the olive tree. Artificial pollination has two stages: pollen collection and pollen spraying.

## References

- Ayerza R & Coates W (2004). Supplemental pollination–increasing olive (*Olea europaea* L.) yields in hot, arid environments. *Experimental agriculture* 40; 481-491.
- Ayerza R & Sibbett GS (2001). Thermal adaptability of olive (*Olea europaea* L.) to the arid chaco of Argentina. *Agriculture ecosystem and environment* 84(3); 277-285.
- Beede RH & Goldhamer DA (1994). Olive irrigation management in olive production, Manual University Of California. Publication 3353.
- Besnard G; Khadari B; Villemur P & Berville A (2000). Cytoplasmic male sterility in the olive (*Olea europaea* L.), theoretical and applied genetics 100(7); 1018-1024.
- Bozkaya F (2009). Dolu yılında zeytin (*Olea Europaea* L.) bitkisinde mineral bitki besin maddelerinin mevsimsel değişiminin incelenmesi. Yüksek lisans tezi. Adnan Menderes Üniversitesi fen bilimleri enstitüsü Aydın.
- Bradley MV; Griggs WH & Hartmann HT (1961). Studies on self- and cross-pollination of olives under varying temperature conditions. *California agriculture* 15(3); 4-5.
- Castillo-Llanque FJ; Casilla EM & Baumann H (2008). “Effect of cross-pollination in “Criolla” olives: a typical cultivar of Peru.” *Acta horticulturae* 791; 275-278.
- Cuevas J (1992). Incompatibilidad polen-pistilo, procesos gaméticos y fructificación de cultivares de olivo (*Olea europaea* L.). Ph. D. Thesis. Universidad de Córdoba, Spain. p. 265.
- Cuevas J & Polito VS (2004). The role of staminate flowers in the breeding system of *Olea europaea* (Oleaceae): an andromonoecious, wind-pollinated taxon. *Annals of botany* 93; 547-553.
- Cuevas J & Rallo L (1990). Response to cross-pollination in olive trees with different levels of flowering. *Acta hort.* 286; 179-182.
- Cuevas J & Polito VS (1997). Compatibility relationships in ‘Manzanilla’ olive. *Horticultural science* 32; 1056-1058.
- Cuevas J; Diaz-Hermoso AJ; Galian D; Hueso JJ; Pinillos V; Prieto M; Sola D & Polito VS (2001). Response to cross-pollination and choice of pollinisers for

- the olive cultivars (*Olea europaea* L.) ‘Manzanilla de Sevilla’, ‘Hojiblanca’ and ‘Picual’. *Olivae* 85; 26-32.
- Cuevas J; Rapoport HF & Rallo L (1995). “Relationships among reproductive processes and fruitlet abscission in “Arbequina” olive,” *Advances in horticultural science*, 9(2); 92-96.
- Çeçen K (1970). Zeytin ağaçlarının su ihtiyaçlarının tespiti ile ilgili bir çalışma. Tarım bakanlığı bornova zeytincilik araştırma enst. yayımları no:6.
- Eti S (2009). Döllenme biyolojisi lisansüstü doktora ders notları, Ç.Ü. ziraat fakültesi bahçe bitkileri bölümü Adana (Yayınlanmamış).
- Farinelli D; Boco M & Tombesi A (2006). Results of four years of observations on self – sterility behaviour of several olive cultivars and significance of cross - pollination. – *Proceedings second international seminar olivebioteq 2006 Mazara del vallo (TP) 5-10 November 275-282.*
- Fernández-Escobar R; Benlloch M; Navarro L; Martin GC (1992). The time of floral induction on the olive. *J. Amer. soc. hort. sci.*, 117, s. 304-307.
- Fernandez-Escobara R (2018). Trends in olive nutrition. *ISHS Acta horticulturae 1199: VIII International olive symposium. DOI: 10.17660/ActaHortic.2018.1199.35*
- Gencer Dölek C (2020). Gemlik, Sarı Ulak ve Domat zeytin çeşitlerinin döllenme biyolojileri üzerine araştırmalar. Ankara Üniversitesi fen bilimleri enstitüsü bahçe bitkileri anabilim dalı. Doktora tezi Ankara 2020.
- Guerin J & Sedgley M (2007). Cross-pollination in olive cultivars. RIRDC publication no 07/169. RIRDC project no UA-65A.
- Hartmann HT (1953). Effect of winter-chilling on fruitfulness and vegetative growth in the olive. *Proc. amer. soc. hort. sci.* 62;184-190.
- Kaya Ü (2006). Zeytinde üretim metodları, Ankara.
- Korkmaz Ş & Ak BE (2018). GAP bölgesinde yetiştirilen bazı zeytin çeşitlerinin kendine verimlilik durumlarının belirlenmesi. *Harran tarım ve gıda bilimleri dergisi*, 22(4); 471-477.
- Koubouris GC; Metzidakis IT and Vasilakakis MD (2010). Influence of cross-pollination on the development of parthenocarpic olive (*Olea europaea*) fruits (shotberries). *Experimental agriculture* 46(1); 67-76.
- Laaribi I; Mezghani MA & Mars M (2013). Study of the floral phenology and inflorescence characteristics of selections of olive obtained by controlled pollination in relation to climatic conditions. *ARPN Journal of science and technology*. 3(8) ISSN 2225-7217.
- Lavee S (1998). Zeytinin biyolojisi ve fizyolojisi. Dünya zeytin ansiklopedisi uluslararası zeytinyağı konseyi, İspanya.

- Lavee S; Rallo L; Rapaport HF & Troncosa A (1996). The floral biology of the olive: Effect of flower number, type and distribution on fruitset. *Scientia horticulturae* 66; 149-158.
- Lavee S; Taryan J; Levin J & Haskal A (2002). The significance of cross-pollination for various olive cultivars under irrigated intensive growing conditions. *Olivae* 91; 25-36.
- Lombardo N; Alessandrino M; Godino G and Madeo A (2006). Comparative observations regarding the floral biology of 150 Italian olive (*Olea europaea* L.) cultivars. *Adv. hort. sci.* 20(4); 247-255.
- Martin GC (1990). Olive flower and fruit population dynamics. *Acta horticulturae* 286; 141-153.
- Martins PC; Cordeiro AM & Rapoport HF (2006). Flower quality in orchards of olive, *Olea europaea* L., cv. Morisca, *Advances in horticultural science* 20(4); 262-266.
- Mete N; Çetin Ö; Hakan M; Kaya H; Sefer F; Uluçay N; Güloğlu U; Gül H & Sezgin O (2019). Nizip Yağlık, Saurani ve Uslu zeytin çeşitlerinin dölleme biyolojilerinin araştırılması. *ADÜ ziraat dergisi*, 6(1); 1-5.
- Mete N; Mısırlı A & Çetin Ö (2012). Determining the biology of fertilization and pollinators in some olive cultivars. *Proceedings of the 4th international conference on "Olive Culture and Biotechnology of Olive Tree Products"*, 69-74.
- Mete N & Mısırlı A (2009). Bazı zeytin çeşitlerinin dölleme biyolojisi üzerinde araştırmalar. Yüksek lisans tezi. Ege Üniversitesi Fen Bilimleri Enstitüsü İzmir. Tagem proje no: BBAD/2008/1/06/01 İzmir.
- Morettini A (1951). *Influenza della Defogliazione dell' Olive*. ann. sper. agrar. 5; 309-329 Roma.
- Morettini A & Pulselli A (1953). *L'Azione del vento nel trasporto del polline dell'olivo*". *Annali della sper. agraria*. (N.W.). Roma.
- Orlandi F; Romano B & Fornaciari M (2005). Effective pollination period estimation in olive (*Olea europaea* L.): a pollen monitoring application. *Scientia Horticulturae* 105(3); 313-318.
- Palasciano M; Ferrara G & Camposeo S (2008). Pollen production by popular olive cultivars. *Acta Horticulturae*: <https://www.researchgate.net/publication/235957747>. Erişim Tarihi: 05.10.2019.
- Pansiot FP & Rebour N (1964). (Translate: Aksu S & Kantar M), *Zeytincilikte gelişmeler*. Tarım ve köy işleri bakanlığı. Zeytincilik araştırma enstitüsü. Yayın no. 3 Bornova/ İzmir.

- Pinillos V & Cuevas J (2009). Open-Pollination provides sufficient levels of cross-pollen in spanish monovarietal olive orchards. HortScience: a publication of the American society for horticultural science 44(2); 499-502.
- Rapoport HF (2008). Botánica y Morfología. In: Barranco, D. (ed). El cultivo del olivo. Madrid: Junta de Andalucía y Ediciones Mundi-Prensa.(37-61).
- Rosati A; Caporali S; Paoletti A & Famiani F (2011). "Pistil abortion is related to ovary mass in olive (*Olea europaea L.*)," Scientia horticulturae, 127(4); 515-519.
- Sanchez-Estrada A & Cuevas J (2019). Pollination strategies to improve fruit set in orchards of 'Manzanillo' olive in a nontraditional producing country, Mexico. American society for horticultural science. Volume 29 (2019): Issue 3 (Jun 2019). Page: 258–264.
- Sanz-Cortés F; Martínez-Calvo J; Badenes ML; Bleiholder H; Hack H; Llacer G & Meier U (2002). Phenological growth stages of olive trees (*Olea europaea L.*). Annals of applied biology 140(2); 151-157.
- Seifi E; Guerin J; Kaiser B & Sedgley M (2012). Sexual compatibility of the olive cultivar 'Kalamata' assessed by paternity analysis. Spanish J. Agric. Res. 10; 731-40.
- Selak VG; Perica S; Ban SG & Poljak M (2013). The effect of temperature and genotype on pollen performance in olive (*Olea europaea L.*). Scientia Horticulturae 156; 38-46.
- Selak VG; Perica S; Ban SG & Raduni M (2011). Reproductive success after self-pollination and cross-pollination of olive cultivars in Croatia. Hortscience 46 (2); 186-191.
- Shemer A; Biton I; Many Y; Vaknin Y; Lavee S; Avidan B & Ben-Ari G (2014). The olive cultivar 'Picual' is an optimal donor for 'Barnea'. Scientia Hort. 172; 278-284.
- Sibbett GS; Freeman M; Ferguson L & Polito VS (1992). Effect of topically applied "Sevillano" pollen on normal-seeded and parthenocarpic "shotberry" fruit set of "Manzanilla" olive. HortTechnology 2; 228-230.
- Ülger S (1997). Zeytinlerde periyodiste ve çiçek tomurcuğu oluşumu üzerine içsel büyüme hormonlarının etkilerinin saptanması. Doktora tezi. Akdeniz Üniversitesi fen bilimleri enstitüsü Antalya.
- Varol N (2006). Zeytinde Periyodiste. Zeytin yetiştiriciliği. Zeytincilik araştırma enstitüsü. Yayın no:61 İzmir.

# CHAPTER 5

## LED LIGHTING AND ROBOTIC ARM TECHNOLOGIES FOR PLANT PRODUCTION

Umur Ulaş HARMAN<sup>1</sup> & Özge HORZUM<sup>2</sup> & Köksal DEMİR<sup>3</sup>

<sup>1</sup>(M.Sc. Mech.Eng.), Colorado School of Mines, Golden, Colorado, USA,  
e-mail: uuharman@gmail.com

 0000-0002-7210-6774

<sup>2</sup>(Dr.), Ankara University, Faculty of Agriculture, Department of Horticulture,  
Ankara, Türkiye, e-mail: ozupek@agri.ankara.edu.tr

 0000-0003-2030-5613

<sup>3</sup>(Prof. Dr.), Ankara University, Faculty of Agriculture, Department of  
Horticulture, Ankara, Türkiye, e-mail: koksaldem@gmail.com

 0000-0001-6120-7249

### 1. Introduction

Light is an environmental factor that has significant effects on the life of all living things. It consists of photons, behaves like a particle and a wave simultaneously, and carries energy in all directions. Although the wavelengths that affect the human eye are fall in the range of 380-760 nm, plants can show responses to the broad interval of light wavelengths with their photoreceptors. Different wavelengths have different effects at every stage of the growth and development of plants. With LED (Light Emitting Diode) technology development, we can see that one can support plants' needs with the desired wavelengths. Beyond that, we can use LED light sources to support or replace daylight since natural light resources are generally not under our control. Significant changes in soil, water, climate, and increasing food demand made us think profoundly about finding new and more efficient ways to grow plants. Thanks to recent improvements in LED technology, plant production in



controlled areas has gained a different dimension, and the LED technology itself has rapidly gained significant importance for our future.

## 2. World Population and Food

The world population is approximately 7.8 billion people, according to 2020 data. More than 2 billion people do not have enough food today. Moreover, it is estimated that the population will approach 10 billion in 2050, which will lead to a 70-100% increase in food demand. In the future, hunger will emerge as a major problem in the world. Thus, increasing food production and efficiency is among the most important goals. This target will increase the pressure on natural resources, the ecological system, and the agriculture sector. Despite the high population growth, food production is not at the same rate (Anonymous 2021a). We use more soil, water, and other natural resources for agricultural purposes to reach the food demand. However, the growth rate in the sector will not be enough to eliminate the predicted hunger until 2050.

In plant production, 6.62 billion tons of product was acquired in 7.80 billion hectares in 2000, and this production was increased to 9.86 billion tons in 11.29 billion hectares in 2020. This amount was insufficient in terms of food needs, and 768 million people in 2000 and 800 million in 2020 were among the malnourished population. Difference between the food supply and demand will continue to increase in the future (Godfray *et al.* 2010, Anonymous 2021a, Anonymous 2021b). Figure 1 shows the population change projection of developed and developing countries over the years.

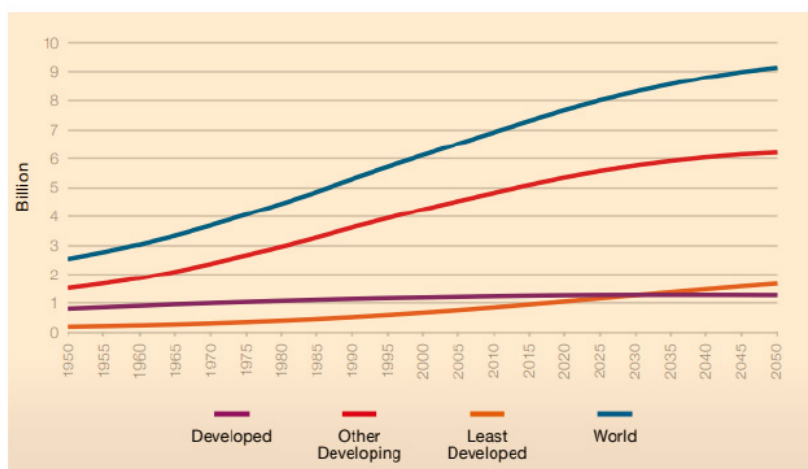


Fig.1. Population changes in developed and developing countries by years (Van der Mensbrugge *et al.* 2009, Anonymous 2021a)

In addition to the limited agricultural area, water scarcity is another future threatening parameter. 97.5% of the water consists of saltwater in the seas and oceans. Only 2.5% of the existing water is drinkable and can be used directly for agriculture. Furthermore, the unconscious use of water in agriculture and industrialization rapidly reduces our clean water resources, and globalization increases pollution in the water resources. Today, 18% of the world's population cannot benefit from clean potable water, and it is predicted that the population in water-scarce regions will increase six times by 2025. Furthermore, the water used in agriculture is expected to increase by 17% in 2025 because of the increasing population and food demand (Anonymous 2021a). Our existing natural water resources will be insufficient to meet the amount of water needed. In order to meet the growing food need in the future, agricultural production should be done by consuming less water. At the same time, it is a necessity to make sustainable production. LED technologies would open doors of more sustainable, less water-consuming in-door plant growth.

### 3. Effects of Light on Plants

LEDs have a long life and high luminous efficiency. With the LEDs used in plant production, desired wavelengths and mixtures can be used in plant growth. Studies about the effects of lighting on the growth and development of plants are limited. These researches on this subject have increased rapidly in recent years. Light is a particle of energy. Their movements are in the form of waves. The distance between the two crests of the wave is called the wavelength. Rays of different wavelengths are refracted at different angles in the prism, forming a spectrum. The wavelengths that the human eye can see vary between 380 nm and 760 nm. People can see the wavelength range between these two limits (Erim 1999, Rabara *et al.* 2017). Light is one of the most critical environmental factors affecting plant growth and development. Artificial light sources have been one of the most critical issues in indoor cultivation. Plants need light not only for photosynthesis but also for regulating their development. The sensitivity of plants to light ranges from UV to far-red radiation. The stratospheric ozone layer and the atmosphere absorb the UV-C portion of the ultraviolet (100-280 nm). Only UV-A (315-400 nm) and UV-B (280-315 nm) radiations can reach plants. The visible light spectrum (400-700 nm) is the primary wavelengths detected by plant photoreceptors and pigments. It consists of blue (400-500 nm) and red (600-700 nm), and to a lesser extent, green (500-600 nm) radiation. A small part of the light spectrum close to infrared radiation, such as far-red (730 nm), is perceived by phytochromes and is vital for plant growth (Huché-Thélier

*et al.* 2016, Koç *et al.* 2009). The wavelengths and activities of the light that are effective in plant growth are shown in Figure 2.

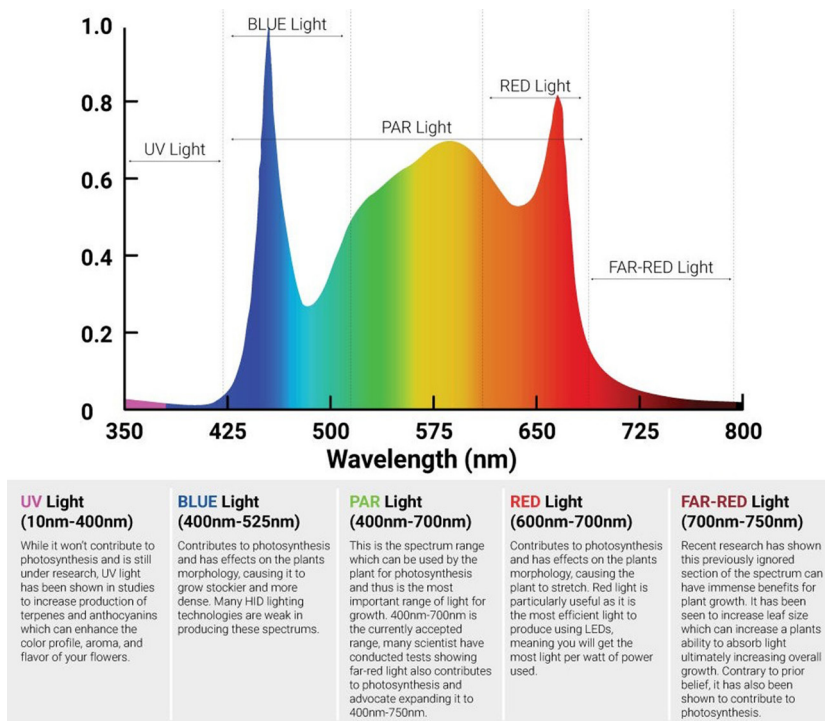


Fig.2. Wavelengths, spectrum of effective light in plant growth (Anonymous 2021c).

Sunlight is an environmental factor that affects the physiology and behavior of most organisms. In plants, especially during photosynthesis, light energy is converted into chemical energy stored as carbohydrates. Light is very effective in plant movements, reproduction, and germination. Adaptation to light conditions is very effective in the healthy growth of plants. In limited light conditions, the plant can optimize photosynthesis with the orientation of the leaf and chloroplast towards the light. In high light intensity and UV-B light conditions, plants prevent damage by removing the chloroplast and nucleus (nucleus) from light and synthesizing various pigments. Plants change their direction to light over a wide range of wavelengths, and the duration is called the photoperiod. It uses multiple photoreceptors to detect and respond to changes in spectral composition accurately. Unlike photoreceptors found in specialized organs in animals, plant photoreceptors are found throughout the plant. It has even been reported that some plant photoreceptors are also found in roots. Plants regulate different morphological and physiological events according to different

wavelengths of light. Photoreceptors in plants; It is classified as Phytochromes (phy), Cryptochromes (cry), Phototropins (phot), UVR8, ZTL/FKF1/LKP2 (Zeitlupe, Flavin-binding Kelch, LOV Kelch Proteins) (Galvão & Fankhauser 2015, Huché-Théliér *et al.* 2016).

Different light sources are the most influential environmental factor in plants' life, production, and productivity. The source of light in plant production is natural sunlight. With the developments in LED lighting technology, LED lighting comes into play at every stage of plant production. LED-based artificial light sources are widely seen in greenhouses, climate cabinets and rooms, tissue culture and biotechnology studies, and indoor plant factories. It has also been involved in plant production studies with the technological developments in space in recent years. Crop production in indoor areas using only LED light sources is of great interest. Plant production can only be realized with LED lighting technology. Plant growth can be accelerated by providing additional lighting in existing production areas, especially in greenhouses. Light sources and different wavelengths have different effects on plant physiology and plant growth. Light sources have a chance to be used not only for lighting but also in plant physiology research.

Another advantage of using LED lighting technology in greenhouses is that it provides an advantage in terms of carbon footprint. A carbon footprint measures the damage that human activities cause to the environment regarding the amount of produced greenhouse gases, measured in units of carbon dioxide. One of the ways to prevent carbon footprint damage is to use renewable energy sources for electricity and energy-saving LED lamps. It is of great importance to use LED lighting methods in greenhouses and focus on studies in this field, especially in countries where additional lighting is needed. Plants react differently to light than humans. Photosynthesis, which is effective in the growth of plants, is the light spectrum between 400-700 nm and is called PAR (photosynthetic active radiation). The wavelength of light is of great importance in plant production. Plants show different sensitivities according to varying colors of light. For this reason, the wavelength is as essential as the light sources used in plant production. Thus, the determination of light recipes is of great importance. Photomorphogenic responses in plants are affected by the spectral distribution of light. Maximum light absorption and photosynthesis by chlorophyll pigments occur in the blue and red regions of the visible light spectrum. Despite this, plants have special photoreceptors (phytochrome, cryptochrome, phototropin, UVR8) that regulate different physiological responses according to the wavelength of light (McCree 1972, Kopsell *et al.* 2013).

In the studies, it was determined that the anthocyanin concentration increased by 11% and 31% with the application of UV-A and blue supplementary light, the carotenoid content increased by 12% with the application of blue light, and the phenolic concentration increased by 6% with the application of red light. Additional FR light application does not cause a decrease in anthocyanin, carotenoid and chlorophyll content (Li and Kubota 2009). Carotenoid content in red leaf lettuces increases with the application of blue LED light. Polyphenol content and total antioxidant level are also higher in blue LED light applications than fluorescent applications (Johkan *et al.* 2010). LED lights have different effects on broccoli sprouts. As a result of the studies, short-term blue LED light application before harvest significantly increases  $\beta$ -carotene, violaxanthin, glucoraphanin, epiprogoitrin, aliphatic glucosinolate, basic micro and macro elements (Kopsell & Sams 2013).

In LED lighting, light with the properties required by the plant can be obtained in various frequency and wavelength ranges. Since the LED light is cold light, it can be used at any distance without the danger of burning the plants. This provides both design flexibility and space savings. Light is one of the critical factors in plant development. In the recent past, fluorescent and incandescent light were used for artificial lighting. However, scientific studies have shown that these lights have many disadvantages. Low lighting efficiency and high power usage are among these undesirable features. As a result of the research, LED (Lighting Emitting Diode) lights gave suitable results in plant growing. The wavelength and frequency of the light that plants generally need and accept for their morphological development are in a specific range. The effects of different colored LED lights on plants vary. The effect of LED light on plants depends on the color of the light, the exposure time of the plant to the light, the plant's growth period, the cultivar and the morphology of the plant. Thus, it becomes difficult to reach a consensus on the effects of the LED light. In this context, the need for special studies for different plants and conditions arises. However, some general judgments have been reached based on the data obtained from hundreds of studies in the analysis made with scientific studies today. According to the data obtained from 139 different experiments, it was seen that the plants using red LED light gave 54% and 172% more positive results in catalase and peroxisome production activities than the control group using white fluorescent light. Also, the plant length was found to be 63% shorter in the use of red LEDs. It was observed that the plants using blue LED light had lower leaf area (78%), dry root weight (69%), dry stem weight (37%), and stem length (64%) than the plants in the control group using white fluorescent light.

The total amount of antioxidants was found to be 68% higher in plants using blue LED light. According to the average of 101 experiments using red and blue LED light at a ratio of 1:1, it was seen that the dry weight of the plants using LED light was 161% more positive than the plants in the control group. The effect of red and blue LED light showed different effects on annual and seasonal plant species. For example, the increase in catalase production in seasonal crops was 77% higher than the increase in annual crops compared to the control group (Yuanchun *et al.* 2021).

The key advantages of LEDs include low power consumption, long lifetime and low radiant heat to the facility, and less heat in general. This allows the LEDs to be placed much closer to the plants. This results in a higher photon concentration leading to better photosynthetic productivity. At the same time, air conditioning costs in the grow room are reduced. Unlike FLs, which are very sensitive to ambient temperature and airflow, LEDs emit consistent light regardless of temperature conditions. Their construction allows for precise spectrum control, the use of monochromatic light that is impossible to achieve with conventional FLs. Finally, the disposal of LEDs is more environmentally friendly compared to FLs that contain mercury. The disadvantage of using LED is the high lighting unit price. However, high upfront costs can be repaid in the form of electricity savings. The cost of LEDs also keeps falling (Natalia Miller *et al.* 2019).

In addition to the light quality of the light sources, the position of the plants relative to their photosynthetic surface has a significant influence on crop productivity. The radiation energy captured by a surface from a point source is related to the inverse square of the distance between them. Therefore, reducing this distance will significantly affect the incident light level (Bickford & Dunn 1972).

LEDs can be operated at much lower energy levels to give the same event PPF on the photosynthetic surface. An essential issue for LEDs in horticulture concerns their economic viability. As with any emerging technology, the cost of LEDs for plant growth lighting will decrease over time as demand increases and research results become available (Massa *et al.* 2008). Thanks to the developing LED technologies, the properties such as dose, intensity, and wavelength of the produced light can be regulated very precisely. It is aimed to provide the optimum lighting environment needed for the development of different plants. In the early emergence of LED technologies, red and blue light were generally used for plant production. Today, red, blue light and their mixtures, as well as green, far-red, and UV (ultraviolet) light types, can be used together. Thanks



to this diversity, the wide range of rays offered by the sun can be imitated in a controlled manner. The use of UV rays, which are generally thought to harm plants, together with LED technology is a significant development. The use of low-dose UV light in light mixtures can provide positive morphological and metabolic developments in the plant. The developments in LED technologies enabled the use of UVA and UVB rays on plants and pioneered new studies. UV rays are examined in three categories: UVA (320-400nm wavelength), UVB (280-320nm wavelength), and UVC (100-280nm wavelength). All of the high-energy UVC rays from the sun are filtered by the ozone layer. Sun's 6% rays reaching our world consists of UVA and UVB. Plants have special photoreceptors that detect UVB rays. UVB rays are detected by the UVR8 receptor. When UVA rays are combined with blue light, the plant perceives them by stimulating phototropin and cryptochrome proteins. Phototropins and cryptochromes are proteins that are usually found throughout the leaves of the plant and that regulate the plant's response and growth according to the light environment. UVB rays can help the plant to maintain its own balance despite the negativities in its environment. The change of UVB rays in the biochemistry of the plant; has the potential to reduce undesirable changes and oxidative damage to DNA, proteins, and lipids. UVB rays applied at tolerable doses can cause the plant to reduce its biomass, develop smaller but thicker leaves, form shorter stature, modify the photosynthesis process, and produce less chlorophyll but more phenolic compounds. Phenolics are components that activate the antioxidant protective system of the plant and are of great importance for the human diet. They are also closely related to fruit and vegetable quality. Although the effects of UVA rays are still more controversial, there are results showing that they have an impact on the leaf area of the plant. It is effective in plant growth, antioxidant level, and phenolic production. Thanks to their higher wavelengths, UVA rays can reach deeper distances below the plants' surface. The use of UVA rays in plants has high potential, but more research is needed (Akvilè *et al.* 2019)

#### **4. Effects of LED Lights on Plants**

As we stated before, researchers have started looking for more resource-efficient ways to meet increasing food demand. Developments in LED technologies are encouraging. LED technology can lead to fully controlled indoor agricultural practice. Even urban agriculture has high potential, and it started to take off thanks to LED technologies. With the help of production in cities, significant

support can be provided to food production. Urban Agriculture has begun to be seen as an alternative approach with production in fully controlled closed areas (Eigenbrod & Gruda 2015).

Sunlight is essential for plants. However, access to sunlight in nature is affected by weather conditions. For this reason, access to the light source is not always at the desired level. Artificial light sources make it possible to produce high-yield plants in a controlled manner and independently of weather conditions. Until very recently, incandescent light sources and fluorescent light were used for artificial lighting. Studies have shown that these lights have many disadvantages, especially energy use. Low lighting efficiency, inability to obtain light in the desired wave range, and high power usage are among these undesirable features. As a result, researches use LED lights in plant growing has increased rapidly due to their essential advantages. The wavelength and frequency of the light that plants generally need for their morphological development are within specific ranges. Plant production with LED lighting at different wavelengths can be seen indoors (Figure 3).



Fig.3. Plant production studies with LED lighting at different wavelengths (Photo K.Demir)

Plant factories can produce fresh fruit and vegetables in all locations, from ocean liners to space stations.

Since they can produce fresh fruits and vegetables free from pests and pesticides in all weather conditions, they have increasing attention. The spectrum of photosynthetic action may vary in different seasons, at different times, in different plants, roots, stems, leaves, and fruits. Plants need chlorophyll-b and carotenoids as well as active chlorophyll-a in photosynthesis. The ideal light for plant growth should at least have an emissive spectrum covering these three pigments. In addition, ideal light can not exceed a certain level of photonic energy, otherwise it might damage chlorophyll. Organic light-emitting diodes (OLEDs), on the other hand, have very high spectrum adaptation flexibility. This is because it has a wide variety of emitters from red to violet and even infrared to ultraviolet (Jwo-Huei Jou *et al.* 2015).

In recent years, there have been rapid developments in the use of LED lighting technology in plant growth. Fully or additional lighting options have also emerged in plant cultivation in fully controlled indoor areas. LEDs used in greenhouses offer a different technology that has advantages over traditional lighting systems. In Figure 4, micro greenery production can be seen in an indoor LED-lighted environment.



Fig.4. Micro Greenery Production in Indoor Led Lighted Environment (Photo K.Demir)

## 5. LED and Its Characteristics

British radio engineer Henry Joseph Round discovered LED when he was working on radio waves, accidentally realizing that silicon carbide, which had a current flowing through it, radiated. LED is a specially designed solid

semiconductor diode, and it glows when current is passed through it. P-type (anode) and n-type (cathode) are combined with two different semiconductor LED chips, and current is sent from the anode to the cathode. The electron coming from the anode settles in a lower energy level orbit at the cathode and sends the energy difference out by radiating. The energy difference between them determines the color and wavelength of the radiation. Usually, the anode and cathode are seated in the lead body, and the LED chip is closed and protected by an epoxy capsule. (Dutta & Jatothu 2013, Ma *et al.* 2021). The diagram showing the general structure of the LED is shown below (Figure 5).

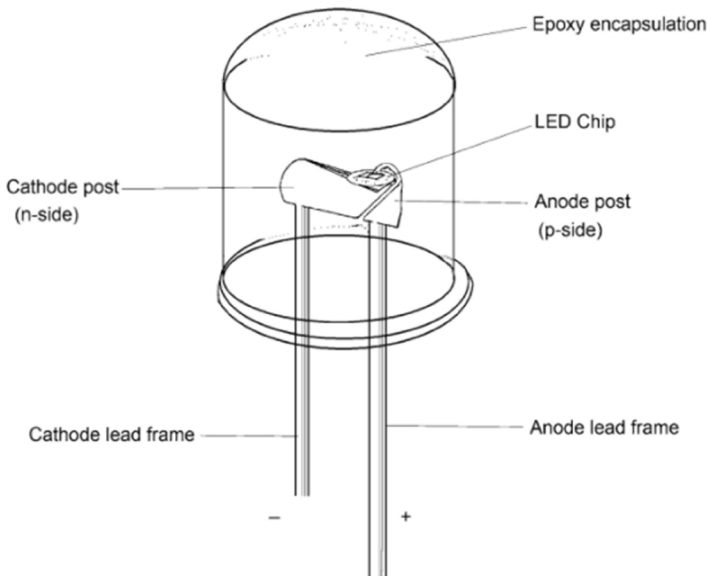


Fig.5. A simple LED mechanism (Dutta and Jatothu 2013).

LEDs can be connected in parallel or series. The same current passes through all the LEDs in a series connection, and the battery life is longer. The voltage required to light all the LEDs must be calculated in advance. At the same time, it should be examined whether the current will damage different LEDs. In a parallel connection, LEDs with different voltage needs cannot be used at the same time. In this case, either only one LED will light up, or the current flowing through the LEDs will damage the system due to different voltage requirements. LEDs with precisely the same characteristics can be paralleled quite successfully. Simple parallel and series-connected LED diagrams can be seen in the figure below (Figure 6).

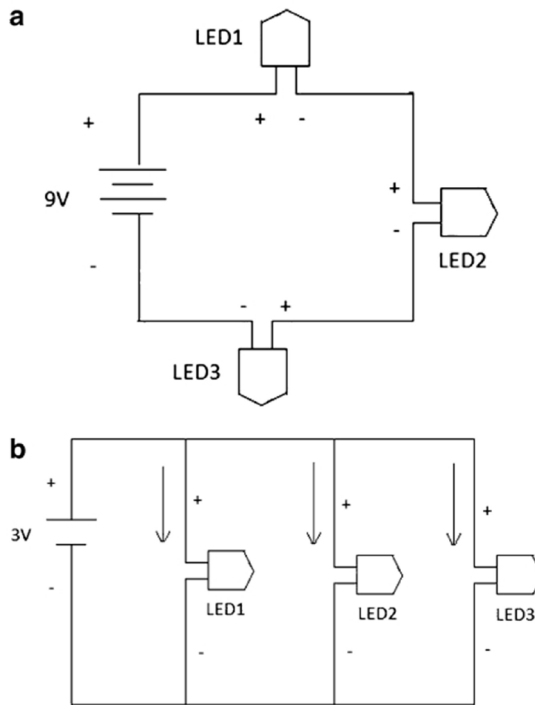


Figure 6. A-series and B-parallel connected LEDs (Dutta and Jatothu 2013).

Advantages of LED light sources: They can be used by connecting only to a battery by dint of their low energy consumption. Thanks to their low energy consumption, they are advantageous in commercial applications. A typical LED lamp has a lifespan of 25,000 to 100,000 hours. However, the life of a fluorescent lamp is around 15,000 hours. A large part of the spent energy is transferred to the outside as radiation, and meanwhile, heat production is relatively low. The color and wavelength of the produced light can be adjusted according to the plant's needs. It does not harm the plant due to its low heat emission. They can be used functionally even at tiny sizes (2-5 cm). The disadvantage of the LED light source is the high initial investment costs. If one LED breaks down, there is a more difficult replacement/repair process than conventional lighting systems (Dutta & Jatothu 2013). The characteristics of commercial LEDs and the materials used are given below in Figure 7.

**Table 1** Commercially available LEDs with colors, wavelength range, and material used

Wavelength range (nm)	Colour	Voltage drop ( $\Delta V$ )	Semiconductor material
<400	Ultraviolet	3.1–4.4	Aluminium nitride (AlN) Aluminium gallium nitride (AlGaN) Aluminium gallium indium nitride (AlGaInN)
400–450	Violet	2.8–4.0	Indium gallium nitride (InGaN)
450–500	Blue	2.5–3.7	Indium gallium nitride (InGaN) Silicon carbide (SiC)
500–570	Green	1.9–4.0	Gallium phosphide (GaP) Aluminium gallium indium phosphide (AlGaInP) Aluminium gallium phosphide (AlGaP)
570–590	Yellow	2.1–2.2	Gallium arsenide phosphide (GaAsP) Aluminium gallium indium phosphide (AlGaInP) Gallium phosphide (GaP)
590–610	Orange/amber	2.0–2.1	Gallium arsenide phosphide (GaAsP) Aluminium gallium indium phosphide (AlGaInP) Gallium phosphide (GaP)
610–760	Red	1.6–2.0	Aluminium gallium arsenide (AlGaAs) Gallium arsenide phosphide (GaAsP) Aluminium gallium indium phosphide (AlGaInP) Gallium phosphide (GaP)
>760	Infrared	<1.9	Gallium arsenide (GaAs) Aluminium gallium arsenide (AlGaAs)

Fig.7. Commercially available LEDs colors, wavelengths, and materials used (Dutta and Jatothu 2013).

## 6. Indoor Farming and Robotic Arm Use

Fully automatic vertical farming systems have a high commercial potential. Technology is in constant development. In the current situation, human intervention is required in the systems. Tracking and harvesting of products often have to be done manually. A system that does not require human intervention is proposed by suggesting robotic additions. ROBOTIQ brand 2-finger grip system handle is recommended for picking. The robot arm provides a gripping force between 20 N and 235 N. Together with the proposed camera system, this robot arm will be sufficient for many practical applications. At the same time, a harvesting and control algorithm has been proposed that will make the system fully automatic. This algorithm will ensure that all pots are checked first, and only then, matured products are collected. Details of the harvesting algorithm can be viewed in the figure below (Figure 8).



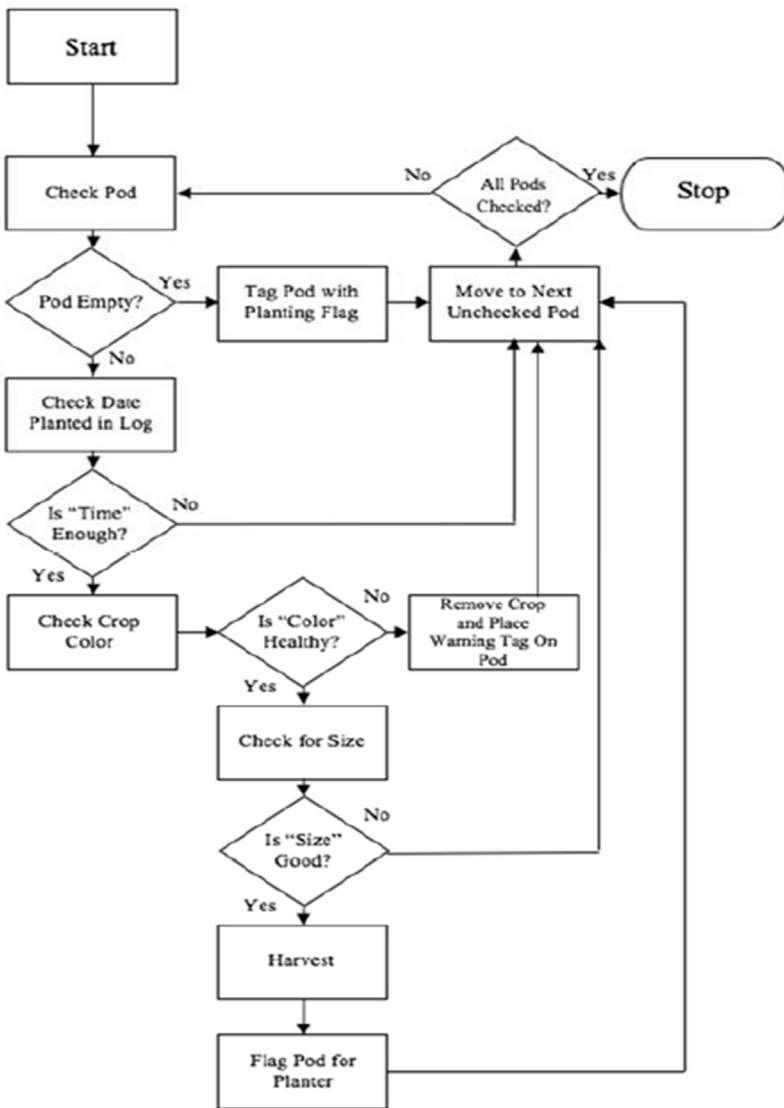


Fig.8. Harvest and control algorithm suggestions (Marchant & Tosunoglu 2017)

In this study, robotic arms, smart pots where plants are placed, sensors, communication technologies, and image processing technologies are used. Thus, a fully automatic greenhouse system has been introduced. Each system

is a whole in itself. However, they come together to form a fully automatic greenhouse system. The success of the system was discussed, and suggestions were made for future studies. Plants bearing green and red tomatoes with a height of about 1 meter were used to test the system. Saplings are placed in smart pots. There is a humidity sensor inside the pots, and the sensor sends data to the system every 10 seconds. Each plant has a unique IP number. Thus, the plant can be intervened by using this unique number while interacting with the system. The robot arm has a 2-step operating system. In the first step, a planner robot determines the priority order of the tasks that must be done at that time. For example, the planner can send the order to the robot arm to first irrigate the 2<sup>nd</sup> seedling and then the 3<sup>rd</sup> seedling to be harvested. The planner ranks these tasks according to cost-benefit analysis. In this cost-benefit analysis, parameters such as the distance that the robot arm must travel and the benefit of the operation to be performed are evaluated. Afterward, the implementing algorithm steps in and acts according to the priority of the given jobs. This implementing algorithm processes the data collected from the sensor and camera and calculates how much the robot arm should move in which direction. It performs this process via servo-motor and controllers. In the image processing part, the system processes the images from the camera, detects the product to be collected, and determines the path to be taken. Various difficulties were encountered in the image processing part. The different shapes and sizes of tomatoes prevent a standard recognition algorithm. It is difficult to distinguish between the leaves and stem of the seedling and the green tomatoes by color. In addition, various objects in the background negatively affect the operation of algorithms. Therefore, more than one image processing algorithm was used in this study. Data from 3 different algorithms were blended, and the most accurate result was tried to be achieved. In this way, 55% of tomatoes were detected correctly by the algorithm in general. While the detection of green tomatoes remained lower due to color mixing, red tomatoes were detected by the algorithm as high as 75%. Using these algorithms, detecting, locating, and picking a tomato by the robot arm was calculated as 28.3 seconds with an average deviation of 10 seconds per tomato (Correll *et al.* 2010, Marchant & Tosunoglu 2017).

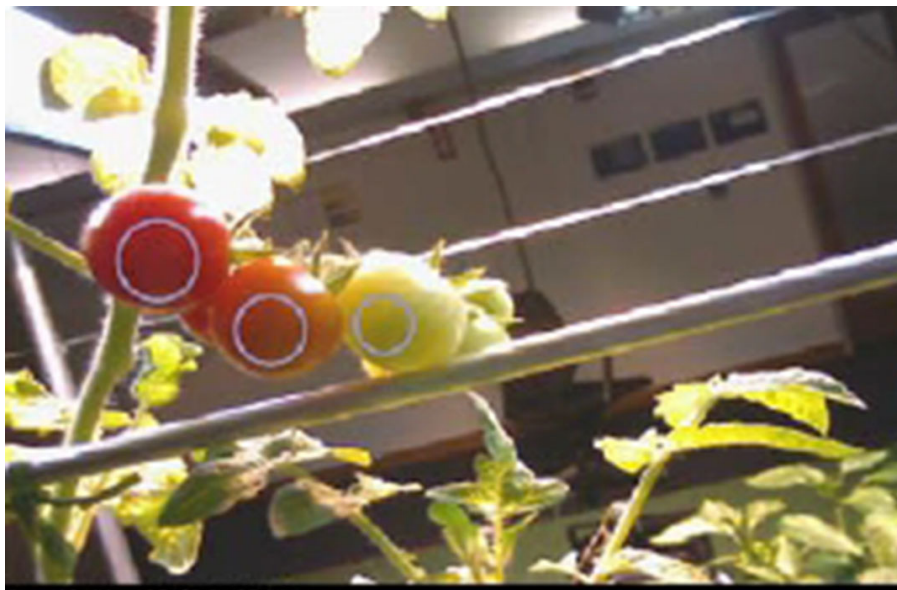


Fig.9. Red and green tomatoes detected by image processing algorithms (Correll *et al.* 2010).

The success rate of the robot arm in grasping the tomatoes was also found to be 75%. Reasons for failed attempts; It was determined that the errors in image processing caused the robot arm to misdirect and the seedling stem and leaves to prevent grasping. According to the data obtained as a result of the study; The advantages of placing plants in smart pots (for example, containers with humidity sensors) and assigning a separate number to each of the plants have been seen. The plants only informed the system when they needed it, and the system conveyed to the robot arms what needed to be done specifically for the plant. Thus, water and energy savings were achieved. The advantages of the simultaneous use of multiple algorithms for image processing were high. While a single algorithm could identify the shape (round, square), color, or edge of the image, it was necessary to use all algorithms together for the exact location of the tomatoes. Detection of the location of the green tomatoes was less successful due to the green stem and leaves of the seedling. Therefore, it is suggested to use additional algorithms for further studies. The fact that the robot arms have four degrees of freedom was not sufficient for grasping and harvesting the product from time to time. It is recommended to use robot arms with 6 degrees of freedom for further studies. Apart from that, the work is fully scalable. After the proposed improvements are made, the system can be used at larger scales (Correll *et al.* 2010, Valle & Kienzle 2020).

## Conclusion

Today, the importance of LED lighting and robotic arm technologies has been understood, especially in indoor areas and greenhouses. Studies have focused on these subjects in recent years. Energy efficiency aforementioned technologies is increasing rapidly. Such methods that will make significant contributions to plant production are being developed fast and the methods that can provide critical support to plant production and food supply.

## References

- Akvilè V; Giedrè S; Jurga M & Pavelas D (2019). Applications and advances in LEDs for horticulture and Production, ultraviolet LED technology for food applications, Academic Press, pp 35-65.
- Anonymous (2021a). FAOSTAT, <https://www.fao.org/faostat/en/#data>.
- Anonymous (2021b). TUIK, <https://data.tuik.gov.tr/Bulten/Index?p=Dunya-Nufus-Gunu-2021-37250>.
- Anonymous (2021c). <https://www.voltlighting.com/fl1-full-cycle-led-grow-light-120v>.
- Bickford E D & Dunn S (1972). Effects of lamp spectral emission. Kent State Univ. Press, Kent.
- Correll N; Arechiga N; Bolger A; Bollini M; Charrow B; Clayton A; Dominguez F; Donahue K; Dyar S; Johnson L; Liu H; Patrikalakis A; Robertson T; Smith J; Soltero D; Tanner M; White L & Rus D (2010). Indoor robot gardening: design and implementation. *Intelligent Service Robotics* 3(4):219-232.
- Dutta Gupta S & Jatothu B (2013). Fundamentals and applications of light-emitting diodes (LEDs) in in vitro plant growth and morphogenesis. *Plant Biotechnology Reports* 7(3):211-220.
- Eigenbrod C & Gruda N (2015). Urban vegetable for food security in cities. A review. *Agronomy for Sustainable Development*, 35(2):483-498.
- Erim G (1999). Temel sanat eğitiminde renk algılamaları. Sanatta Yeterlilik Tezi. Marmara Üniversitesi, 125p, İstanbul.
- Galvão V C & Fankhauser C (2015). Sensing the light environment in plants: photoreceptors and early signaling steps. *Current Opinion in Neurobiology* 34:46-53.
- Godfray H C J; Beddington J R; Crute I R; Haddad L; Lawrence D; Muir J F & Toulmin C (2010). Food security: the challenge of feeding 9 billion people. *Science* 327: 812-818.

- Huché-Théliér L; Crespel L; Le Gourrierc J; Morel P; Sakr S & Leduc N (2016). Light signaling and plant responses to blue and UV radiations-Perspectives for applications in horticulture. *Environmental and Experimental Botany* 121:22-38.
- Johkan M; Shoji K; Goto F; Hashida S N & Yoshihara T (2010). Blue light-emitting diode light irradiation of seedlings improves seedling quality and growth after transplanting in red leaf lettuce. *HortScience* 45(12): 1809-1814.
- Jwo-Huei J; Ching-Chiao L; Tsung-Han L; Chieh-Ju Li; Shiang-Hau P; Fu-Chin Y; Justin Thomas K R; Dhirendra K; Yun C & Ban-Dar H (2015). Plant growth absorption spectrum mimicking light sources. *Materials* 8:5265-5275.
- Koç C; Vatandaş M & Koç A B (2009). LED aydınlatma teknolojisi ve tarımda kullanımı. 25. Tarımsal Mekanizasyon Ulusal Kongresi, 153-158.
- Kopsell D A & Sams C E (2013). Increases in shoot tissue pigments, glucosinolates, and mineral elements in sprouting broccoli after exposure to short-duration blue light from light emitting diodes. *Journal of American Society of Horticultural Science* 138(1):31-37.
- Li Q & Kubota C (2009). Effects of supplemental light quality on growth and phytochemicals of baby leaf lettuce. *Environmental and Experimental Botany* 67(1):59-64.
- Ma Y; Xu A & Cheng Z M (2021). Effects of light emitting diode lights on plant growth, development and traits a meta-analysis. *Horticultural Plant Journal* 7(6):552-564.
- Marchant W & Tosunoglu S (2017). Robotic implementation to automate a vertical farm system. 30st Florida Conference on Recent Advances in Robotics. May 11-12, 2017, Florida Atlantic University, Boca Raton, Florida.
- Massa G D; Kim H H; Wheeler R M & Mitchell C A (2008). Plant productivity in response to LED lighting. *HortScience* 43(7):1951-1956.
- McCree K J (1972). Test of current definitions of photosynthetically active radiation against leaf photosynthesis data. *Agricultural Meteorology* 10:443-453.
- Miler N; Kulus D; Woźny A; Rymarz D; Hajzer M; Wierzbowski K & Szeffs L (2019). Application of wide-spectrum light-emitting diodes in micropropagation of popular ornamental plant species: a study on plant quality and cost reduction. *In Vitro Cellular & Developmental Biology-Plant* 55(1):99-108.

- Schmitz C; van Meijl H; Kyle P; Nelson G C; Fujimori S; Gurgel A & Valin H (2014). Land-use change trajectories up to 2050: insights from a global agro-economic model comparison. *Agricultural Economics* 45(1): 69-84.
- Valle S S & Kienzle J (2020). AGRICULTURE 4.0 - Agricultural robotics and automated equipment for sustainable crop production. *Integrated Crop Management* 24.
- Yuanchun M; An X,; Zong-Ming C (2021) Effects of light emitting diode lights on plant growth, development and traits. *Horticultural Plant Journal*, 7(6): 552-564.






## CHAPTER 6

# EFFECTS OF COLCHICINE ON *IN VITRO* REGENERATION AND PLOIDY LEVEL IN GRAPEVINE (*VITIS VINIFERA* L.)

Elif Ceren PEHLİVAN<sup>1</sup> & Birhan KUNTER<sup>2</sup>

<sup>1</sup>(Dr.), Tekirdağ Namık Kemal University, Faculty of Agriculture,  
Department of Agricultural Biotechnology, Tekirdağ, Türkiye,  
e-mail: eckalinkara@nku.edu.tr

 0000-0001-5632-2955

<sup>2</sup>(Prof. Dr.), Ankara University, Faculty of Agriculture,  
Department of Horticulture, Ankara, Türkiye,  
e-mail: marasali@agri.ankara.edu.tr

 0000-0001-7112-1908

### 1. Introduction

Today, world viticulture has been developed depending on a few species in the *Vitis* genus. *Vitis vinifera* L. is undoubtedly the dominant species in the concept of grape varieties and *Vitis vinifera* L. is the sole native species of European viticulture, serves new genetic breakthroughs for ploidy breeding, mainly by including consumable varieties of *Vitis labrusca* (Chen *et al.* 2014, Mitani *et al.* 2014). Grapevines are vegetatively propagated plants that have the capacity to accumulate somatic mutations. Therefore, many grapevine cultivars derived clonally have been propagated from differentiated bud sources (Aradhya *et al.* 2003; Keskin & Kunter 2009; Keskin & Kunter 2010; Kunter & Değirmenci Karataş 2011; Vezzuli *et al.* 2012; Cruzan *et al.* 2020; Kuliyevev 2020). Mutations in somatic cells can arise at diploid or polyploid levels in a grapevine population. There are many identified bud sports in well-known cultivars such as ‘Pinot Noir’, ‘Sultani’, ‘Muscat of Alexandria’ variants.

Since somatic variation contributes to reproducing new grape varieties and polyploid variants show outstanding viticultural properties such as seedlessness and large berries, special interest has been given to polyploidy in grape breeding studies. Therefore, mutagenic treatments have been adapted to the studies to induce somatic variation capability and frequency in a cultivar. After the first thought of induced mutagenesis on polyploid grape breeding, economically valuable polyploid grape varieties such as 4x 'Kyoho', 3x 'King Dela' and 3x 'Mirei' have been developed (Yun et al. 2008). The seedless characteristics of the triploid grapes that have been developed have opened a new way to obtain large and seedless grape varieties and breeding studies. Therefore, polyploid individuals are important for parents of hybridization studies as well as being direct commercial varieties (Xu et al. 2014).

Mutagenic treatments have been adapted to the studies to induce somatic variation capability and frequency in a cultivar. Both successful and negative results have been reported based on the effect of mutagen, the choice of the treated organ, or treatment techniques *in vivo* and *in vitro* conditions.

Colchicine is the well-known chemical mutagen used to induce genome duplication artificially in plants. It is a powerful poison in alkaloid nature, derived from the roots of meadow saffron (*Colchicum autumnale* L.) and a colorless substance. Colchicine prevents the formation of the spindle apparatus in the metaphase stage of mitosis in the cells of the applied tissues. In this way, it prevents the replicated chromosomes from being pulled out to the poles during the anaphase stage, allowing the chromosome number to be doubled (Manzoor et al. 2019).

Successful chromosome doubling protocols of colchicine have been reported in some important genus such as *Lilium*, *Citrus* (Zeng et al. 2006), *Nepenthaceae* (Fong 2008), and *Passifloraceae* (Rego et al. 2011). Colchicine treatment has also been used as a polyploidization agent either *in situ* or *in vitro* conditions with variable results regarding the application dose and method, incubation time, type of explant in grapevines (Yang et al. 2006; Kuliyevev 2020). Moreover, the response of the genotype towards colchicine treatment plays a major role in the efficiency of polyploidization.

In this chapter, it was aimed to evaluate the effects of colchicine on explant regeneration and the ploidy variation in the derived individuals via *in vitro* culture in two grape cultivars.

## 2. Material and Method

### 2.1. Plant material and explant preparation

'Sultani' and 'Uslu' *Vitis vinifera* L. cultivars ( $2n = 2x = 38$ ) were the main plant materials of the study. First, cuttings of one-year-old canes of 'Sultani' and 'Uslu' were forced to give shoots under *in vivo* controlled conditions in 16/8-hour light/dark photoperiod, in an air conditioning room with 24°C temperature and 70-80% humidity. Then actively growing shoots were used to prepare the shoot tip and single-node microcutting explants (Figure 1).



Fig.1. Explant types. Shoot tip (left), Single-node microcutting (right)

Shoot tips and single-node microcuttings were surface sterilized with 10.0 % (v/v) Actijen for 10 min and 20 % (v/v) sodium hypochlorite for 15 min, orderly, and subsequently rinsed 3 x 5 minutes with autoclaved distilled water. After surface sterilization was completed, the explants were prepared for cultivation in a liquid MS nutrient medium containing different doses of colchicine. MS nutrient medium (Murashige & Skoog 1962) was used as a basal culture medium in this study. The medium was adjusted to  $\text{pH } 5.7 \pm 1$  before sterilization. Cultures were sterilized under  $1.1 \text{ kg cm}^2$  pressure at 121°C for 20 minutes in an autoclave. Incubation conditions of the cultures were  $24 \pm 2^\circ\text{C}$  under 16 hours and 2000-2500 lux photoperiod in a climate cabinet (Daihan Scientific, Wisecube).

### 2.2. Colchicine treatment

Colchicine doses were determined according to the doses applied to grapevine shoot tip and single-node microcutting explants in a liquid nutrient medium in

the previous literature (Notsuka *et al.* 2000; Chang *et al.* 2014; Sinski *et al.* 2014; Xie *et al.* 2015). In this study, 1000, 1250, and 1500  $\mu\text{M}$  concentrations of colchicine were used. Colchicine (Sigma-Aldrich) stock solution was prepared in distilled water at a dose of 100 mM and stored at  $-20^{\circ}\text{C}$ . The working solution was diluted to the desired volume with sterile distilled water using a sterile syringe filter (Millex-GS) and a commercial 10 ml syringe (SET / inject). Colchicine treatment was carried out with three different doses (1000, 1250, 1500  $\mu\text{M}$ ) by adding the volume of 50 ml in each 100 ml erlenmeyer flask which contains shoot tip and single-node microcutting explants into the liquid MS medium. The explants were incubated in a colchicine-containing nutrient medium at  $24^{\circ}\text{C}$  at 100 rpm on an orbital shaker for 24 and 48 hours in darkroom conditions until transferred to a solid MS nutrient colchicine-free medium.

### 2.3. *Survival and regeneration rate*

After colchicine treatment, explants were elutriated in distilled water  $3 \times 5$  minutes for removing residue of colchicine and transferred to MS shoot regeneration nutrient medium containing 1 mg  $\text{L}^{-1}$  BAP solidified with 6.5% agar. Approximately on the 30<sup>th</sup> day of culture, the survival rates, expressed as the number of healthy plantlets, in the shoot regeneration medium were determined. In order to ensure the sustainability of the shoots, developed from shoot tip and single-node micro-cutting explants, were transferred in a shoot propagation medium containing 1 mg  $\text{L}^{-1}$  BAP+0.1 mg  $\text{L}^{-1}$  IBA. 30 days after the survival rate was determined. For this aim, the number of healthy shoots developed per explant was counted to determine the shoot regeneration rate.

### 2.4. *Ploidy level analysis*

Flow cytometry was used to determine the ploidy level of the regenerated individuals. Leaf samples were used to determine nuclear DNA content. CyStain UV Precise P kit (SYSMEX) was used in the analysis. 15  $\mu\text{g}$  fresh leaf tissues taken from the young parts of the grapevines that have become 4-5 leaves and 10  $\mu\text{g}$  from the tomato plant under *in vitro* conditions were chopped into small pieces in a petri dish with a razor blade with 0.5 or 0.6 ml of nuclei isolation buffer. 1 ml of a stock solution (20 ml  $\text{MgSO}_4$  buffer, 20 mg Dithiothreitol, 500  $\mu\text{l}$  PI stock, 550  $\mu\text{l}$  TritonX-100) was added to the petri dish and left in this solution for 5 minutes. Then, 2.4 ml of 5  $\mu\text{M}$  DAPI staining solution (4',6-diamidino-2-phenylindole) was added to the crushed nuclei and kept in this solution for 5 minutes. The suspended nuclei were transferred to micro-centrifuge tubes and filtered with 30-33  $\mu\text{m}$  filters. The pellet was dissolved in 400  $\mu\text{l}$  solution B

(5 ml solution A, 10  $\mu$ l RNase and DNase free). Samples were prepared as a result of isolation analyzed by flow cytometry. Flow cytometry analyses were performed according to the method of Tuna & Cabi (2014). The response of the total DNA of single nuclei to fluorescence was analyzed by PA flow cytometry (Partec 06-5-4003). The DNA content of 5.000 nuclei was examined in each sample (Glowacka *et al.* 2010). The amount of DNA in a plant cell was indicated by the letter ‘C’ in picograms. The C value refers to the haploid genome, and the 2C value refers to the DNA amount of the diploid somatic genome. The C values determined for the nuclear DNA contents of the plants were indicated in picograms and converted into nucleotide base pairs (1 pg = 980 Mbp) (Tuna & Cabi 2014). Ploidy levels were evaluated by comparing the peak formed as a result of flow cytometry reading of each sample taken as a result of *in vitro* experiments with these standard (tomato) peaks.

### 2.5. Statistical analysis

All experiments in the study were performed in three replicates. The data of the trials were subjected to One way or Two-way ANOVA (Factorial analysis of variance). LSD (least significant difference test) was used in the statistical evaluations to determine the differences between the averages, and the statistical significance level was considered  $p < 0.05$  and  $p < 0.01$ . JMP (ver.14) computer package program was used for statistical evaluations.

## 3. Results

In this study, the explant responses to colchicine treatments were evaluated using survival and the regeneration rate of the explants depending on the cultivars (Figure 2).

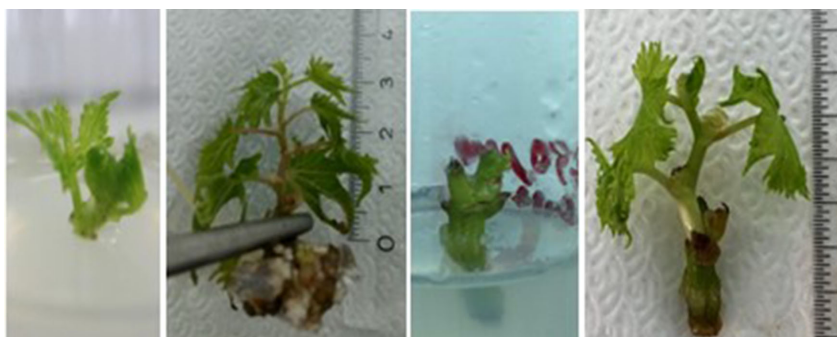


Fig.2. *In vitro* development of plantlets from shoot tip and single-node microcutting explants



### 3.1. *Effect of colchicine treatments on explant survival rate*

In ‘Sultani’, non-significant interaction was determined between colchicine doses × incubation times in terms of the explant survival rate in both explants.

According to the colchicine doses, the survival rates of shoot tip explants varied between 31.67% (1500 µM colchicine dose at 48 hours)-87.88% (control group) and among the single-node microcutting explants varied between 65.95% (1000 µM colchicine dose at 48 hours)-86.10% (control group). The highest survival rate was found in the control group after 24-48 hours of colchicine treatment in both explants. The highest survival rates were 75.00% in the shoot tip explants (1000 µM colchicine dose at 24 hours), and 79.63% in the single-node microcutting explants (1250 µM colchicine dose at 24 hours). The lowest survival rates were 31.67% in shoot tip explants (1500 µM colchicine dose at 48 hours) and 65.95% in the single-node microcutting explants (1000 µM colchicine dose at 48 hours). There was a decrease in survival rate (68.33%) depending on the increased incubation time (48 hours) in both explant types. There was a dramatic decrease in survival rate in the shoot tip explant as the colchicine dose increased, while a slight decrease was observed in the single-node microcutting explant (Table 1).

In ‘Sultani’, a statistically significant interaction between colchicine dose × incubation times was found for the regeneration rate in shoot tip explant. Still, the interaction was not determined in the single-node microcutting explant. The highest regeneration rate was found in the control group after 24-48 hours of colchicine treatment in both explant types. The regeneration rates were 55.11% and 11.11% in shoot tip explants and 53.33% and 50.00% in single-node microcutting explants, respectively, at 1000 and 1250 µM colchicine doses applied during the 24 hour incubation time. Regeneration was not observed in both explants at the highest dose of 1500 µM colchicine in 24 hours. The regeneration rates at 1000, 1250, and 1500 µM colchicine doses at the 48 hour incubation time were determined as 50.00%, 27.78%, and 22.22%, respectively, in the shoot tip explants. 48 hour incubation time at 1000 and 1250 µM colchicine doses showed as 49.28% and 51.00% regeneration rate in single-node microcutting explant, respectively. Regeneration did not occur in single-node microcutting explant at the highest dose of 1500 µM colchicine in 48 hours of incubation (Table 1).

In ‘Uslu’, a statistically important interaction was determined between for the explant survival rate in both explant types.

According to the doses, the survival rate varied between 21.67% (1500 µM colchicine dose at 48 hours)-71.85% (control group) in the shoot tip explant,

and 38.10% (1500  $\mu$ M colchicine dose at 48 hours)-90.48% (control group) in the single-node microcutting explant. Likewise to 'Sultani', the highest survival rate was found in the control group after 24-48 hours of colchicine treatment in both explants of 'Uslu'. The highest survival rate was 59.23% and 76.67%, respectively, in shoot tip and single-node microcutting explant at the 24 hours incubation time of the 1000  $\mu$ M colchicine dose.

Depending on the incubation time, there was a decrease in the survival rate for both explants at the 48 hour incubation time. The survival rate was determined as 50.00% and 58.33%, respectively, in applying 1250  $\mu$ M colchicine at the 24 hour incubation time in the shoot tip and single node microcutting explant. The survival rate was decreased by increasing incubation time. The survival rate relative to the explant number at the 48 hour incubation time was determined as 25.00% for shoot tip and 44.82% for single-node microcutting. In the highest dose of 1500  $\mu$ M colchicine, the survival rates of explants were determined as 25.00% and 50.00% at the 24 hour incubation time, and 21.67% and 38.10% at the 48 hour incubation time, in the orderly shoot tip and single-node microcutting explants. The survival rate, relative to the explant number, at the 48 hour incubation time was determined to be 25.00% for shoot tip and 44.82% for single-node microcutting.

Difference in the survival rate between the 24 and 48 hour incubation times was statistically significant ( $p < 0.01$ ). As the colchicine dose increased, the survival rate decreased (Table 2).

Colchicine dose $\times$ incubation time interaction was found statistically significant ( $p < 0.05$ ) on regeneration rate of 'Uslu'.

According to the doses, the regeneration rate varied between 00.00% (1500  $\mu$ M colchicine dose at 48 hours) - 65.92% (control group) in the shoot tip explant and 00.00% (1500  $\mu$ M colchicine dose at 48 hours) - 48.41% (control group) in the single-node microcutting explant. The highest regeneration rate was found in the control group after 24-48 hours of colchicine treatment in both explant types. Among the treatments, 1000 and 1250  $\mu$ M colchicine doses at 24 hours of incubation showed regeneration in the explants. The regeneration rates were 25.00% and 10.00% in shoot tip explants whereas 48.33% and 40.00% in single-node microcutting explants. Regeneration was not obtained in shoot tip explant at 1500  $\mu$ M dose at the 24 hours. It was recorded 17.71% in single-node microcutting explant. At the dose of 1000  $\mu$ M colchicine at the 48-hour incubation, the regeneration rate was determined as 22.22% and 31.10% in shoot tip and single-node microcutting explant, respectively. Although regeneration was not obtained in shoot tip explant at 1250  $\mu$ M dose in 48 hours,

it was recorded as 26.20% in single-node microcutting explant. Regeneration was not observed in both explants, at 1500  $\mu\text{M}$  colchicine dose for 48 hours. Even though there was a non-significant difference between incubation times regarding regeneration rate, 0.01 difference was found between doses (Table 2).

Table 1. Explant survival and regeneration rates in 'Sultani'

Colchicine treatment		Shoot tip		Single-node microcutting	
Concn. ( $\mu\text{M}$ )	Inc. (h)	Survival rate (%)	Reg. rate (%)	Survival rate (%)	Reg. rate (%)
Control		87.88	94.63 a	86.10 a	56.67
1000	24	75.00	55.55 b	76.67 a	53.33
	48	58.34	50.00 b	65.95 c	49.28
1250	24	68.23	11.11 d	79.63 a	50.00
	48	46.67	27.78 c	68.33 bc	51.00
1500	24	55.00	00.00 e	75.00 bc	00.00
	48	31.67	22.22 c	66.67 bc	00.00
LSD		ns	7.28*	ns	ns

\* significant at the %5 level, ns: non-significant The difference between the means was expressed with different letters in the same column (Concn.: Concentration, Inc.: Incubation time, Reg.rate: Regeneration rate)

Table 2. Explant survival and regeneration rates in 'Uslu'

Colchicine treatment		Shoot tip		Single-node microcutting	
Concn. ( $\mu\text{M}$ )	Inc. (h)	Survival rate (%)	Reg. rate (%)	Survival rate (%)	Reg. rate (%)
Control		71.85 a	65.92 a	90.48 a	48.41 a
	24	59.23 ab	25.00 b	76.67 a	48.33 a
1000	48	25.00 c	22.22 b	44.44 c	31.10 c
	24	50.00 b	10.00 c	58.33 b	40.00 b
1250	48	25.00 c	00.00 d	44.82 bc	26.20 c
	24	25.00 c	00.00 d	50.00 bc	17.78 d
1500	48	21.67 c	00.00 d	38.10 c	00.00 e
LSD		13.27**	6.91*	13.89*	7.80*

\*\* significant at the %1 level, \* significant at the %5 level

The difference between the means was expressed with different letters in the same column (Concn.: Concentration, Inc.: Incubation time, Reg.rate: Regeneration rate)

### 3.2. Ploidy level analysis on regenerated plantlets

In this study, the final aim was to establish an efficient chromosome doubling protocol by using colchicine *in vitro* on the studied cultivars. Therefore the effect of colchicine on ploidy level was evaluated by nuclear DNA content.

DNA content of the control plantlets of ‘Sultani’ was found 1.32 pg in both explant types. As compared to control plants, DNA contents varied between 1.12-1.20 pg in shoot tip and 1.07-1.49 pg in single-node plantlets. The highest amount of nuclear DNA content was determined in the plantlets obtained from 1000  $\mu\text{M}$  colchicine and 24 or 48 hours incubation treatments in ‘Sultani’. Statistical analyzes showed significant differences were not found in single node micro-cutting and shoot tip explants in terms of dose  $\times$  incubation time. In this study, polyploidy genotypes could not be produced in ‘Sultani’ cv. by the methods followed.

Table 3. Nuclear DNA content *in vitro* plantlets derived from shoot tip and single-node microcutting of the ‘Sultani’ cultivar

Concentration ( $\mu\text{M}$ )	Incubation time (h)	Shoot tip	Single-node microcutting
Control		1.32 a	1.32 b
1000	24	1.12 c	1.11 c
	48	1.20 b	1.49 a
1250	24	nd	1.12 c
	48	nd	nd
1500	24	nd	1.07 c
	48	nd	nd
LSD		ns	ns

ns: non-significant, nd: non-determined

The difference between the means was expressed with different letters in the same column

The nuclear DNA content in the control plantlets of ‘Uslu’ was found 1.32 pg. Results in the *in vitro* derived plantlets showed low or non-determined DNA content than the control ones in each colchicine concentration and incubation time. The nuclear DNA contents varied between 1.13-1.15 pg in the single node microcutting explant in the application of colchicine for 24-48 hours between 1.13-1.15 pg in the single-node microcutting explants in the applications of colchicine. Besides, in shoot tip plantlets, only the treatment of 1000  $\mu\text{M}$

colchicine dose at 48 hours, the average amount of nuclear DNA content in the analyzed samples were found 1.10 pg.

In the study, we are unable to reach an informative change in 'Uslu' (Table 4). Therefore we declare that among the obtained variants in 'Uslu' cv., ploidy level was not identified by flow cytometry.

Table 4. Nuclear DNA content *in vitro* plantlets derived from shoot tip and single-node microcutting of the 'Uslu' cultivar

Concentration (μM)	Incubation time (h)	Shoot tip	Single-node microcutting
Control		1.26 a	1.26 a
1000	24	nd	1.17 b
	48	1.10 b	1.13 b
1250	24	nd	1.17 b
	48	nd	1.15 b
1500	24	nd	nd
	48	nd	nd
LSD		ns	ns

ns : non-significant, nd: non-determined

The difference between the means was expressed with different letters in the same column

#### 4. Discussion and Conclusion

*In vitro* regeneration systems offer methodological benefits in artificial induction of polyploidy in plant breeding studies. For *in vitro* polyploidization, primarily, it is required to choose the correct tissue culture technique and explant to provide maximum success (Petersen *et al.* 2003). Explant-based characteristics, such as tissue size or cell permeability, are important to transport the antimetabolic agent into the meristem layers (Allum *et al.* 2007). It was reported that applying the antimetabolic agent to the same plant species or even to different tissues of the same plant gives different results (Aihong *et al.* 2005; Sinski *et al.* 2014; Blasco *et al.* 2015; Xie *et al.* 2015). In the grapevine, organogenesis methods mainly, shoot tip culture, node culture, axillary meristem culture, were used for *in vitro* chromosome doubling. For this purpose, shoot tip (Sinski *et al.* 2014), axillary meristem (Notsuka *et al.* 2000), etc. used as explants. On the other hand, solid, semi-solid, or liquid media use compatible with the tissue is necessary for successful development.

In the studies of chromosome doubling in grapevine via tissue culture techniques, type and component of culture media (Guo *et al.* 2011; Sinski *et al.* 2014), incubation time of the using mutagens (Allum *et al.* 2007; Escandon *et al.* 2007; Glowacka *et al.* 2010; Chen *et al.* 2014) and dose (Xie *et al.* 2015) are the main factors that affect the ploidy level. In the study conducted by Notsuka *et al.* (2000) regarding obtaining tetraploid plantlets in grapevine by *in vitro* organogenesis, the highest rate of tetraploid individuals was obtained from colchicine treatment at a dose of 0.2% for two days incubation.

In the study of Acanda *et al.* (2015), four different doses of colchicine (0, 0.1, 0.2, and 0.4%) were applied to embryogenic cell aggregates in suspension culture for 24 hours in the 'Mencia' grape variety (*V. vinifera*). Results showed that the most effective colchicine dose was 0.2%, as in Notsuka *et al.* (2000), and 25% of tetraploid plants were reached at this dose. In the study of Ekbiç and Tangolar (2016), in 'Trakya İlkeren' and 'Flame Seedless' varieties, colchicine was applied at 0.5%, 0.75, and 1 dose for 1, 3, and 5 days on shoot tip explants *in vivo*. It has been reported that 1% colchicine doses in 'Trakya İlkeren' variety, 0.75% and 1% in 'Flame Seedless' variety cause toxicity and drying for shoot tip explants. In the study of Sinski *et al.* (2014), the best dose × time for viability was obtained from 48 hours of applying 250 µM colchicine dose in shoot tip. In our study, similar to the studies mentioned above, the higher vitality was obtained in 24-hour application in 'Sultani' and 'Uslu' cvs. In the study of Xie *et al.* (2015), 48 and 72 hours of colchicine dose application to shoot tip explants induced high levels of tetraploidy (31.41% - 35.08%), however it was also stated that these treatments had been caused damage on shoot tip explants.

Carvalho *et al.* (2005) emphasized that the application of colchicine delayed germination in the cotyledon nodes of Arnatto plant and degeneration of the hypocotyl during regeneration. Xie *et al.* (2015) emphasized that chromosome doubling studies significantly delayed growth and development in grapevine explants. After the application on shoot tips, the first regeneration took place after four weeks and within three weeks in control. In the control group emerging of embryogenic calluses was delayed for another 3-4 weeks, and regeneration occurred after about two months. In the production of embryogenic callus from the anther, this period was five months. Sinski *et al.* (2014) reported that colchicine treatment was not differently effective on shoot tip regeneration between the grape varieties 'Crimson Seedless' and 'BRS Clara' in liquid medium C2D4B. Regeneration rate of shoot tips were 9.56% and 11.55% respectively. In our study, it was determined that the regeneration

rates were found to be higher in colchicine treatment in liquid nutrient medium in 'Sultani' and 'Uslu' varieties.

It has been reported in many studies that the reason for the difference in colchicine applications on plant regeneration is the result of the defense mechanisms of plant tissue and cell (Nadler *et al.* 2012). *In vitro* regeneration systems via organogenesis have provided greater successful chromosome doubling protocols. Sinski *et al.* (2014) emphasized that shoot tip explants are suitable for transforming into the polyploid structure for *Vitis* sp. Also, Martinelli and Gribaudo (2009) reported that the genotype is a determining factor in the grapevine for ploidy induction.

It was emphasized that similar rates of tetraploids were achieved in applications performed in shoot tip and embryogenic callus. Using a  $625 \mu\text{M} \times 72$  hour colchicine dose in shoot tip explants to reach tetraploid plantlets would provide an advantage in terms of time (Xie *et al.* 2015).

Many studies showed that a higher viability rate was generally derived in low dose  $\times$  short application time. However, in terms of tetraploid plant formation, it exhibits a low ratio on the contrary (Zhang *et al.* 2008).

Leal *et al.* (2006) obtained shoots from somatic embryos developed by anther induction in two different clones (VS1508 and VS1510) of *Vitis vinifera* L. 'Viosinho' cv. When the seed DNA contents and ploidy levels of *V. vinifera* varieties were compared, it was reported that there was no statistically significant difference, and the DNA content range was found 1.16 and 2.35 pg/2C. The seed DNA content range revealed in our study is similar to the DNA content range in Leal *et al.* (2006). In our study, the ploidy level of the regenerated plants in both cultivars was the same as that of the mother plant. However, some differences were detected in DNA contents; the flow cytometry results verified the genetic stability at the diploid level. At this point, the conclusion of Prado *et al.* (2010), which is about in the grapevine the effect of cytosolic phenolics, such as tannic acid, negatively influence flow cytometry results, could be an explanation for our results.

Choosing the shoot tip for mutagen application may be recommended since the possibility of being affected by mutagen is reduced because single-node microcutting is a larger explant. According to the results of our study, we conclude that shoot tip culture was more successful for colchicine applications than the single node culture. The reason for this success might be related to the shoot tip explant being a smaller tissue. It was determined that the single-node microcutting explants were more resistant to long incubation time in colchicine treatment compared to the shoot tip. Compared to the shoot tips, the single-node



microcutting explants were determined resistant to colchicine application for 24-48 hours. It is stated that applications with doses higher than 1250  $\mu$ M might not be advised for future studies; however, a lower dose of colchicine for an incubation period of longer than 48 hours seemed to be recommendable.

The regeneration rate has been changed according to the cultivar rather than the explant type. The best regeneration at the lowest dose was obtained from both explants of the 'Sultani' cv. The higher dose of colchicine application usually showed better regeneration in 'Sultani' grape cultivar than 'Uslu' cv.

As a result of this study, it was concluded that the effects of the explant, antimetabolic agent, dosage, incubation time, and application method could be evaluated depending on the variety. When the literature was examined together with our study, it was suggested that only a protocol specific to the variety and explants would provide a tool for inducing variations.

In addition to flow cytometry analyses, chromosome counting was considered as a confirmative method for ploidy recognition once again.

### Acknowledgment

The authors are grateful to Prof. Dr. Metin Tuna for his help with the flow cytometry analysis and Tekirdağ Namık Kemal University, Agriculture Faculty, Department of Agricultural Biotechnology for providing laboratory infrastructure. We would like to express our gratitude to Ankara University Faculty of Agriculture-Research Station for Viticulture in Kalecik for providing the experimental grapevine materials.

### References

- Acanda Y; Prado M J; González M V & Rey M (2013). Somatic embryogenesis from stamen filaments in grapevine (*Vitis vinifera* L. cv. Mencía): Changes in ploidy level and nuclear DNA content. *In Vitro Cell. Dev. Biol. Plan*, 49: 276-284.
- Acanda Y; Martínez Ó; González M V; Prado M J & Rey M (2015). Highly efficient *in vitro* tetraploid plant production via colchicine treatment using embryogenic suspension cultures in grapevine (*Vitis vinifera* cv. Mencía). *Plant Cell Tissue and Organ Culture (PCTOC)* 123(3): 547-555.
- Aihong M; Parga F; Jiarshu S & Shaohua L (2005). Study on the induction of tetraploid grapes. *Scientia Agricultura Sinica* 38(8): 1645-1651.
- Allum J F; Bringloe D H & Roberts A V (2007). Chromosome doubling in a *Rosa rugosa* thunb. Hybrid by exposure of *in vitro* nodes to oryzalin: The

effects of node length, Oryzalin concentration and exposure time. *Plant Cell Rep* 26:1977-1984

Aradhya M K; Dangl G S; Prins B H; Boursiquot J M; Walker M A; Meredith C P & Simon C J (2003). Genetic structure and differentiation in cultivated grape, *Vitis vinifera* L. *Genetics Research* 81(3): 179-192.

Blasco M; Badenes M L & Naval M M (2015). Colchicine-induced polyploidy in loquat (*Eriobotrya japonica* (Thunb.) Lindl.). *Plant Cell Tiss Org.* 120(2): 453-461.

Chang Y Y; Ji X; Zhu J L & Hao Y (2014). Polyploidy induction of mutation by using colchicine on tube seedlings of Victoria grape. Xth Intl. Conf. On Grapevine Breeding and Genetics, 1-5 August, Proceedings, 265-270, United States of America.

Chen J; Tang X; Ma X; Zhao Q & Dong Z (2014). Generation of a new polyploid grape cultivar by using hybrid seeds induced with colchicine. *Acta Horticulturae* 1046:251-258.

Cruzan M; Streisfeld M & Schwoch J (2020). Fitness Effects of Somatic Mutations Accumulating during Vegetative Growth. *BioRxiv*, doi: 10.1101/392175.

Ekbiç H B & Tangolar S (2016). Possibilities to generate polyploidy using different colchicine doses in Trakya İlkeren and Flame Seedless grape cultivars *Academic Journal of Agriculture* 5(2): 69-76.

Escandón A S; Alderete L M & Hagiwara J C (2007). *In vitro* polyploidization of *Mecardonia tenella*, a native plant from South America. *Scientia Horticulturae* 115(1):56-61.

Fong S W (2008). *In vitro* induction of polyploidy in *Nepenthes gracilis*. Master's Degree, University of Malaya Kuala Lumpur, Faculty of Science, 95, Kuala Lumpur.

Glowacka K; Jezowski S & Kaczmarek Z (2010). Impact of colchicine application during callus induction and shoot regeneration on micropropagation and polyploidisation rates in two *Miscanthus* species. *In Vitro Cell. Dev. Biol. Plant* 46:161-171.

Guo Y; Zhao Y; Li K; Liu Z; Lin H; Guo X & Li C (2011). *In vitro* embryo rescue culture of F1 progenies from crosses between tetraploid grape and *Vitis amurensis* Rupr. *African Journal of Agricultural Research* 6(21): 4906-4909.

Kuliyev V M (2020). The Study of Polyploid Mutant Forms of Grapes. *Cytology & Histology International Journal* 4(1):1-6.

Keskin N & Kunter B (2009). The Effects of Callus Age, UV Irradiation and Incubation Time on trans-Resveratrol Production in Grapevine Callus Culture. *Journal of Agricultural Sciences* 15:(1): 9-13.

- Keskin N & Kunter B (2010). Asmada (*Vitis vinifera* L.) *in vitro* I. Tip Kallus Eldesi Üzerine Çeşit, Besin Ortamı ve Eksplant Tipinin Etkisi. Yüzüncü Yıl Üniversitesi Tarım Bilimleri Dergisi 20 (2):100-106.
- Kunter B & Karataş Değirmenci D (2011). Mutations in Grapevines and Mutant *Vitis Vinifera* L. Varieties. Yuzuncu Yıl University Journal of Agricultural Sciences 21(2):146-151.
- Leal F; Loureiro J; Rodriguez E; Pais M S; Santos C & Pinto-Carnide O. (2006). Nuclear DNA content of *Vitis vinifera* cultivars and ploidy level analyses of somatic embryo-derived plants obtained from anther culture. Plant Cell Rep. 25: 978-985.
- Manzoor A; Ahmad T; Bashir M A; Hafiz I A & Silvestri C (2019). Studies on colchicine induced chromosome doubling for enhancement of quality traits in ornamental plants. Plants 8(7): 194.
- Martinelli L & Gribaudo I (2009). Strategies for effective somatic embryogenesis in grapevine: an appraisal. In: Angelakis- Roubelakis KA (ed) Grapevine Molecular Physiology & Biotechnology. Springer, Dordercht, 461-493.
- Mitani N; Ban Y; Sato A & Kono A (2014). Tetraploid table grape breeding in Japan. Xth Intl. Conf. on Grapevine Breeding and Genetics. Proceedings, 225-230.
- Murashige T & Skoog F (1962). A revised medium for the rapid growth and bioassay with tobacco tissue culture. Physiol. Plant. 15: 473-479.
- Nadler J D; Pooler M; Olsen R T & Coleman G D (2012). *In vitro* induction of polyploidy in *Cercis glabra* Pamp. Scientia Horticulturae 148: 126-130.
- Notsuka K; Tsuru T & Shiraishi M (2000). Induced polyploid grapes via '*in vitro*' chromosome doubling. J. Japan. Soc. Hort. Sci. 69(5): 543-551.
- Petersen K K; Hagberg P & Kristiansen K (2003). Colchicine and oryzalin mediated chromosome doubling in different genotypes of *Miscanthus Sinensis*. Plant Cell Tissue Organ Cult. 73:137-146.
- Prado M J; Rodriguez E; Rey L; Gonzalez M V; Santoz C & Rey M (2010). Detection of somaclonal variants in somatic embryogenesis regenerated plants of *Vitis vinifera* by flow cytometry and microsatellite markers. Plant Cell Tiss Organ Cult. 103: 49-59.
- Rego M; Reigo E; Bruckner C; Finger F & Otoni W (2011). *In vitro* induction of autotetraploids from diploid Yellow Passion fruit mediated by colchicine and oryzalin. Plant Cell Tiss Organ Cult. 107: 451-459.
- Sinski I; Bosco D B; Pierozzi N I; Maia J G D; Ritschel P S & Quecini V (2014). Improving *in vitro* induction of autopolyploidy in grapevine seedless cultivars. Euphytica 196: 299-311.

- Tuna G S; Keleş H; Göçmen D; Güleriyüz V; Nizam İ; Cabi E & Tuna M (2016). Characterisation of genetic resources of perennial forage grasses by using flow cytometry. *Journal of Central Research Institute for Field Crops* 25 (Special Issue-2): 7-12.
- Xie X; Agüero C B; Wang Y & Walker M A (2015). *In vitro* induction of tetraploids in *Vitis* × *Muscadinia* hybrids. *Plant Cell, Tissue and Organ Culture (PCTOC)* 122(3): 675-683.
- Xu X; Lu J & Bradley F (2014). Applications of polyploids in Muscadine grape (*Vitis Rotundifolia* michx.) breeding. Xth Intl. Conf. on Grapevine Breeding and Genetics. Proceedings 411-417.
- Vezzulli S; Leonardelli L; Malossini U; Stefanini M; Velasco R & Moser C (2012). Pinot blanc and Pinot gris arose as independent somatic mutations of Pinot noir. *Journal of Experimental Botany* 63(18): 6359-6369.
- Yun H K; Park K S; Roh J H, Kwack Y B; Jeong J; Kim S H; Jang H I & Shin Y U (2008). Table grape 'Suok'. *Hort. Sci.* 43: 2224-2225.
- Zeng S H; Chen C W; Hong L; Liu J H & Deng X X (2006). *In vitro* induction, regeneration and analysis of autotetraploids derived from protoplasts and callus treated with colchicine in Citrus. *Plant Cell, Tissue and Organ Culture* 87(1): 85-93.
- Zhang Z; Dai H; Xiao M & Liu X (2008). *In vitro* induction of tetraploids in *Phlox subulata* L. *Euphytica* 159(1-2): 59-65.

# CHAPTER 7

## A REVIEW ON PRODUCTION OF SECONDARY METABOLITES IN GRAPEVINE BY CALLUS CULTURE

Nurhan KESKİN

(Assoc. Prof. Dr.), Van Yüzüncü Yıl University,  
Faculty of Agriculture, Department of Horticulture,

Van, Türkiye, e-mail: keskin@yyu.edu.tr

 0000-0003-2332-1459

### 1. Introduction

Plant chemicals are divided into primary and secondary metabolites. Phosphates, sugars, proteins, amides, amino acids, nucleotides, nucleic acids, organic acids and chlorophylls formed the indispensable primary metabolites of the plants for physiological development. For protection of themselves, adaptation to ecological conditions and continue their generations of plants, low-molecular substances are synthesized biosynthetically from primary metabolites and these are called secondary metabolites (Oskay & Oskay 2009). Secondary metabolites are not directly related to the developmental activities of the plant such as growth, photosynthesis, and product transformation. These compounds are synthesized in specific ways by specific biosynthetic enzymes in tissues, organs and growth parts of the plant. They are stored in plant organs in high concentrations (1-3 % by dry weight). It is important to interdisciplinary study field about positive effect of secondary metabolites which act like phytochemicals and phytoalexin on human health. In addition, the studies about the mechanism of phytoalexin production in plants and increasing production by different metabolic pathways have been continued. For human life, it is disadvantage to synthesis naturally less amount of secondary metabolites in plants. Today, secondary metabolites which have economic value can be produced by using plant tissue culture techniques and the production levels of targeted secondary metabolites can be increased by using various biotic or abiotic

elicitors. Grapevine (*Vitis vinifera* L.), which is take part in many areas such as nutrition, pharmacy and cosmetics, is very rich for secondary metabolites. In this study, secondary metabolite production by callus culture in grapevine was evaluated in the light of the literature.

## 2. Grapevine Secondary Metabolites

### 2.1. Phenolic compounds

Phenolic compounds are known to have supportive effects on nutrition and health, and these are the most important components of quality with determining color, taste and aroma of grapes (Kunter *et al.* 2013). Although phenolic compounds containing at least one aromatic ring and at least one hydroxyl group attached to this ring can be classified in different ways, they are generally divided into two groups as flavonoids and non-flavonoids. It contains flavonoids, tannins (flavan-3-ols), flavonols and anthocyanins. Non-flavonoids are composed of phenolic acids and stilbenes (López-Vélez *et al.* 2003).

#### 2.1.1. Flavonoids

As quantity, the majority is flavonoids in grapes. The structure of flavonoids consist of A and B aromatic rings as well as a hydroxyl ring bonded with three carbons and often called C ring. With depending on the differences of the C ring, these compounds are named as flavonols (kaemferol, myricetin, and quercetin), flavones (apigenin and luteolin), flavan-3-ols (catechin, epicatechin, epigallocatechin, and epicatechin gallate), flavanones (naringenin), anthocyanidins and isoflavonoids (genisteine, daidzein, dihydro daidzein, and equol) (Gökçen *et al.* 2017).

It can be stated that flavonols, tannins and anthocyanidins are the most important ones in grapes.

*Tannins (flavan-3-ols)*: Tannins are complex structures consisting of esters of sugars and phenolic compounds found in the stem, berry skin and seeds of grapes (Harbetson *et al.* 2002).

Tannins which is interim product in flavonoid biosynthesis are colorless compounds and are also called “flavan-3-ols” to determine the location of the hydroxy group on the C ring. Tannins are chemically divided into two groups as hydrolyzable tannins and condensed tannins (Haslam, 1998). (+)-catechin, (-)-epicatechin, (+)-gallocatechin, (-)-epigallocatechin and (-)-epigallocatechin 3-gallate are the most existing condensed tannin structures in berries.

**Flavonols:** The flavonols found in grapes are quercetin, kaemferol, myricetin and isoramnetin. They exist glycosides form with mostly combining to sugars.

**Anthocyanins:** Anthocyanins are the most comprehensive subgroup of phenolic substances. They are found in the skin of grapes and are defined as natural colorants that give grapes their distinctive red, blue and purple hues (Ho *et al.* 2001). As maturity progresses, anthocyanidins which are free aglycone form anthocyanins combining with sugars. Anthocyanidins found in grapes are malvidin (purple), cyanidin (red), peonidin (light red), petunidin (blue-purple), and delphinidin (dark blue). As the number of hydroxyl groups (-OH) in the anthocyanin molecule increases, their color changes to blue, and as the number of methoxyl group (-OCH<sub>3</sub>) increases, they turn red (Mullins *et al.* 1992).

### 2.1.2. Non-flavonoids

**Phenolic acids:** Phenolic acids found excessive amount in grapes. These are generally benzoic acid derivatives with seven carbon atoms (C<sub>6</sub>-C<sub>1</sub>) and cinnamic acid derivatives with nine carbon atoms (C<sub>6</sub>-C<sub>3</sub>).

Natural phenolic acids are found in either free or conjugated form. They usually are in the form of esters or amides. Hydroxycinnamic acid derivatives are a group of phenolic compounds found in large amounts in must and white wines. Caffeic, coumaric and ferulic acids are the most common hydroxycinnamic acid derivatives in grapes and wines. Laristrin and syringin derivatives have also been determined in black grape varieties (Mattivi *et al.* 2006).

**Stilbenes:** Stilbenes are phenolic compounds synthesized under stress conditions. Two aromatic rings linked by methylene bridge form their basic molecular structure (Soleas *et al.* 1997).

The presence of stilbenes in grapes was determined firstly by Langcake & Pryce (1976) in some grapevine genotypes. Although the stilbene compound synthesized in high amounts in grapes is *trans*-resveratrol (*t*-RSV=3,4',5-trihydroxy-stilbene), other stilbene compounds, many of which are in the dimer, trimer or tetramer structure of resveratrol, have also been determined. The most important of these compounds are *trans*- and *cis*-piceid (resveratrol glycoside),  $\epsilon$ -viniferin (*trans*-resveratrol dimer), piceatannol (*trans*-3,3',4,5'-tetrahydroxy-stilbene), pterostilbene (*trans*-3,5-dimethoxy-4'-tetrahydroxy-stilbene), and pallidol (*trans*-resveratrol dimer) molecules (Bavaresco *et al.* 2002; Keskin & Kunter 2017).



## 2.2. Major Aroma Compounds

### 2.2.1. Terpenes

Terpenes play roles as antioxidants, phytohormones, protein modification reagents, repellents of herbivores and attractants of predators, and parasitoids of herbivores (Pichersky & Raguso 2018). The grape terpenoids of major aromatic importance in grapes can be divided into monoterpenes ( $C_{10}$ ) and sesquiterpenes ( $C_{15}$ ) according to their chemical structure. Moreover, carotenoids ( $C_{40}$ ) can be included in this list as aroma precursors (Rienth *et al.* 2021).

There are approximately 50 terpene compounds identified in grapes and wines (Black *et al.* 2015; Ilc *et al.* 2016). Terpene compounds contribute to the formation of many different aromas such as honey and wax, oily notes, lemon and citrus, as well as characteristic floral scents such as intense rose, chamomile and lavender (Canturk & Kunter 2019).

### 2.2.2. Norisoprenoids

$C_{13}$  norisoprenoids are aroma compounds released as a result of the breakdown of carotenoids which are the 40-carbon ( $C_{40}$ -tetraterpenes) group of terpenes by chemical reactions. During the processes such as ripening, maceration, fermentation and aging, carotenoids are reduced to  $C_9$ ,  $C_{10}$ ,  $C_{11}$  and  $C_{13}$  compounds which are more soluble in the must, more volatile and give a more intense odor by exposing to oxidation with polyphenoloxidase and lipoxygenase enzymes in grapes. Among these compounds derived from carotenoids,  $C_{13}$  norisoprenoids gained importance with their contribution to the distinctive character of grapes and some wines (Darriet *et al.* 2002, Moreno & Peinado 2012). In grapevine, carotenoids are cleaved via carotenoid cleavage dioxygenases (CDD) to form norisoprenoids with  $C_{13}$  carbons ( $C_{13}$  norisoprenoids) such as  $\beta$ -ionone,  $\beta$ -damascenone, vitispirane, actinidol, 4-(2,3,6-trimethylphenyl) buta-1,3-diene (TPB), 1,1,6-trimethyl-1,2-dihydronaphthalene (TDN), and 2,2,6-trimethylcyclohexanone (TCH) (Rienth *et al.*, 2021).

### 2.2.3. Fatty Acid Derivates

Aromas in this group consist of saturated and unsaturated  $C_6$  alcohols and aldehydes which are formed as a result of the decomposition of linoleic and linolenic acids in grapes by lipoxygenase activity. In general,  $C_6$  compounds produce a vegetal (green, herbal) aroma and are often found in undetectable amounts in wines. Until now, hexanal, (E)-2-hexenal, (Z)-3-hexenal, hexanol-1, (E)-2-hexen-1-ol and (Z)-3-hexen-1-ol compounds have been detected.

### 2.2.4. Methoxypyrazines

In general, methoxypyrazines are nitrogenous heterocyclic compounds. These are found in free form in grapes and have no precursor compounds. Three methoxypyrazine groups have been identified in grapes (Figure 3): 2-methoxy-3-isobutylprazine (IBMP), 2-methoxy-3-isopropylprazine (IPMP), and 2-methoxy-3-s-butylprazine (s-BMP). In grapes, isobutyl methoxypyrazine is the most one of these.

Methoxypyrazines are compounds that give vegetative (herbal, herbaceous), green, green pepper, asparagus and sometimes earthy aromas to wines (Conde *et al.* 2007). They are found considerable amounts in Cabernet Sauvignon, Sauvignon Blanc, Cabernet Franc and Merlot grapes and wines of these.

### 2.2.5. Thiols

Thiols are volatile sulfur compounds and crucial components of the ‘varietal character’ of several cultivars. 4-methyl-4- sulfanylylpentan-2-one (4MSP), 4-merthyl-4-sulfanylpentan-2-ol (4MSPOH) and the 3- sulfanylhexan-1-ol (3SH) are the most important thiols present as precursors in the berry of white wine cultivars (Rienth *et al.* 2021).

## 3. Advantages of Secondary Metabolite Production via Plant Tissue Culture

Various difficulties are encountered during the extraction of secondary metabolites which have a wide range of uses from plants under natural conditions. These are summarized as follows (Tanur-Erkoyuncu & Yorgancilar 2016)

- *It is difficult and expensive to collect these plants which usually grow in natural flora,*
- *As a result of the continuous collection of plants from nature, their generation disappears over time,*
- *The amount and quality of secondary metabolites are affected by climatic conditions,*
- *Active substances are synthesized in these plants at certain stages of development and in very small amounts,*
- *Low success rate in the cultivation of plants,*
- *To need large agricultural areas for the production of effective substances in economic quantities.*

Limited production for these and similar reasons cannot supply adequately the increase in demand in the use of natural substances with the change in consumer demands. In order to avoid all these problems, plant tissue cultures are seen to be an alternative method for the production of secondary metabolites.

Plant tissue and cell culture is the generation of products new tissue, plant or plant products (such as metabolites) from a whole plant, cell (meristematic, suspension or callus cells), tissue (various plant parts = explant) or organ (root, apical meristem etc.) in aseptic conditions and an artificial nutrient medium (Babaoğlu *et al.* 2001).

It is known that many environmental and nutritional factors are effective in the biosynthesis pathway of secondary metabolites. Plant tissue cultures and nutritional factors in the culture medium; that is carbon, phosphorus, nitrogen sources and other macro elements and plant growth regulators namely auxin and cytokinins affect both metabolite formation and growth. In addition to chemical factors, physical factors such as temperature and light in the environment can also have a direct or indirect effect on *in vitro* secondary metabolite production. Each of these factors has an effect according to the cultivated plant, culture type and even the age of the culture (Gundlach *et al.* 1992; Sökmen & Gürel. 2001; Bhagyalakshmi *et al.* 2004; Matkowski. 2008).

One of the most important roles of secondary metabolites is that they are developed in response to stress factors (Grassman *et al.* 2002). Biotic and abiotic elicitors (stimulants) that cause stress are applied to obtain secondary metabolites in high amounts (Barz *et al.* 1988; Verporte *et al.* 2002; Vanisree & Tsay 2004).

By optimizing culture conditions, there are a number of advantages to producing secondary metabolites via plant cell and tissue cultures. These advantages are as follows (Tanur-Erkoyuncu & Yorgancılar 2016);

- *Environmental factors (climate, geographical difficulties and seasonal restrictions) encountered during the culture of the plant are eliminated,*
- *Less area use is provided,*
- *The extinction of the plant is prevented by collecting it from nature,*
- *It is ensured that economically valuable metabolites which are found in low amounts in plants can be produced in sufficient quantities,*
- *Homogeneity, standard quality and efficiency are ensured in production,*
- *It helps to understand the biosynthesis mechanisms of metabolites.*

With all these advantages, the production of secondary metabolites can be performed faster, simpler, more reliable and more predictable than conventional methods.

#### 4. Callus Culture

By plant tissue and cell culture, there are basically three different systems in production of secondary metabolites. These are root cultures, shoot cultures and callus cultures.

Callus can be defined as masses with morphological irregularities formed as a result of culturing organs or tissue parts which cut out from the mother plant and have not lost their ability to divide under *in vitro* conditions.

Callus culture is the culture of differentiated plant cells that is usually induced *in vitro* conditions containing high auxin concentrations or an auxin/cytokinin combination.

Callus formation from an explant constitute three stages:

- (a) *Induction phase*: Metabolism is stimulated and cells are prepared to divide. The cell size remains unchanged.
- (b) *Cell division phase*: Cells divide actively and the cell size becomes smaller. Cell division is mainly periclinal and wound occurs towards to periphery leading cambial cells.
- (c) *Differentiation*: Differentiation of cells results in root or shoot formation. As a result of this differentiation, there is an increase in the accumulation of secondary metabolites in some cells.

#### 5. Studies on Secondary Metabolite Production by Callus Culture in Grapevine

Table 1 summarizes the studies about secondary metabolite production by callus culture in grapevine.

As illustrated in Table 1, the secondary compounds produced by callus culture in grapevines concentrate on phenolic compounds, especially anthocyanin and stilbenes. Keller *et al.* (2000), stated that tissue cultures can be used as a model system to explain the response mechanisms of plants to environmental conditions. Keller *et al.* (2000) are also the first researchers group to demonstrate that stilbene compounds can be produced via callus cultures in grapevines. Although previous studies reported that stilbene production is related to *Botrytis cinerea* contamination in Cabernet Sauvignon calluses, these researchers

indicated that stilbene compounds, mainly resveratrol and  $\epsilon$ -viniferin, can be synthesized with only application of UV light without a biotic elicitor.

By the callus culture in grapes, the factors affecting the secondary metabolite production are presented as follows:

### 5.1. Genotype

Success in plant tissue and cell culture largely depends on the genotype of the donor plants. Torregrossa *et al.* (1995) and Nakano *et al.* (1997) stated that the success of callus formation in the *in vitro* conditions varies to grape varieties. As shown in Table 1, significant differences observed between species in the studies on secondary metabolite production by callus culture in grapevine. Furthermore it can be stated that the capabilities of different genotypes and cultivars within the same species are different.

### 5.2. Explant Source

Basically a callus culture starts with setting a piece of plant tissue (leaf, root stem, etc.) (explant) in a previously sterilized container (petri, flask, etc.) containing nutrients. The origin of the tissue piece is important for production of secondary metabolites in callus culture. Leaf blades (Nakano *et al.* 1997; Jayasankar *et al.* 1999) and internodes (Thomas 2001) are explants with high callus formation potential and these are used extensively in tissue culture studies. It is considered that leaf blade, petiole and node are used in the studies on secondary metabolite production by callus culture in grapevine (Figure 1, Table 1).

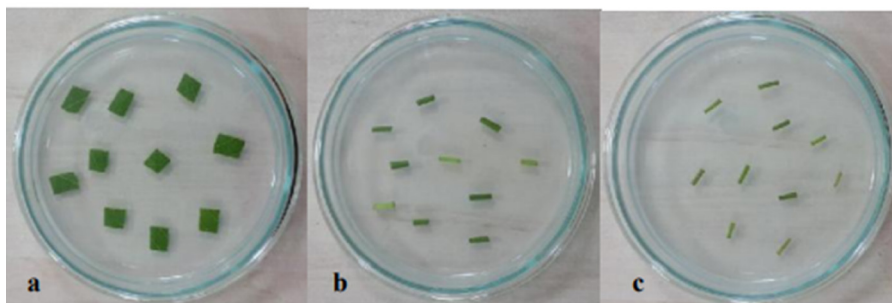


Figure 1. Explant sources a: leaf blade, b: internode, c: petiole (Photo: N. Keskin).

Explants can be taken from the shoots of grapevines grown in vineyard conditions, or cuttings of one-year-old canes were forced to give shoots under *in vivo* controlled conditions (Figure 2) in order to reduce the risk of infection or ideally from *in vitro* plantlets (Figure 3).



Figure 2. Cuttings of one-year-old canes were forced to give shoots under *in vivo* controlled conditions (Photo: N. Keskin).



Figure 3. *In vitro* plantlets (Photo: N. Keskin).

### **5.3. Cultural Environment Components and Culture Conditions**

For plant tissue and cell cultures, each chemical in the nutrient medium is actually like to an inciting or limiting factor for both growth and secondary metabolite production. For example, any substance in the nutrient medium can reduce metabolite accumulation while promoting growth. Therefore, when secondary metabolite is produced, the chemical components of the nutrient medium should be in such a way as to provide the optimum in both growth and metabolite production (Sökmen & Gürel 2001).

The main components of the culture medium are calcium, magnesium nitrogen, phosphorus, potassium, and sulfür which are known as macro elements;

boron, copper, iron, manganese, molybdenum, and zinc which are known as microelements; carbon source (glucose, maltose, starch sucrose), vitamins, myo-inositol and plant lactose, growth regulators. Nowadays, various culture media have been developed that form the basis for media. Each plant species, and even each metabolite requires its own specific environment (Alvarez 2014). Media components affect both primary and secondary metabolism. As indicated in Table 1, B5 (Gamborg *et al.* 1968) and MS (Murashige & Skoog 1962) basic media are used for secondary metabolite production in grapevine callus cultures. B5 medium is a high nitrate nitrogen medium developed for soybean callus cultures, while MS medium is a high salt medium developed for tobacco.

Sucrose is used as a carbon source in most plant tissue cultures. Sucrose concentration in the medium was 3% (w/v) in the studies on secondary metabolite production by callus culture in grapevine.

Plant Growth Regulators (PGRs) added to the culture medium have a significant effect on cell growth and secondary metabolite production. PGRs are plant-organic molecules that affect physiological processes such as growth, differentiation and development at low concentrations (Topçu & Çölgeçen 2015). PGRs are commonly classified as auxins, cytokinins, gibberellins, ethylene, abscisic acid and jasmonic acid. PGRs used for secondary metabolite production in grapevine callus cultures are Indole-3-acetic acid (IAA), naphthalene acetic acid (NAA) and 2,4-Dichlorophenoxyacetic acid (2,4-D) from auxins while 6-benzylaminopurine (BAP), N6-Benzyladenine (BA), and Kinetin (Kin) from cytokinins (Table 1).

In callus cultures, temperature is effective on biomass increase and secondary metabolite production. It is noteworthy that the ideal temperature is 22-26 °C for secondary metabolite production in grapevine callus cultures (Table 1).

Light affects metabolite accumulation in tissues and cells, in addition, photoperiod as well as light quality and intensity are important parameters for production of secondary metabolites and especially phenolic compounds. The important effect of light on the regulation of enzymes functioning in the phenyl propanoid metabolic pathway can be shown as causing the production of phenolic compounds in cell cultures to be affected by both light quality and light intensity (Hahlbrock 1977). It can be stated that the light used for secondary metabolite production in grapevine callus cultures is photoperiodic lighting (16 hours of light:8 hours of dark) or darkness (Table 1).



#### 5.4. *Callus Quality and Age*

It is desirable that the callus tissue to be used in the production of secondary metabolites should be white, easily dispersed, crispy and full (Figure 6) (Keskin & Kunter 2010a).

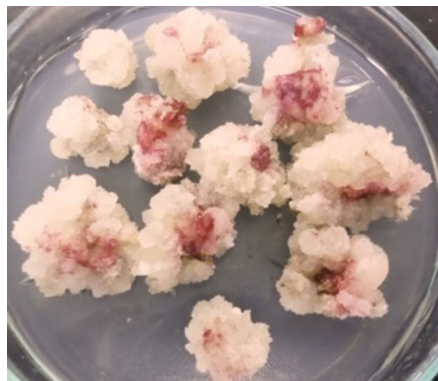


Figure 4. Callus suitable for secondary metabolite production (Photo: N. Keskin).

The quality and age of the calli to be applied elicitor affect the success in the production of secondary metabolites with callus cultures. After subcultured of calli, cell proliferation begins, peaks rapidly, and passes into the ‘stationary cell growth phase’, which is the most favorable period for secondary product production. It has been suggested that this period corresponds to the 12<sup>th</sup> day after the second subculture in grapevines (Keskin & Kunter 2008).

#### 5.5. *Elicitor Application*

Elicitors are compounds that activate the synthesis of another compound when they encounter a living organism. Secondary metabolite production increase when callus cultures are subjected to various biotic (enzymes, cell wall parts of microorganisms, microorganism polysaccharides such as glycoproteins, chitin, glucan, phytochemicals produced by the plant against physical damage, fungal or bacterial attacks, plant cell wall polysaccharides such as chitosan, cellulose, pectin, glucans, salicylic acid) or abiotic (heavy metals, inorganic salts, Ultra violet (UV) light, extreme salinity, extreme temperature and high pressure, high or low osmolarity) factors. As demonstrated in Table 1, UV light is the leading elicitor used for secondary metabolite production in grapevine callus cultures (Figure 5).

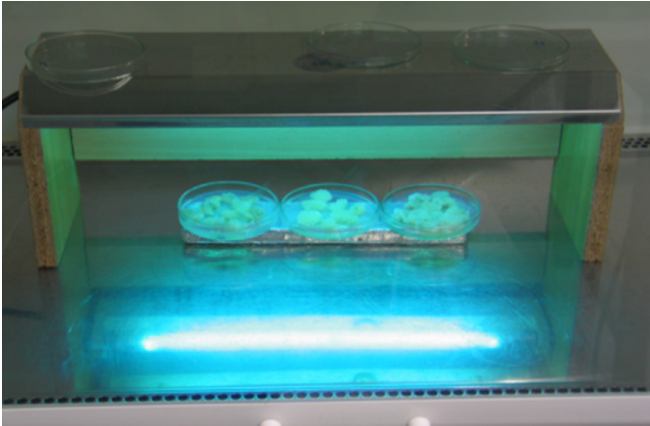


Figure 5. UV irradiation on callus cultures (Photo: N. Keskin)

## Conclusion

Considering the importance of secondary metabolites, especially in health, biotechnological developments targeting large-scale production are promising. The current review deciphers secondary metabolite production of from grapevine by callus cultures. However, it is necessary to use elicitors to induce and maintain high levels of secondary metabolites production in callus cultures. It can be stated that there have been few studies about the mechanisms of elicitation promoting regarding with secondary metabolites production. Among various abiotic elicitors, UV has been still popular for boosting secondary metabolite production in grapevine. Further investigation is required before we can rightly identify the best method of secondary metabolites production in grapevine by callus culture.

**Table 1.** Studies on secondary metabolite production by callus culture in grapevine

Species/Cultivar	Eksplant	Medium Content	Incubation Condition	Elicitor	Compounds	References
<i>V. vinifera</i> L. cv. 'Muscat Bailey A'	The stems near the bunch	B5 + 5 mg/L NAA + 1 mg/L Kin	25°C, 2000 lux	-	Anthocyanin	Tamura <i>et al.</i> (1989)
<i>V. vinifera</i> L. cv. 'Cabernet Sauvignon'	Leaf blade	B5 + 1.0 µM BAP + 0.1 µM 2,4-D + 3% sucrose + 0.8% agar	Dark conditions at 25°C	UV-C	<i>t</i> -piceid, <i>t</i> -RSV, <i>ε</i> -viniferin, unknown <i>t</i> -stilbene	Keller <i>et al.</i> (2000)
<i>V. vinifera</i> L. cvs. 'Regent', 'Nero'	Unspecified	MS + 10 mg/L IAA + 0.2 mg/L BAP + 40g/L sucrose on a filter bridge system	22°C, 16 h 60 µEm <sup>-2</sup> s <sup>-1</sup>	Epiphytic yeast <i>Aureobasidium pullulans</i>	catechin, epicatechin, epicatechin-gallat, <i>p</i> -coumaric acid, <i>cis</i> - and <i>t</i> -piceid anthocyanins, <i>t</i> -RSV	Rühmann, (2005)
<i>V. vinifera</i> L. cvs. 'Erciş', 'Cabernet Sauvignon', 'Kalecik Karası', 'Öküzgözü'	Leaf blade	B5 + 1.0 µM BAP + 0.1 µM 2,4-D + 3% sucrose + 0.8% agar	Dark conditions at 25°C	UV-C	<i>t</i> -RSV	Keskin & Kunter (2007); (2008); (2009); (2010b)
'Zhi 168' ( <i>Vitis monticola</i> x <i>Vitis riparia</i> ), 'Beta' ( <i>Vitis labrusca</i> x <i>V. riparia</i> ), <i>V. vinifera</i> L. cvs. 'Merlot', 'Jingxu'	Leaf blade and from 'Beta' leaf, grape exocarp and seed	B5 + 0.1 mg/L BA + 0.1, 0.5 1.0 mg/L 2,4-D + 2.0, 3.0 4.0 mg/L NAA	Dark conditions at 25 ± 2°C	UV-C	<i>t</i> -piceid, <i>c</i> -piceid, <i>t</i> -RSV, <i>c</i> -RSV,	Liu <i>et al.</i> (2010)
<i>V. vinifera</i> L. cv. 'Isabelle'	Immature pericarp of grape berries	B5 + 0.1 mg/L NAA + 0.2 mg/L Kin + 2 mg/L casein hydrolysisate + 3% sucrose + 8 g/L agar	24-26°C, 1500 lux cold fluorescent light 16/8 h photoperiod	Manitol, abscisic acid, salicylic acid, jasmonic acid	Anthocyanin	Mihai <i>et al.</i> (2009) (2010)
<i>V. vinifera</i> L. cv. 'Gamay'	Petiole	B5 + 0.5 mg/L BAP + 0.5 mg/L IAA + 3% sucrose + 0.8% agar	Dark conditions at 25°C	UV-C	Total phenolics, total flavanols, total flavonols, anthocyanin, catechin, <i>t</i> -RSV, ferulic acid	Çetin <i>et al.</i> ; 2011; Çetin, 2012

Table 1. (Continued)

Species/Cultivar	Eksplant	Medium Content	Incubation Condition	Elicitor	Compounds	References
<i>V. vinifera</i> L. cv. 'Bogazkere'	Leaf discs	B5 + 0.2 mg/L BA + 0.02 mg/L 2, 4-D and then subcultured MS + 1 mg/L NAA + 0.1 mg/L BA	16/8 h photoperiod at 24 ± 1°C	Percent depletion of $KH_2PO_4$ or $NH_4NO_3$ and light intensity	Total phenolics, anthocyanin,	Karaaslan <i>et al.</i> (2013)
<i>V. vinifera</i> L. cvs. 'Burgund Mare', 'Cabernet Sauvignon', 'Oporto', 'Merlot', 'Negru Timctorial', 'Pinot Noir'	Internode tissue, petiole, foliar tissue and tendrils	MS + 2 mg/L NAA + 0.5 mg/L Kin + 3% sucrose	16/8 h photoperiod at 24-25°C, relative humidity of 0-60%.	-	Anthocyanin	Lazár <i>et al.</i> 2013
<i>V. vinifera</i> L. cv. 'Öktüzgözü'	Petiole	B5 + 0.5 mg/L BAP + 0.5 mg/L IAA + 3% sucrose + 0.8% agar	25 ± 1°C.	UV-C	Total phenolic, total flavanols, catechin, carotenoid, ferulic acid, <i>t</i> -resveratrol	Çetin, 2014
<i>V. vinifera</i> L. cv. 'Gellewza'	Internode	MS + PGRs	16/8 h photoperiod at 24°C	PGRs	Polyphenolics, phenolic acids, coumarins, stilbenes, flavonoids	Bonello <i>et al.</i> (2019)
Unspecified	Leaf blade, petiole	Initial culture MS + 1 mg/L BAP + 0.5 mg/L NAA + 3% sucrose + 0.75% agar and then callus culture MS + 1, 1.5 and 2 mg/L BAP + 3% sucrose + 0.75% agar B5 + 3 different combination (2 mg/L NAA; 0.5 mg/L Kin + 5 mg/L NAA + 1 mg/L Kin; 0.1 mg/L NAA; 0.2 mg/L Kin) + 3% sucrose + 0.8% agar	14 h light at 26°C	-	<i>t</i> -resveratrol	Kaewpiboon & Boonnak, 2019
<i>V. vinifera</i> L. cv. 'Karaerik'	Leaf blade	B5 + 0.1 mg/L NAA + 0.2 mg/L Kin) + 3% sucrose + 0.6% agar	16/8 h photoperiod at 25°C	UV-C	Anthocyanin	Oğuz <i>et al.</i> (2020)
<i>V. vinifera</i> L. cv. 'Karaerik'	Leaf blade	B5 + 0.1 mg/L NAA + 0.2 mg/L Kin) + 3% sucrose + 0.6% agar	16/8 h photoperiod at 25°C	UV-C	Total and individual phenolics	Çelik <i>et al.</i> (2020)

## References

- Alvarez MA (2014) Plant Biotechnology for Health: From Secondary Metabolites to Molecular Farming, Springer International Publishing.
- Babaoğlu M; Yorgancılar M & Akbudak M A 2001. Doku Kültürü: Temel Laboratuar Teknikleri. Bitki Biyoteknolojisi I- Doku Kültürü ve Uygulamaları (Ed. Babaoğlu M; Gürel E & Özcan S), Selçuk Üniversitesi Yayınları, Cilt I, 1-35.
- Barz W; Daniel S; Hindeer W; Jaques U; Kessman H; Koster J; Otto C & Tiemann K (1988). Elicitation and metabolism of phytoalexins in plant cell cultures. In: Application of plant cell and tissue culture, CIBA Foundation Symposium 137, Toronto, 178-198.
- Bavaresco L; Fregoni M; Trevisan M; Mattivi F; Vrhovsek U & Falchetti R (2002). The occurrence of the stilbene piceatannol in grapes. *Vitis* 41 (3):133-136.
- Bhagyalakshmi N; Thimmaraju R; Narayan M S (2004). Various hexoses and di-hexoses differently influence growth, morphology and pigment synthesis in transformed root cultures of red beet (*Beta vulgaris*). *Plant Cell, Tissue and Organ Culture*, 78: 183-195.
- Black C A; Parker M; Siebert; T E; Capone D L & Francis I L (2015). Terpenoids and their role in wine flavour: recent advances. *Aust. J. GrapeWine Res.* 21:582-600.
- Bonello M; Gašić U; Tešić Ž & Attard E (2019). Production of Stilbenes in Callus Cultures of the Maltese Indigenous Grapevine Variety, Gellewza. *Molecules* 24: 2112.
- Canturk S & Kunter B (2019). Üzümlerde Aroma Bileşikleri. *Tarım Bilimlerinde Güncel Araştırma ve Değerlendirmeler*. Eds., Kunter B & Keskin N. Stamparija Ivpe, Cetinje, p.19-28.
- Conde C; Silva P; Fontes N; Dias A C P; Tavares, R M; Sousa M J; Agasse A; Delrot S & Gerós H (2007). Biochemical changes throughout grape berry development and fruit and wine quality. *Food* 1:1-22.
- Çelik M; Keskin N & Özdemir F A (2020). The Effects of UV Irradiation and Incubation Time on *in vitro* Phenolic Compound Production in ‘Karaerik’ Grape Cultivar. *KSU J. Agric Nat* 23 (6): 1428-1434.
- Çetin E S (2014). Induction of secondary metabolite production by UV-C radiation in *Vitis vinifera* L. Öküzgözü callus cultures. *Biological Research*, 47(1): 37-47.

- Çetin E S; Uzunlar F & Baydar N G (2011). UV-C uygulamasının Gamay üzüm çeşidine ait kalluslarda sekonder metabolit üretimi üzerine etkileri. *Gıda* 36(6):319-326.
- Çetin E S; Babalık Z; Baydar N G (2012). Bazı sofralık üzüm çeşitlerinde tanelerdeki toplam karbonhidrat, fenolik madde, antosiyanin,  $\beta$ -karoten ve C vitamini içeriklerinin belirlenmesi. IV. Ulusal Üzümsü Meyveler Sempozyumu, 151-156.
- Darriet P; Thibon C & Dubourdiou D (2012). Aroma and Aroma Precursors in Grape Berry. In: Gerós H; Chaves M & Delrot S (eds). *The Biochemistry of the Grape Berry*; Bentham Science Publishers, The Netherlands, p. 111-136.
- Gamborg O; Miller R & Ojima K (1968). Nutrient requirement suspensions cultures of soybean root cells. *Experimental Cell Research*, 50: 151-158.
- Gökçen İ S; Keskin, N; Kunter, B; Cantürk S & Karadoğan B. 2017. Üzüm fitokimyasalları ve Türkiye’de yetiştirilen üzüm çeşitleri üzerindeki araştırmalar. *Turkish Journal of Forest Science*, 1: 93-111.
- Grassmann J; Hippeli S & Elstner E F (2002). Plant’s de-fence and its benefits for animals and medicine: role of phenolics and terpenoids in avoiding oxygen stress. *Plant Physiology and Biochemistry*, 40: 471-478.
- Gundlach H; Muller J M; Kuthan TM & Zenk M H (1992). Jasmonic acid is a signal transducer in elicitor in-duced plant cell cultures. *Plant Biology* 89: 2389-2393.
- Hahlbrock K (1977) Regulatory aspects of phenylpropanoid biosynthesis in celi cultures. In: Barz W, Reinhard E & Zenk MH (eds), *Plant Tissue Culture and its Bio-technological Application*, pp. 95-111, Springer-Verlag, Berlin, Heidelberg, New York.
- Harbertson J F; Kennedy J A & Adams D O (2002). Tannin in skins and seeds of Cabernet sauvignon, Syrah, and Pinot noir berries during ripening. *American Journal of Enology and Viticulture* 53: 54-59.
- Haslam E (1998). Practical polyphenolics. from structure to molecular recognition and physiological action. Cambridge University Press, p. 422.
- Ho P; Silvia M C & Hogg T A (2001). Changes in colour and phenolic composition during the early stages of maturation of port in wood, stainless steel and glass. *J. Science of Food and Agric*, 81, 1269-1280.
- Ilc T; Werck-Reichhart D & Navrot N (2016). Meta-analysis of the core aroma components of grape and wine aroma. *Front. Plant Sci.* 7:1472.
- Kaewpiboon C & Boonnak N 2019. Effect of Plant Growth Regulators on the Grape Callus Induction and Growth for Secondary Metabolite Production. *Thai Science and Technology Journal*, 27(4): 675-683.

- Karaaslan M; Özden M; Vardin H & Yılmaz F M (2013). Optimisation of phenolic compound biosynthesis in grape (Bogazkere cv.) callus culture. *African Journal of Biotechnology* 12: 3922-3933.
- Keller M; Steel C C & Creasy G L (2000). Stilben accumulation in grapevine tissues: developmental and environmental effects. XXV. International Horticultural Congress, Part 4: Culture Techniques with Special Emphasis on Environmental Implications, *ISHS Acta Horticulturae* 514:275-286.
- Keskin N & Kunter B (2007). Erciş üzüm çeşidinin kallus kültürlerinde UV ışını etkisiyle resveratrol üretiminin uyarılması. *Tarım Bilimleri Dergisi* 13: 379-384.
- Keskin N & Kunter B (2008). Production of transresveratrol in 'Cabernet Sauvignon' (*Vitis vinifera* L.) callus culture in response to ultraviolet-C irradiation. *Vitis* 47(4):193-196.
- Keskin N & Kunter B (2009). The effects of callus age, UV irradiation and incubation time on trans-resveratrol production in grapevine callus culture. *Journal of Agricultural Sciences* 15(1):9-13.
- Keskin N & Kunter B (2010a). Asmada (*Vitis vinifera* L.) *in vitro* I. Tip Kallus Eldesi Üzerine Çeşit, Besin Ortamı ve Eksplant Tipinin Etkisi. *Yüzüncü Yıl Üniversitesi Tarım Bilimleri Dergisi* 20:100-106.
- Keskin N & Kunter B (2010b). Production of trans-resveratrol in callus tissue of Öküzgözü (*Vitis vinifera* L.) in response to ultraviolet-C irradiation. *The J. Anim. Plant. Sci.* 20(3): 197-200.
- Keskin N & Kunter B (2017). Stilbenes Profile in Various Tissues of Grapevine (*Vitis vinifera* L. cv. 'Ercis'). *Journal of Environmental Protection and Ecology* 18:1259-1267.
- Kunter B; Cantürk S & Keskin, N. (2013). Üzüm tanesinin histokimyasal yapısı. *Iğdır Üni. Fen Bilimleri Enst. Der.* 3 (2): 17-24.
- Langcake P & Pryce R J (1976). The production of resveratrol by *Vitis vinifera* and other members of the Vitaceae as a response to infection or injury. *Physiol Plant Pathol.*,9: 77-86.
- Lazăr A; Petolescu C & Peev C (2013). Interrelations between anthocyanins quantity synthesized in callus culture and the period of cultivation at *Vitis vinifera* L. *Romanian Biotechnological Letters* 18: 8467-8474.
- Liu W; Liu C; Yang C; Wang L & Li S. (2010) Effect of grape genotype and tissue type on callus growth and production of resveratrols and their piceids after UV-C irradiation. *Food Chem.* 122: 475-481.
- Lopez-Velez M; Martinez F & Del Valle-Ribes C (2003). The study of phenolic compounds as natural antioxidants in wine. *Crit. Rev. Food Sci. Nutr.* 43:233-244.



- Matkowski A (2008). Plant *in vitro* culture for the production of antioxidants-A review. *Biotechnology Advances* 26: 548-560.
- Mattivi F; Guzzon R; Vrhovsek U; Stefanini M & Velasco R (2006). Metabolite profiling of grape: Flavonols and anthocyanins. *J Agr Food Chem.* 54(20): 7692-702.
- Mihai R; Brezeanu A & Cogalniceanu G (2009). Aspects of some elicitors influence on nonmorphogenic callus of *Vitis vinifera* var. Isabelle. *Romanian Biotechnological Letters* 14: 4511-4518.
- Mihai R; Mitoi M; Brezeanu A & Cogalniceanu G (2010). Two-stage system, a possible strategy for the enhancement of anthocyanin biosynthesis in a long-term grape callus cultures. *Romanian Biotechnological Letters* 15: 5026-5033.
- Moreno J & Peinado R (2012). Must aromas, In: *Enological Chemistry*, Academic Press, p 429. Spain.
- Murashige T & Skoog F (1962). A revised medium for rapid growth and bioassays with tobacco tissue cultures. *Physiol. Plant.*15: 473-497.
- Mullins M G; Bouquet A & Williams L E (1992). *Biology of Grapevine*. Cambridge University Press, Cambridge. 239.
- Nakano M; Sakakibara T; Watanabe Y & Mii M (1997). Establishment of embryogenesis cultures in several cultivars of *Vitis vinifera* and *V. labruscana*. *Vitis* 36:141-145
- Oğuz D; Keskin N & Özdemir FA (2020). Induction of Anthocyanin Accumulation in Callus Culture of 'Karaerik' (*Vitis vinifera* L.) by Ultraviolet Irradiation Effect *Turkish Journal of Agricultural Research* 7: 96-104.
- Oskay D & Oskay M (2009). Bitki sekonder metabolitlerinin biyoteknolojik önemi. *E-Journal of New World Sciences Academy* 4 (2): 31-41.
- Pichersky E & Raguso R A (2018). Why do plants produce so many terpenoid compounds? *New Phytol.* 220: 692-702.
- Rienth M; Vigneron N; Darriet P; Sweetman C; Burbidge C; Bonghi C; Walker RP; Famiani F & Castellarin SD (2021) Grape Berry Secondary Metabolites and Their Modulation by Abiotic Factors in a Climate Change Scenario-A Review. *Front. Plant Sci.* 12:643258.
- Rühmann S (2005). Induktion von Sekundärstoffen in *Vitis vinifera* Kalluskulturen durch Hefe-Elicitoren. Ph.D. Thesis. Technische Universität München-Weihenstephan, Department für Pflanzenwissenschaften, Fachgebiet Obstbau, München-Weihenstephan, Germany, 207 pp.
- Schenk R V & Hildebrandt A C (1972). Medium and Techniques for Induction and Growth of Monocotyledonous and Dicotyledonous Plant Cell Cultures. *Canadian Journal of Botany*, 50, 199-204.

- Soleas G J; Diamandis E P & Goldberg D M (1997). Resveratrol: a molecule whosetime has come? And gone? Clin Biochem 30, 91-113.
- Sökmen A & Gürel E (2001). Sekonder Metabolit Üretimi. (Editörler Babaoğlu M; Gürel E & Özcan S), Bitki Biyoteknolojisi Cilt I Doku Kültürü ve Uygulamaları, S.Ü. Vakfı Yayınları, Konya, 211-261.
- Tanur-Erkoyuncu M & Yorgancılar M (2016). Bitki doku kültürü yöntemleri ile sekonder metabolitlerin üretimi. Selçuk Tar Bil Der, 2: 66-76.
- Tamura H; Kumaoka Y & Sugisawa H (1989). Identification and quantitative variation of anthocyanins produced by cultured callus tissue of *Vitis* sp. Agricultural and Biological Chemistry 53(7): 1969-1970
- Topcu Ş & Çölgeçen H (2015). Bitki Sekonder Metabolitlerinin Biyoreaktörlerde Üretilmesi. Türk Bilimsel Derlemeler Dergisi (2): 9-29.
- Torregrossa L; Torres-Vials M & Bouquet A (1995). Somatic embryogenesis from leaves of *Vitis muscadinia* hybrids. Vitis 34: 239-240.
- Vanisree M & Tsay H S (2004). Plant cell cultures- an alternative and efficient source for the production of biologically important secondary metabolites. International Journal of Applied Science and Engineering 1: 29-48.
- Verpoorte R Contin A & Memelink J (2002). Biotechnology for the production of plant secondary metabolites. Phytochemistry Reviews 1: 13-25.



## CHAPTER 8

# AN IMPORTANT VALUE ‘KARAERİK’ GRAPE CULTIVAR (*VITIS VINIFERA* L.): AN OVERVIEW OF IT WITH STUDIES IN THE LIGHT OF LITERATURE

Ozkan KAYA<sup>1✉</sup> & Cafer KOSE<sup>2</sup> & Nalan Nazan KALKAN<sup>3</sup>  
Tevhit GECİM<sup>4</sup> & Birol KARADOĞAN<sup>5</sup> & Abdurrahim BOZKURT<sup>6</sup>

<sup>1</sup>(Assoc. Prof. Dr.), Erzincan Horticultural  
Research Institute, 24060 Erzincan, Türkiye,  
e-mail: kayaozkan25@hotmail.com

 0000-0002-1679-6125

<sup>2</sup>(Prof. Dr.), Atatürk University, Faculty of Agriculture,  
Department of Horticulture, 25240 Erzurum, Türkiye,  
e-mail: ckose@atauni.edu.tr.

 0000-0002-4354-0643

<sup>3</sup>(M.Sc. Agr. Eng.), Erzincan Horticultural  
Research Institute, 24060 Erzincan, Türkiye,  
e-mail: nalannazan.kalkan@tarim.gov.tr

 0000-0002-9204-7281

<sup>4</sup>(M.Sc. Agr. Eng.), Erzincan Horticultural  
Research Institute, 24060 Erzincan, Türkiye,  
e-mail: tevhit.gecim@tarimorman.gov.tr.

 0000-0003-2406-9929

<sup>5</sup>(M.Sc. Agr. Eng.), Erzincan Horticultural  
Research Institute, 24060 Erzincan, Türkiye,  
e-mail: birol.karadogan@tarimorman.gov.tr

 0000-0002-1526-1751

<sup>6</sup>(M.Sc. Agr. Eng.), Erzincan Horticultural  
Research Institute, 24060 Erzincan, Türkiye,  
e-mail: abdurrahimbozkurt@hotmail.com

 0000-0001-7315-202X

## 1. Introduction

Viticulture in Türkiye is a highly productive cultural plant that can maintain its economic production level in ecologically very different regions. From this perspective, Türkiye is among the regions with the most favorable climate for viticulture and is known as the gene center of the grapevine, and therefore it has an old and deep-rooted viticulture culture. The contribution of grapes to national income in the country's economy is high, and it is evaluated in different ways according to the characteristics of berry or cultivars. It is a berry useful for our nutrition and health, as it contains vitamins A, B, C, nitrogenous substances, glucose, iron, calcium, potassium, and sodium in its structure (Çelik *et al.*, 1998). Another important feature of viticulture is that it enables the use of barren and inclined areas that are not suitable for the cultivation of other agricultural products. Indeed, grapevine can usually be grown in the whole of Türkiye, except for the high parts of the Central and Eastern Anatolia Region and the coastline of the Black Sea Region (Doganay 1995). The most grape growing area and production regions in Türkiye are the Aegean, Mediterranean, Mid-South, Southeast, Northeast, and Black Sea regions, respectively. In fact, the Northeast Anatolian agricultural region, in which Erzincan is within located, is relatively far from the features that can respond to the ecological demands of the grapevine. However, the availability of natural environmental conditions in and around the Erzincan plain plays a key role in the execution of viticulture and fruit growing activities.

The Eastern Anatolia Region, where the continental climate is dominant, has microclimate characteristics, and Erzincan is the most important province in terms of economic viticulture potential in the Northeast Agricultural Region (Karadoğan & Keskin 2017; Kaya & Kose 2020). In this province, viticulture is carried out on an area of approximately 9000 decares and the production amount is 6000 tons/year for many years (Kaya & Köse 2017). The only standard cultivar of the North-East Agricultural Region, 'Karaerik' (*Vitis vinifera* L.) (syn. Cimin) grape cultivar (Figure 1) plays a key role in Erzincan viticulture and it is grown in 90-95% of the vineyards in the province. It has been widely grown as table grapes in the town of Üzümlü and its surroundings/towns (Bayırbağ, Göller, Pişkidağ, Karakaya, Çadırtepe) of the city of Erzincan for years and has a high market value (Güneş *et al.*, 2015; Köse *et al.*, 2018). The taste of berries of this grape cultivar lies on a fine point between mildly sweet and sour with a specific aroma not found in other *V. vinifera* grape cultivars (Kalkan *et al.*, 2012). Although it is generally used as a table grape it can also be preferred in the form of dried pulp, vinegar, and molasses (Hermosín-

Gutiérrez *et al.*, 2019). In addition, the leaves are widely used as fresh and in brine (Akpınar & Yiğit 2006). A traditional product called 'Saruç' has been produced from this grape cultivar since ancient times in the region (Kalkan *et al.*, 2012). Due to the positive characteristics of all these, there has been an increasing interest in the export of this grape cultivar recently (Hermosín-Gutiérrez *et al.*, 2019).

Numerous studies have previously been published regarding the physiological, ampelographic properties, nutritional value, phenolic composition, antioxidant capacity, frost tolerance, cold hardiness, pruning, and training systems of this grape cultivar, which is very valuable for the region (Köse 2002; Akpınar & Yiğit 2006; Köse & Gülerüz 2007; Kalkan *et al.*, 2012; Güneş *et al.*, 2015; Keskin *et al.*, 2015; Kaya & Köse 2017; 2020; Karadoğan & Keskin 2017; Buztepe *et al.*, 2017; Köse & Kaya 2017; Kalkan & Keskin 2018; Keskin 2018a; Keskin 2018b; Keskin & Kunter 2018; Karadoğan *et al.*, 2018; Köse *et al.*, 2018; Kurt *et al.*, 2018; Rende *et al.*, 2018; Hermosín-Gutiérrez *et al.*, 2019; Kaya 2019; 2020; Çelik *et al.*, 2020; Oğuz *et al.*, 2020). In this study, the results of the data obtained from different studies on 'Karaerik' grape cultivar were discussed by reviewing the literature, and therefore, we hope that these results will provide new insights into how it may influence strategies to increase cultivation and production of this cultivar in later years.



**Figure 1.** 'Karaerik' grape cultivar (Photo: N N Kalkan).

## 2. Research about 'Karaerik' grape cultivar

### 2.1. Clone selection

The first clone selection study for the 'Karaerik' grape cultivar was initiated by the Erzincan Horticultural Research Institute and the project was completed in three stages. The selection of the first clone candidates was started in the growers' vineyards in the Üzümlü region, where the 'Karaerik' grape cultivar was widely grown between 1982-1988. The second phase of the study, the 'Clone Collection Vineyard', was established with the cuttings taken from the 40 selected clone vine candidates. At the end of the study, the clone candidates were evaluated according to their weighting ranking score, and finally, the six clones with the highest score (clone 23, 18, 19, 3, 13, 15, and 30) were selected for the 'Karaerik' grape cultivar. Then, 'Clone Comparison Vineyard' was established with these clone candidates. As a result of selection, clones 23 and 18 were selected because they showed the highest performance as table grapes (Karadoğan *et al.*, 2014). The second clone study for this grape cultivar was carried out within the scope of a doctoral thesis and was completed in 2002 (Köse 2002). The research was carried out in Üzümlü, Bayırbağ and Pişkidağ regions of Erzincan province between 1999-2001. In the study, 22 clones (24 Ü-KE 83, 24 Ü-KE 213, 24 Ü-KE 317, 24 Ü-KE 325, 24 P-KE 407, 24 P-KE 410, 24 P-KE 425, 24 P-KE 1585, 24 Ü-KE 490, 24 P-KE 432, 24 Ü-KE 451, 24 Ü-KE 489, 24 Ü-KE 460, 24 P-KE 1823, 24 Ü-KE 477, 24 Ü-KE 500, 24 P-KE 521, 24 Ü-KE 971, 24 P-KE 1590, 24 Ü-KE 306, 24 P-KE 1833 ve 24 P-KE 1987), with a score of 650 and above were selected from among 200 clone vine candidates according to weighting ranking score.

### 2.2. Ampelography

The first ampelography study carried out on this grape cultivar was in 1968 and it was determined that there were two types of 'Karaerik': ellipsoidal and round (İştar 1968). For this grape cultivar, the shoot tip is yellowish-green, with sparse felt hairs. Shoots are rounded, often corrugated, distinctly leathery, sparsely hairy. The mature leaf is thin, straight, less wavy, deep five-part, slices are prominent. The upper color of the leaf is bright green, the lower color is matte green. Both the upper and lower parts of the leaf are sparsely hairy. The petiole is of medium thickness, round, and sparsely hairy. It has U and V-shaped petiole sinus. The shape of the cluster is largely clustered, branched cone, medium density, homogeneous, and the berries are large. The peduncle is of medium length, brittle, its upper side is brown, the lower side is greenish-red,



and the cluster weight is 450-550 grams. Berry is ellipsoidal and round shape, its color is violet-black (Çelik 2006). The skin of the berry is quite thick, crunchy, easily trampled in the mouth, has a light aroma and a tannin taste. In addition, the peels of mature berries crack easily. Berry pulp is juicy, crispy pulp, lightly flavored, the mesocarp is not thick but hard, whereas endocarp is thick and loses flesh. The number of seeds per berry is 1-3. The berries are of good quality for table use and have a medium sweetness and mild aroma. In addition, the average weight of a hundred berries is 712 grams (İştar 1968).

### 2.3. Cold hardiness

Many studies have been carried out on the cold hardiness of dormant buds in 'Karaerik' grape cultivar (Köse & Güleriyüz 2009; Kaya & Köse 2017; Kalkan *et al.*, 2017; Köse & Kaya, 2017; Buztepe *et al.*, 2017; Köse *et al.*, 2018; Rende *et al.*, 2018; Kaya & Köse 2020; Kaya 2020). Indeed, Köse & Güleriyüz (2009) reported that frost damage occurred at a rate of 64% in dormant primary buds of 'Karaerik' grape cultivar after temperatures dropped to -22.2°C following 2017-18. Besides, Kaya and Köse (2017) determined that the presence of nodes with lateral shoots affected the frost tolerance of primary buds. They found that buds in nodes without lateral shoots showed HTE and LTE at lower temperatures (HTE mean -7.9 °C and LTE mean -11.5 °C) than buds (HTE mean -6.7 °C and LTE mean -8.3 °C) in nodes with lateral shoots. Based on these results, the researchers suggested that the lateral shoots of the vines should be cut with summer pruning in areas damaged by low temperatures. In a different study was conducted to determine the frost damage of dormant buds according to different trunk heights (75, 100, and 125cm) in 'Karaerik' grape cultivar grown in Erzincan province following the winter cold of 2012/13. As a result of the study, it has been suggested that 125 cm stem height is more suitable in terms of the winter cold hardiness of dormant buds for viticulture in the region (Kalkan *et al.*, 2017). In studies for 'Karaerik' grape cultivar on the cold hardiness of dormant buds according to the node position on the shoot, it was reported that the buds in the basal nodes were more tolerant than the apical buds (Buztepe *et al.*, 2017; Köse & Kaya 2017). A study conducted to determine the effects of boron (Bio-B) and plant growth-promoting bacteria (PGPR) on frost damage in this grape cultivar showed that Bio-B application increased frost resistance (Köse *et al.*, 2018). Additionally, determining the low-temperature hardiness of the dormant buds taken on six different sampling dates of the 'Karaerik' grape cultivar covering the acclimation, hardening, and deacclimation stages in the winter period of 2015/16 and the relationship between tolerance and biochemical

parameters were investigated. In the study, high and low-temperature exotherms were determined in the primary buds, and the relationship between tolerance levels was determined by lipid peroxidation, total carbohydrate, total water-soluble protein, peroxidase, hydrogen peroxide, and siglent oxygen analyzes of these buds (Rende *et al.*, 2018). On the other hand, in a study in which the effect of rapid temperature changes on frost resistance was tried to be determined, the grape cultivar 'Karaerik' was used. Based on the results of the study, it was stated that rapid temperature changes (4.00°C) changed cold hardiness in dormant buds. To achieve consistent LTE results and reliability at DTA tests, it was decided that buds should be brought into the lab by keeping the temperatures at the sampling time, prepared for DTA analyzes at these temperatures, and starting DTA analyzes from these temperatures is the right test (Kaya & Kose 2020). In addition to these studies, an interesting study was conducted on whether removing the first five leaves at the base of the shoot changes the bud cold hardiness. The results showed that the adoption of defoliation in cool climates has no adverse effects on the survival of basal buds, but may instead improve the survival of apical ones is of particular interest concerning this grape cultivar with poor basal bud fruitfulness (Kaya 2020). In the light of the above studies, we can say that the  $LT_{50}$  value of the dormant buds of the 'Karaerik' grape cultivar was -18°C, while the  $LT_{100}$  values of the buds were determined as -25°C.

#### 2.4. Chemical properties

Sat *et al.*, (2002) reported the suitability of canned and fresh (unprocessed) 'Karaerik' cultivar grape leaves to prepare Sarma, a traditional Turkish dish. Based on the physical and chemical analysis findings, the results showed that the quality of the 'Karaerik' leaves was better than the leaves of some grape cultivars. The sensory evaluation also showed that 'Karaerik' grape cultivar was the most suitable grape leaf for making Sarma food.

The physical, chemical, and phytochemical properties of the clones of the 'Karaerik' grape cultivar were examined and differences between clones were determined in terms of these properties. Clone 30 in terms of cluster weight, clone 23 for color characteristics, clone 13 and clone 15 for berry size and berry width, clone 19 for the total soluble solids (TSS) content, clone 15 for berry weight, clone 13 also for organic acid and clones 15 also for macro-micro-nutrient content have been the prominent clones. Except for catechin, there also was no difference in phenolic compound content between clones (Karadoğan & Keskin 2017). In the study of Keskin (2018a), the *trans*-resverarol production potential of 'Karaerik' clones ranged from 77.78  $\mu\text{g kg}^{-1}$  to 57.01  $\mu\text{g kg}^{-1}$  (fresh

weight) and there is no significant difference among the mean values of the clones.

Hermosín-Gutiérrez *et al.*, (2019) has been reported in connection with a detailed characterization of the anthocyanin composition of 'Karaerik' berries and the determination of the antioxidant capacity value of the phenolics found in the skin and berry. Anthocyanin (1.66 and 7.48 g mv-3-glc equivalent kg<sup>-1</sup> fresh weight) contents and total phenolic compounds (average 2.88 and 8.56 g gallic acid equivalent kg<sup>-1</sup> fresh weight) varied significantly in the whole berry and the skin. It was determined that malvidin-based anthocyanins made the highest contribution to the pigment content of the berry, and also malvidin-3-glucoside (mv-3-glc), the main anthocyanin in the skin (average 42.08% mol) and the whole berry (39.98 mol%). Total phenolic content and oxygen radical absorbance capacity were also reported by the same researchers to evaluate the antioxidant properties of this grape cultivar. They identified numerous non-anthocyanin phenolic compounds in the seeds and skins of this grape, including several monomeric, eleven flavonols, two stilbenes, six hydroxycinnamic acid derivatives, proanthocyanidin, and dimeric flavan-3-ols. The derivatives that dominate the flavonol profile of grape skins were quercetin type, followed by myricetin type. The main hydroxycinnamic acid derivatives of this cultivar were identified as tartaric acid esters of three acids (ferulic, coumaric, and caffeic acids). Quantitative and qualitative differences in flavan-3-ols composition were observed between berry tissues. Proanthocyanidins, mainly found in seeds, were the most abundant phenolic compound class in this cultivar. Higher antioxidant capacity values related to total phenolic content were determined in berry seeds (Pérez-Navarro *et al.*, 2021). On the other hand, research has also been conducted on the nutritional value of this grape berry to determine its health benefits and potential economic. The most abundant sugars in the berry of this grape cultivar were glucose and fructose (peel/whole berry; averages from 183.36 to 108.60 g kg<sup>-1</sup> and from 236.57 to 127.87 fresh weight, respectively), while the major organic acids were malic and tartaric acids (between 2.61 to 1.76 and between 7.17 to 2.81 g kg<sup>-1</sup> fresh weight, respectively). Linoleic acid (seed/whole berry/peel; 57.83, 33.12 and 37.14%, respectively) was the predominant fatty acid, while potassium (seed/whole berry/peel; 5354, 10226.33 and 9331.5 µg/g dry weight, respectively) was the predominant mineral, followed by phosphorus (3072.67 and 1592.8, 2672) in grape the berry. Their findings showed that the nutritional components and physicochemical parameters of this grape cultivar varied significantly between different tissues (seed, whole berry, and peel) of the grape (Kurt *et al.*, 2018).

## 2.5. *Traditional foods*

This grape cultivar, which is generally consumed as a table, is also used in human nutrition in the form of products obtained by processing grape must in different ways (vinegar, molasses, sausage, pulp, bastik, meatballs, etc.). Additionally, a product called Saruç, which is a traditional product that is dried by hanging on a rope and then offered for consumption after the walnuts are placed into the grapes that are cut into two, has been made from the 'Karaerik' grape cultivar since ancient times in the region. With its high nutritional content and a special aroma, the product, which is in high demand in the region, can find buyers at a very higher price. In studies on Saruç, its pH, ash content, total soluble solids (TSS), dry matter, moisture, and skin color values and chemical properties (total acidity, protein, N, P, K, Ca, Mg, S, Fe, Zn, Cu, Na) was detected. Based on the results of the study, it was determined that 185 g of raisins were obtained from one kg of fresh grapes, and 1 kg of Saruç consisted of 685 g of raisins and 315 g of walnuts. In addition, according to the results of the analysis, the pH, TSS, protein, P, Ca, Cu values of the obtained Saruç were found to be 3.13, 5.77%, 7.48%, 225.20 mg, 59.40, Cu 0.66 mg, respectively (Kalkan *et al.*, 2012). On the other hand, though it is known that vinegar and molasses are made from this grape cultivar in the region, studies on this subject have not been found in the literature.

## 2.6. *Improving the grape quality*

In this context, the effects of two different organic biostimulants containing mineral and organic compounds (seaweed-based) on the grape quality of 'Karaerik' grape cultivar were investigated by Köse & Gülyüz (1999) in field conditions. Both mineral and organic compounds have been reported to reduce TSSC and reducing sugars in the must and total dry matter of the berry. Compared to the control, the effects of biostimulator applications decreased the rate of fruit falling in all treatments and all of these applications showed similar effects. In addition, while Proton application did not have an effect on the spilled berry rate in the study, it was determined that Maxicrop applications other than 1250 mg kg<sup>-1</sup> reduced the spilled berry rate (Köse & Gülyüz 1999). On the other hand, three grapevine training systems (vertical shoot positioning-shaped, Y-shaped and traditional Baran system) and three different (75, 100, and 125 cm) trunk heights were compared for their effects on skin color, berry weight, cluster weight (g), TA%, pH, TSS%, MI, organic acid, sugar, antioxidant activity (FRAP) and vitamin C as well as total and individual phenolic compounds

(Kalkan & Keskin 2018) and *trans*-resveratrol (Keskin & Kunter 2018) in *Vitis vinifera* L. cv. 'Karaerik'. These studies indicated that various trunk heights and grapevine training systems had no significant effect on the content of h, b\*, berry weight, cluster weight, TA%, pH, MI, TSS%, sugar, macro-micro nutrients, organic acid, and individual phenolic compound, however, except for *trans*-resveratrol content, effects on the density of saturation (c) and color (a\*), total phenolic content and antioxidant activity were significant. Moreover, a study was conducted by Köse *et al.* (2015), as Boron (B) deficiency, which is common in Erzincan vineyards, can affect the production and quality of the vine (*Vitis vinifera* L. cv. 'Karaerik'). A field experiment in the study was carried out for determining critical soil test, tissue B values, and the optimum economic B rate (OEBR) for quality and yield response of vines to B fertilizer application method (soil and foliar) at 5 doses (12, 9, 3, 1 and 0 kg, B/ha). OEBR of soil and foliar treatment ranged from 20.2 to 12.8 t/ha with an average yield of 6.4 to 8.5 kg B/ha, respectively. The average soil B content in the OEBR ranged from 0.32 to 2.52 mg/kg. Berry B content amounted to 12.9 and 21.4 mg/kg, and leaf tissue B content amounted to 98.9 and 64.4 mg/kg for soil and foliar treatments, respectively. Regardless of the treatment method, it was determined that B application decreased Fe, Mn, and Cu content while increasing tissue N, Ca, Mg, P, K, and Zn. As a result of the study, it was concluded that an addition of 6.4 kg/ha for foliar boron application and 8.5 kg/ha for soil boron application is sufficient to increase the B level in the soil to levels that are not deficient (Köse *et al.*, 2015). In a different study, Kaya (2019) conducted a study on the presence of side shoots, yield, cluster characteristics, and bud fertility in this grape cultivar of manual leaf removal (fruit-zone five-leaf removal by hand) at pre-bloom, flowering, berry set stages. Based on the phenological stage, fruit-zone leaf removal by hand, reduced yield, cluster weight, berry cracking, number of berries per cluster, cluster compactness, total acidity while berry composition, and maintaining bud fruitfulness as compared with control treatment. Removal of five leaves per shoot in all treatments increased berry weight per cluster, cluster width and length, and soluble solid accumulation as compared with the control. According to the results of the study, the researcher suggested that removing the first five leaves at the base of the shoot pre-bloom can improve the grape quality characteristics of this grape cultivar (Kaya 2019).

## 2.7. Other studies

A study was conducted on the effect of ultraviolet (UV) irradiation on total and individual phenolic formation induction in callus cultures of 'Karaerik' grape

cultivar. In the study, Gamborg B-5 was used as a culture medium with 0.1 mg L<sup>-1</sup> NAA (Naphthalinacetic acid) and 0.2 mg L<sup>-1</sup> Kin (Kinetin), and callus tissues were obtained from the leaves of cuttings grown *in-vitro*. Callus tissues, which were subcultured twice with 21-day intervals, were exposed to 254 nm UV-C light at a distance of 10 cm from the source for 10 and 15 min in Petri dishes in a sterile cabinet after the second subculture. After application, callus tissues were incubated in dark conditions and their phenolic compounds were measured at 24, 48, and 72 hours. Based on the results of the study, it can be said that UV irradiation is effective in inducing the formation of phenolic compounds in the callus tissues of this grape cultivar, and this effect is closely related to the treatment time (Çelik *et al.*, 2020). In another study, the effect of 'Karaerik' grape cultivar on the stimulation of anthocyanin production in callus cultures after exposure to ultraviolet (UV) radiation was determined. The method described by Çelik *et al.*, (2020) was used for grape cultivar, and according to the results, it was determined that UV radiation stimulated anthocyanin production in the tissues of this grape cultivar (Oğuz *et al.*, 2020). On the other hand, there are studies on the post-harvest preservation of the 'Karaerik' grape cultivar (Güleryüz & Çeleçi 1988; Karadoğan *et al.*, 2005; Keskin *et al.*, 2015). In these studies, sulfur dioxide (SO<sub>2</sub>) generators were applied to 'Karaerik' grape cultivar and their effects on quality and storability were investigated. According to the analyzes and observations made at the end of each month on grapes stored at -1 - 0°C temperature and 87-92% relative humidity for three months, the controls did not last even until the end of the first month and rotted, cracked and lost their marketing quality. Although the best preservation is provided with two-stage American fumigant papers, the application of bags has been deemed more appropriate for the region, as it is cheap, easy to obtain, and provides a level of preservation close to the two-stage American fumigant papers (Güleryüz & Çeleçi 1988). In another study, the effectiveness of hot water application was researched on the rooting of the cuttings and breaking of dormant buds of the 'Karaerik' grape cultivar. The basal and apical parts of the cuttings were exposed to 60°C hot water for 5 min and the rooting of the cuttings was considerably delayed compared to the control. Additionally, by exposing the apical part of the cutting to hot water, bud break was delayed, whereas by exposing the basal part of the cutting to hot water, bud break was early (Odabaş 2010). Keskin *et al.* (2015) determined the effects of hot water (55°C for 5 min) and UV-C applications (254 nm wavelength from 100 (0.25 kJ/m<sup>2</sup>) cm distance for 4 minutes) for protection of fruit quality and prevention of decay as well as extension of storage period in Karaerik cultivar. All clusters were stored at 0±

1°C and 90 ± 5% relative humidity conditions in the cold storage room. As a result of the study, by covering with stretch film, clusters of Karaerik cultivar subjected to hot water and UV-C have been stored for 90 days.

### 3. Conclusion

The present work represents the first research dealing with the detailed previous work from *V. vinifera* grape, 'Karaerik'. In this regard, information on previous studies for 'Karaerik' grape cultivar, which is an important genetic resource for the Erzincan region, has been compiled in the light of literature. Based on the results of the research, it can be said that many studies have been carried out for this cultivar such as cold hardiness of dormant buds, ampelographic studies, post-harvest storage, yield increase, defoliation applications, training systems, pruning, chemical and fertilizer application, physiological properties, different usage patterns of berries, biochemical parameters, nutrient contents, clone studies, hot water application to cuttings. All these studies indicated that the 'Karaerik' grape cultivar is an important table grape cultivar for Erzincan, as well as having a very rich nutritional content for human nutrition. In addition, the problems that cause significant yield losses in terms of viticulture in the region have been investigated by various researchers and the results for the solution of these problems have been brought to both the producers and the scientific community. To sum up, we believe that if the practical information gathered here is used and applied, it can be of vital importance for the development of viticulture in the region.

### References

- Akpınar E & Yiğit D (2006). Ekolojik Faktorlerin Karaerik Üzüm Çeşidi Yetiştiriciliğine Etkileri. Doğu Coğrafya Dergisi, 11 (16): 39-61
- Buztepe A; Kose C & Kaya O (2017). Evaluation of cold tolerance of dormant buds according to position using thermal analysis in 'Karaerik' (*V. vinifera* L.) grape. *Int J Res Rev*, 4 (10): 38-45
- Çelik H (2006). Üzüm Çeşit Kataloğu ( Grape Cultivar Catalog). Sunfidan A.Ş. Mesleki Kitaplar Serisi:3, Ankara, 165 s.
- Çelik M; Keskin N & Özdemir F A (2020). The effects of UV irradiation and incubation time on *in vitro* phenolic compound production in 'Karaerik' grape cultivar. *Turkish Journal of Forest Science*, 23 (6): 1428-1434
- Çelik H; Ağaoğlu Y S; Fidan Y; Marasalı B & Söylemezoğlu G (1998). Genel Bağcılık Sunfidan A.Ş. Mesleki Kitaplar Serisi No: 1 253s, Ankara



- Doganay H (1995). Türkiye Ekonomik Coğrafyası, Öz Eğitim Yayınları: 6, İstanbul, s. 186
- Güleryüz M & Celepçi M (1988). Kükürt Dioksit Gazı İle Kasa İçi Fumigasyonunun Karaerik Üzüm Çeşidinin Muhafaza Süresine Etkisi Üzerinde Bir Araştırma. Atatürk Üniversitesi Ziraat Fakültesi Dergisi 19: 1-4
- Güneş A; Köse C & Turan M (2015). Yield and mineral composition of grapevine (*Vitis vinifera* L. cv. 'Karaerik') as affected by boron management. Turkish Journal of Agriculture and Forestry, 39 (5): 742-752
- Hermosín-Gutiérrez I; Gómez-Alonso S; Pérez-Navarro J; Kurt A; Colak N; Akpınar E... & Ayaz FA (2020). *Vitis vinifera* Turkish grape cultivar 'Karaerik'. Part I: anthocyanin composition, and identification of a newly found anthocyanin. Journal of the Science of Food and Agriculture, 100 (3): 1301-1310
- İştar A (1968). Erzincan Merkez İlçesinde Yetiştirilen Üzüm Çeşitlerinin Ampelografileri ile Kuru Madde Asit Analizleri Üzerinde Bir Araştırma. Atatürk Üni. Zir, Fak. Zirai Araştırma Enstitüsü Araştırma Bülteni No: 33
- Kalkan N N & Keskin N (2018). The effects of trunk height and training systems on the some physicochemical properties of 'Karaerik' berries. Yuzuncu Yıl University Journal of Agricultural Sciences, 28 (Special Issue): 257-267
- Kalkan N N; Kaya Ö; Karadoğan B & Köse C (2017). Determination of cold damage and lipid peroxidation levels of 'Karaerik' (*Vitis vinifera* L.) grape cultivar having different trunk heights in winter buds. Alinteri Zirai Bilimler Dergisi, 32: 11-17
- Kalkan N N; Öz MH & Cangi R (2012). Saruç'un Üretim Tekniği ve Bazı Fiziksel-Kimyasal Özelliklerinin Belirlenmesi. Gıda ve Yem Bilimi Teknolojisi Dergisi, 1: (11-17)
- Karadoğan B & Keskin N (2017). Karaerik (*Vitis vinifera* L. cv. 'Karaerik') Klonlarının Kalite ve Fitokimyasal Özellikleri. Türk Tarım ve Doğa Bilimleri Dergisi, 4(2): 205-212
- Karadoğan B; Kalkan NN; Albayrak S & Öz M H (2014). Karaerik Üzüm Çeşidinde Klon Seleksiyonu. TAGEM 11-336-3-590 No'lu Proje Sonuç Raporu. 37 s. Erzincan
- Karadoğan B; Keskin N; Kunter B; Dilhem O & Kalkan N N (2018). 'Karaerik' (Cimin) Klonlarının Toplam Fenolik Ve Antioksidan İçerikleri Bakımından Karşılaştırılması. Bahçe, 47 (Özel Sayı 1): 117-120
- Karadoğan B; Albayrak S Öz M H & Öz E (2005). Karaerik üzüm çeşidinde farklı katı SO<sub>2</sub> generatörlerinin muhafaza süresi ve kalite kayıpları üzerine etkilerinin araştırılması. Türkiye 6. Bağcılık Sempozyumu, 168-178


- Kaya O & Kose C (2020). How Pretest Temperatures Change the Cold Hardiness of Grapevine (*Vitis Vinifera* L. cv. 'Karaerik') Dormant Buds?. *International Journal of Fruit Science*, 20: S1470-1482
- Kaya Ö (2019). Effect of manual leaf removal and its timing on yield, the presence of lateral shoots and cluster characteristics with the grape cultivar 'Karaerik'. *Mitteilungen Klosterneuburg, Rebe und Wein. Obstbau und Früchteverwertung*, 69 (2): 83-92
- Kaya O (2020). Defoliation alleviates cold-induced oxidative damage in dormant buds of grapevine by up-regulating soluble carbohydrates and decreasing ROS. *Acta Physiologiae Plantarum*, 42: 1-10
- Kaya Ö & Köse C (2017). Determination of resistance to low temperatures of winter buds on lateral shoot present in 'Karaerik' (*Vitis vinifera* L.) grape cultivar. *Acta Physiologiae Plantarum*, 39 (9); 1-9
- Keskin N (2018a). 'Karaerik' (*Vitis vinifera* L.) Klonlarının Resveratrol Üretim Potansiyeli. V. Uluslararası Multidisipliner Çalışmaları Kongresi Bildiri Kitabı, s:376-382
- Keskin N (2018b). 'Karaerik' Üzüm Çeşidinin *in vitro* Rejenerasyon Potansiyelinin Belirlenmesi. Ziraat Bilimlerinde Güncel Akademik Çalışmalar-2018 (Ed. Keskin N), Stamparija Ivpe, Cetinje, pp.75-82
- Keskin N; Keskin S; Çavuşoğlu Ş; Şevgin N; Kunter B; Karadoğan B & Kalkan N N (2015). 'Karaerik' (Cimin) Üzüm Çeşidinde Hasat Sonrası UV-C Ve Sıcak Su Uygulamalarının Meyve Kalitesi Ve Soğukta Muhafaza Üzerine Etkileri. GAP VII. Tarım Kongresi Bildiri Kitabı, s:34-40
- Keskin N & Kunter B (2018). 'Karaerik' Üzüm Çeşidinde Farklı Terbiye Şekli ve Gövde Yüksekliğinin Resveratrol İçeriği Üzerine Etkisi. Ziraat Bilimlerinde Güncel Akademik Çalışmalar-2018 (Ed. Keskin N), Stamparija Ivpe, Cetinje, pp.43-49
- Köse C & Gülerüz M (1999). Effects of some organic biostimulants on the quality of table grapes. In *Improved Crop Quality by Nutrient Management* (pp. 215-218). Springer, Dordrecht.
- Köse C & Gülerüz M (2009). Frost damage in dormant buds of 'Karaerik' grapevine grown at Üzümlü province of Erzincan during the winter of 2007-2008. *Ziraat Fakültesi Dergisi, Atatürk Üniversitesi*, 40 (1): 55-60
- Köse C & Kaya Ö (2017). Determination of resistance to low temperatures of winter buds according to position in 'Karaerik' (*V. vinifera* L.) grape cultivar. *International Journal of Scientific and Research Publications*, 7 (4): 4-5
- Köse C (2002). Karaerik üzüm çeşidinin klon seleksiyonu ile ıslahı üzerine bir araştırma, Atatürk Üniversitesi Fen Bilimleri Enstitüsü, 213 s. Erzurum


- Köse C; Güneş A; Kaya Ö; Kıtır N; Turan M & Şahin F (2018). Freeze injure and antioxidant enzyme activity of grapevine (*Vitis Vinifera*) under bio-boron fertilizer applications. *Erwerbs-Obstbau*, 60 (Sub1): 3-10
- Kurt A; Colak N; Bengü A Ş; Gündoğdu A; Akpınar E; Hayırlıoğlu-Ayaz S & Ayaz F A (2018). A Nutritional Evaluation of the Berry of a New Grape: 'Karaerik' (*Vitis vinifera* L.). *International Journal of Food Studies*, 7: 98-116
- Odabaş F (2010). Sıcak Su Uygulamasının Asma Çeliklerinin Köklenmesi Ve Gözlerin Sürmesine Etkileri Üzerinde Bir Araştırma. *Atatürk Üniversitesi Ziraat Fakültesi Dergisi*, 13: (3-4)
- Oğuz D; Keskin N & Özdemir F A (2020). Induction of Anthocyanin Accumulation in Callus Culture of 'Karaerik' (*Vitis vinifera* L.) by Ultraviolet Irradiation Effect. *Türkiye Tarımsal Araştırmalar Dergisi*, 7 (1) : 96-104
- Pérez-Navarro J; Hermosín-Gutiérrez I; Gómez-Alonso S; Kurt-Celebi A; Colak N; Akpınar E ... & Ayaz F A (2021). *Vitis vinifera* Turkish novel table grape 'Karaerik'. Part II: non-anthocyanin phenolic composition and antioxidant capacity. *Journal of the Science of Food and Agriculture*. Accepted Author Manuscript. <https://doi.org/10.1002/jsfa.11416>
- Rende M; Kose C & Kaya O (2018). An assessment of the relation between cold-hardiness and biochemical contents of winter buds of grapevine cv. 'Karaerik' in acclimation-hardening-deacclimation phases. *Mitteilungen Klosterneuburg, Rebe und Wein, Obstbau und Fruchteverwertung*, 68 (2): 67-81
- Sat I; G; Sengul M & Keles F (2002). Use of grape leaves in canned food. *Pakistan Journal of Nutrition*, 1 (6): 257-262.

## CHAPTER 9

# GRAPE YIELD, QUALITY AND NUTRITIONAL STATUS OF ‘EARLY CARDINAL’ (*V. VINIFERA* L.) IN RESPONSE TO GROWTH SUBSTRATE AND FERTILIZER APPLICATIONS IN SOILLESS CULTURE

Mikail ATALAN<sup>1</sup> & Serpil TANGOLAR<sup>2✉</sup>

<sup>1</sup>(MSc) Department of Horticulture, Faculty of Agriculture,  
University of Cukurova, Adana, Türkiye  
 0000-0001-5226-9261

<sup>2</sup>(Prof.Dr.), Department of Horticulture, Faculty of Agriculture,  
University of Cukurova, Adana, Türkiye,  
e-mail: stangolar@cu.edu.tr  
 0000-0002-5563-1972

### 1. Introduction

Due to favorable ecological conditions, the coastal part of the Mediterranean region, for the production of early table varieties such as Early Sweet, Prima, Yalova incisi, Early Cardinal, Cardinal, Trakya İlkeren, Ergin Çekirdeksizi, Black Magic, and Victoria is important. These varieties ripen in the open field at the beginning of June in the region. Grapes are grown in the greenhouse for earlier grape maturation in the region (Tangolar 2016).

Greenhouse cultivating began with glass greenhouses established in Antalya for the first time in Türkiye. Then, in 1940-1960, rapid progress was conducted with the use of plastic greenhouses in Türkiye (Sevgican *et al.* 2000). Soilless farming is a technique widely applied in greenhouse cultivation. In this technique, materials such as perlite, zeolite, pumice, vermiculite, rock wool, sand, sawdust, peat, cocopeat (coconut fiber), and plant compost are used

for solid substrates culture (Tangolar *et al.* 2017; Kaya *et al.* 2018; Tangolar *et al.* 2019a). Different methods are applied, ranging from water cultures (food film technique, etc.) to water and nutrient solutions (Koral 2006).

Although soilless cultivation systems were initially developed for vegetable and ornamental plants, it has also been used in grape growing programs in recent years (Buttaro *et al.* 2012; Tangolar *et al.* 2019b; Tangolar *et al.* 2019c). It is known that the soilless cultivation technique is an important tool in eliminating the problems caused by rootstocks, giving water to vines more effectively, and controlling the yield and quality per unit area. When the soilless culture grape cultivation is considered together with greenhouse grape production, it appears to be a significant cultivation method with these advantages (Di Lorenzo *et al.* 2013). Today, reasons such as the increase in the world population day by day and the limited opportunity to expand the agricultural areas have brought it necessary to increase the product to be taken from the unit area in order to meet the food need. In this context, the most suitable plant nutrition and fertilization treatments applications for plants in cultivated agricultural areas are one of the most important cultural practices to increase yield per unit area.

On the other hand, world agriculture has entered a different path with the effect of the green revolution that emerged towards the end of the 20<sup>th</sup> century as well as the industrial revolution. It is aimed to increase the amount of product obtained from the unit area to meet the food needs of the world population, which is increasing every day with the green revolution. With the pesticides and fertilizers applied in line with this approach, the desired yield increase was achieved. However, it was understood that the applied fertilizers and pesticides had many negative effects on human health over time. On the other hand, these practices also paved the way for the deterioration of the soil's physical structure and nutrient balance and the occurrence of important environmental problems such as aridity and salinization. Due to such undesirable developments, increasing the possibilities of using alternative natural products that do not pose a risk to human and environmental health in plant nutrition has been brought to the agenda (Aksoy 2001). It is thought that it is inevitable that the use of cultivation techniques following the organic agriculture philosophy is among the important targets in soilless cultivation systems, whose share in agricultural production is increasing day by day. The feasibility of organic cultivation in soilless culture systems been reported for different plant species (Bozköylü & Daşgan 2010), and new researches are still continuing in this direction.

This study was carried out to determine the effects of an organic liquid worm fertilizer with two different nutrient solutions on plant growth, grape yield, and quality in soilless culture in cultivation environments consisting of cocopeat, zeolite, and their mixtures in different proportions.

## 2. Materials and Methods

This research was carried out in a plastic greenhouse with the configuration of 21 m, 9 m, and 3 m in length, width, and height, respectively, in 2018-19 at the Department of Horticulture Faculty of Agriculture University of Cukurova. The plants were grown under a bird net in the first year and the second year under UV plastic with a thickness of 0.4 mm. During the research, no heating process was conducted in the greenhouse.

In the first experimental year, the cuttings of the Early Cardinal variety were obtained from a commercial vineyard in Tarsus/Mersin on January 11, 2018. Cuttings were prepared from nodes 4-11 of canes (Anonymous 1995).

Cuttings were planted in perlite pools on January 15, 2018, and irrigated immediately after planting. Rooting of cutting occurred after approximately 90 days at a satisfactory level. Well-rooted cuttings were selected and transplanted into 32-liter plastic pots containing 4 different solid growing media, namely, zeolite, cocopeat, zeolite+cocopeat (Z+C) (1:1, v:v), and Z+C (1:2, v:v). A total of 3 different nutrient solutions were applied to the rooted cuttings: 2 chemical nutrient solutions (Hoagland and Hoagland A adapted to the vine) and organic liquid worm fertilizer (OLWF) (Table 1). The pots were placed in the greenhouse with a distance of 1.50 m between rows and 0.60 m in rows. After planting, a well-irrigation was performed to saturate the cultivation media. The pH value of the tap water used in the experiment was 7.68, and the EC value was 0.813 mS cm<sup>-1</sup>. The amount of water given to the plants varied between 1-3 L pot<sup>-1</sup> per day according to the water holding capacity of the growth medium. The total amount of nutrients applied per plant in the first year of the experiment is given in Table 2; those applied in different phenological periods in the second year are shown in Table 3.

In the first-year, to determine the effects of soilless culture media and nutrient solutions on plant growth and nutrition, shoot length and number of nodes were measured on three different dates (May 25, June 8, and June 22, 2018), shoot diameter during the dormancy period on December 28, 2018. To determine the effect of the applications, macro and micronutrient mineral analyzes were carried out using the leaf blades taken from the middle part of the shoot on June 26, 2018.

After the first year, the dormant vines were pruned on January 31, 2019. Pruning was conducted from the first node, leaving a single shoot over a one-

meter shoot length. The pruned vines were trained in a twisted guyot style to prepare for the crop year.

Grapevines were given different solutions within the scope of the second vegetation year, starting from the bud burst. On May 24, 2019, the excess clusters on the vines were removed and the number of clusters was equalized as 12 clusters.

Grape yield, cluster weight, berry weight and volume, Brix, acidity, pH, and maturity index properties were examined in the second year to determine the effect of the applications. The stem diameter of the plants was measured with a digital caliper at the height of 10 cm from the basal in three different phenological periods, namely, full bloom, maturity, and dormancy. In addition, the chlorophyll amount of the plants by a SPAD Meter (SPAD-502 Plus) device and the leaf temperature by an infrared thermometer (ScanTemp 485) was measured in the leaves at the middle part of the shoots at full bloom, leaf fall, and maturity at noon. In addition, macro and micronutrient mineral analyzes were carried out using leaf samples taken from opposite the clusters during full blooming and veraison.

Table 1. Composition and formula of chemical and organic nutrient solutions used in the trial

Element	Formula	HA	H	OLWF
		(mg kg <sup>-1</sup> )	(mg kg <sup>-1</sup> )	
N	K <sub>2</sub> (NO <sub>3</sub> ) <sub>2</sub>	150	210	%5
P	H <sub>3</sub> PO <sub>4</sub>	30	31	%0.49
K	K <sub>2</sub> SO <sub>4</sub>	175	235	%1.47
Mg	MgSO <sub>4</sub> .7H <sub>2</sub> O	20	48	%0.78
S	CaSO <sub>4</sub> .H <sub>2</sub> O	15	64	nd
Fe	Fe-EDDHA	5	2.5	5257 ppm
Mn	MnSO <sub>4</sub> .H <sub>2</sub> O	3	0.5	565 ppm
B	H <sub>3</sub> BO <sub>3</sub>	0.4	0.5	nd
Cu	CuSO <sub>4</sub> .5H <sub>2</sub> O	0.02	0.02	58 ppm
Zn	ZnSO <sub>4</sub> .7H <sub>2</sub> O	1	0.05	152.5 ppm
Mo	(NH <sub>4</sub> ) <sub>6</sub> Mo <sub>7</sub> O <sub>24</sub> .4H <sub>2</sub> O	0.05	0.01	nd
pH				5.28
Total Dry Matter				%13
Humic-Fulvic Acid				%38

HA:Hoagland A; H: Hoagland; OLWF: Organic Liquid Worm Fertilizer  
nd: non-determined



Table 2. The amount of nutrients applied per plant in the first year of the trial

Element	Hoagland A	Hoagland	Organic Liquid Worm Fertilizer
N (g)	12.75	17.85	37.40
P (g)	2.55	2.64	3.67
K (g)	14.87	19.97	10.99
Mg (g)	1.89	4.53	14.58
Zn (mg)	84.92	4.165	114.07
Cu (mg)	1.70	1.70	43.38
B (mg)	85.0	106.25	-
Mn (mg)	255.0	42.5	422.62
Mo (mg)	0.43	0.09	-
Fe (mg)	474.8	235.5	3932.2

Nitrogen (N) was determined according to Kjeldahl by using Shimadzu model UV 1201 spectrophotometer, phosphorus (P), vanado molibdo phosphoric yellow color method as reported by Bremner (1965). Potassium (K), calcium (Ca), magnesium (Mg), iron (Fe), zinc (Zn), copper (Cu), and manganese (Mn) contents of the leaves were determined by atomic absorption spectrophotometer (Kacar 1972).

The study was designed in 3 replications according to completely randomized plots in the first year and the randomized complete blocks experimental design in the second year. Each replicate contained three vines. Hence, the experiment was carried out with a total of 108 plants. The variance analysis of the obtained data was made using the JMP statistical program. The Least Significant Difference (LSD) test at a 5% significance level was used to separate different groups.

### 3. Results and Discussion

#### 3.1. Vegetative Development

The effect of different substrate and nutrient solution applications on shoot length, node number, and shoot diameter in the first year is given in Table 4. In three separate times (May 25, June 8, and June 22, 2018, respectively), values measured for shoot length (46.05, 105.6, and 191.0 cm, respectively) and the number of nodes (14.81, 24.63, and 33.19, respectively) in Z+C (1:1), shoot length values (46.67, 109.7, and 189.6 cm, respectively), and node numbers (15.96, 24.00 and

33.08, respectively) of vines grown in Z+C (1:2) medium were higher than other growing media. The effect of fertilization on the number of nodes was significant in all measurement times. Hoagland A and Hoagland nutrient solutions were statistically in the same group at the time of the first measurement of shoot length and the number of nodes and gave higher values than OLWF.

In shoot diameter measurement, Z+C (1:1 and 1:2) medium (11.48 and 11.32 mm, respectively) had higher values than cocopeat (9.04 mm) and zeolite (8.36 mm) media. Hoagland A and Hoagland nutrient solutions resulted in a larger diameter (9.33 mm) than the OLWF. Considering shoot length in the first two measurements, node counting in all three measurement times of the interaction was not significant (Table 4). Among the substrates used in the study, the cocopeat medium gave the lowest shoot length and node number values. Tangolar *et al.* (2017), in their study using cocopeat and peat+perlite (1:2) growing media, found that the effect of the substrate varies according to the varieties, and the highest shoot length and node number values in the cocopeat substrate in Yalova İncisi grape variety; They determined that the lowest shoot length and some nodes were obtained from Trakya Ilkeren and Prima varieties. Tangolar *et al.* (2019c), in another study in which they tried to determine the effect of three different substrates (cocopeat, perlite+peat (2:1) and basaltic pumice) on shoot length and the number of nodes of Early Sweet variety, including the cocopeat substrate, also found that the cocopeat substrate gave the lowest shoot length and the number of nodes. Baştaş & Tangolar (2018) determined the highest shoot length in plants in the cocopeat substrate using the same growth substrate. From these studies, it is seen that the effect of growing media varied according to genotypes.

The shoot diameter of the vine directly affected the crop load in the second year. Baştaş (2017), examining the effect of different soilless culture substrate on first-year in Prima and Early Sweet grape varieties, stated that the vines grown in cocopeat substrate gave higher values for shoot diameter, which is compatible with our study. Additionally, in our study, it is seen that Z+C mixtures for Early Cardinal give better results than pure cocopeat medium. The shoot diameter is, therefore, considered that the difference may be due to the positive effect of zeolite mixed with cocopeat on the vine development. Our results obtained in the first vegetation period before the crop year of the plant are important in providing preliminary information about the second-year grape yield. At the end of this experiment, the shoot diameter and length values obtained from all substrates and fertilizer applications at the end of the period were evaluated to be the first size according to the TS 4027 standard of cuttings and suitable for the characteristics of a well-lignified, reproductive annual cane (Anonymous 1995; Çelik *et al.* 1998).

Table 3. The amount of nutrients given per plant by different nutrient solutions in different phenological periods (second year)

Element	Hoagland A				Hoagland				Organic Liquid Worm Fertilizer			
	BB-BS	BS-V	V-M	Total	BB-BS	BS-V	V-M	Total	BB-BS	BS-V	V-M	Total
N (g)	9.60	6.00	5.40	21.00	13.44	8.40	7.56	29.39	26.40	17.60	15.90	59.90
P (g)	1.92	1.20	1.08	4.20	1.98	1.24	1.12	4.34	2.59	1.72	1.56	5.87
K (g)	11.20	7.00	6.30	24.50	15.04	9.40	8.46	32.89	7.76	5.17	4.67	17.61
Mg (g)	14.22	0.89	0.80	15.91	3.42	2.13	1.92	7.47	4.12	2.75	2.48	9.34
Zn (mg)	63.94	39.96	35.96	139.86	3.14	1.96	1.76	6.86	80.52	53.68	48.50	182.70
Cu (mg)	1.28	0.80	0.72	2.80	1.28	0.80	0.72	2.80	30.62	20.42	18.44	69.48
B (mg)	64.00	40.00	36.00	140.00	80.00	50.00	45.00	175.00	nd	nd	nd	nd
Mn (mg)	192.00	120.00	108.00	420.00	32.00	20.00	18.00	70.00	298.32	198.88	179.67	676.87
Mo (mg)	0.32	0.20	0.18	0.70	0.06	0.04	0.04	0.14	nd	nd	nd	nd
Fe (mg)	355.6	222.2	200.0	777.9	177.3	110.8	99.7	387.8	2775.7	1850.4	1671.7	6297.9

BB: Bud Break, BS: Berry Set, V: Veraison, M: Maturity, nd: non-determined

Table 4. The effect of different substrate and nutrient solution applications on shoot length, node number, and shoot diameter

Sources of Variation	May 25, 2018		June 8, 2018		June 22, 2018		December 28, 2018	
	Shoot length (cm)	Number of nodes (n)	Shoot length (cm)	Number of nodes (n)	Shoot length (cm)	Number of nodes (n)	Shoot length (cm)	Stem diameter (mm)
<b>Substrate</b>								
Zeolite	32.29 b <sup>y</sup>	13.82 bc	70.4 b	22.81	132.8 b	28.56 b	8.36 c	
Cocopeat	29.63 b	12.74 c	61.4 b	22.92	114.9 b	30.59 b	9.04 b	
Z+C (1:1) <sup>x</sup>	46.05 a	14.81 ab	105.6 a	24.63	191.0 a	33.19 a	11.48 a	
Z+C (1:2)	46.67 a	15.96 a	109.7 a	24.00	189.6 a	33.08 a	11.32 a	
LSD 5%	5.48	1.37	13.06	NS	18.49	2.11	0.55	
<i>p</i> value	<0.0001	0.0005	<0.0001	0.2301	<0.0001	0.0003	<0.0001	
<b>Fertilizer</b>								
Hoagland A	43.29 a	14.86 a	92.6 a	24.11 a	164.6 a	32.22 a	10.48 a	
Hoagland	39.58 a	14.89 a	88.8 ab	24.42 a	161.0 ab	32.39 a	10.34 a	
OLWF	33.11 b	13.25 b	78.8 b	22.25 b	145.5 b	29.44 b	9.33 b	
LSD 5%	4.75	1.18	11.3	1.78	16.01	1.83	0.48	
<i>p</i> value	0.0007	0.0123	0.0509	0.0406	0.0494	0.0043	<0.0001	
<b>Interaction</b>								
LSD 5%	NS	NS	NS	NS	32.03	NS	0.96	
<i>p</i> value	0.901	0.2717	0.2117	0.7341	0.0594	0.1866	0.0226	

<sup>x</sup>Z+C: Zeolite+Cocopeat, OLWF: organic liquid worm fertilizer, NS: Non-Significant, <sup>y</sup>Mean separation within columns by LSD multiple range test at 0.05 level

### 3.2. Chlorophyll Amount, Leaf Temperature, and Stem Diameter

The effect of different substrate applications on the amount of chlorophyll was significant during full blooming and veraison, although no significant difference was found during the maturity stage. While the highest chlorophyll amount was detected in Z+C (1:2) substrate (36.88) at the full blooming stage, Z+C (1:1), Z+C (1:2), and cocopeat substrate were in the same statistical group, and the highest chlorophyll values (37.25, 37.73 and 37.04, respectively). The difference in the effect of different nutrient solution applications on leaf chlorophyll amounts at full bloom times was not significant. The highest amount of chlorophyll was measured in grapevines where Hoagland A and Hoagland fertilizers were applied during the veraison and maturity stages (Table 5). It has been observed in various studies that leaf chlorophyll contents vary based on the species, varieties, and applications (Sarı 2019). These measurements, Kaya *et al.* (2018), were found to be lower than the SPAD values (42.5 and 40.6, respectively), they obtained in Prima and Yalova incisi grape varieties grown in the Cocopeat substrate.

Regarding the leaf temperatures measured in full bloom, veraison, and maturity with the infrared thermometer device, the highest values were detected in zeolite substrate (43.95, 45.11, and 46.34 °C, respectively) in all three stages. In point of nutrient solutions, the highest leaf temperature values were measured in grapevines applied with OLWF (39.14, 44.61, and 46.24 °C, respectively) in these phenological stages. While there were significant differences in substrate and fertilizer applications in full bloom and veraison stages, leaf temperatures were not determined significant differences during the maturity stage (Table 5). Additionally, it was observed that leaf temperatures increased by 2-9 °C in each measurement when compared to the previous measurement. This could possibly be due to the increase in ambient temperatures. Leaf temperature was measured as 45.11 °C maximum and 38.07 °C minimum during the veraison stages. These values were higher than the highest leaf temperature values measured as 34.13 °C and the lowest 32.10 °C by infrared thermometer during the veraison stage in the Trakya Ilkeren variety cultivated in the open vineyard by Doğan (2020). This could possibly be because high humidity under cover affects the plant more than growing in open conditions.

In the second year of the study, according to stem diameters in respectively of full bloom, veraison, and maturity Z+C (1:1) (13.62 mm, 15.17 mm and 14.60 mm, in measurement time, respectively) and Z+C (1:2) (12.84, 14.67 and 14.49 mm, in measurement time, respectively) gave higher values than zeolite and cocopeat applications.

The stem diameters of the vines fertilized with Hoagland A and Hoagland fertilizers were thicker than the vines subjected to organic fertilizers in all three phenological stages as in the first year (Table 5). These values in the study of Baştaş (2017) were the lowest as 16.17 mm (basaltic pumice) and the highest stem diameter measurements in the period of veraison and maturity in the Prima grape variety grown in three different substrates (cocopeat, perlite+peat (2:1), basaltic pumice) as 18.07 mm (perlite+peat). In the Early Sweet variety, it was determined that the value is in close similarity with the values of the lowest 14.32 mm (perlite+peat) and the highest 16.86 mm (cocopeat) in the veraison and maturity period.

Likewise, Kaya (2018) stated that the highest value was obtained from cocopeat substrate (20.01 mm) in the Prima variety and perlite+peat (21.87 mm) in the stem diameter measurements made at maturity in the two-year-old Yalova incisi and Prima. Considering the stem diameter values for two-year-old grapevines and the measured stem diameter for one-year-old grapevine in the study, those values like the results of Z+C (1:1 and 1:2) substrate were evaluated, which gave the best rates in our study.

As a result of the measurements we obtained in both the full bloom and maturity stage, it was concluded that the plant stem diameter was thickened after adding zeolite to the cocopeat material. As a result, the yield ultimately increased. However, the values determined in OLWF are within the 8-12 mm values given for the 1st size vine cutting in TS 4027 cutting standard (Anonymous 1995; Çelik *et al.* 1998).

Table 5. The effect of different substrate and nutrient solution applications on chlorophyll amount, leaf temperature, and shoot diameter measured in different phenological periods

Sources of Variation	Chlorophyll Index			Leaf Temperatures (°C)			Stem Diameter (mm)		
	Full Blooming	Veraison	Maturity	Full Blooming	Veraison	Maturity	Full Blooming	Veraison	Maturity
<b>Substrate</b>									
Zeolite	34.58 b <sup>y</sup>	36.02 b	34.07	43.95 a	45.11 a	46.34	10.19 c	11.40 c	11.58 c
Cocopeat	34.87 b	37.04 a	36.92	33.80 c	38.07 c	45.43	10.08 c	12.99 b	13.19 b
Z+C (1:1) <sup>x</sup>	35.92 ab	37.25 a	36.41	36.32 b	43.90 a	45.95	13.62 a	15.17 a	14.60 a
Z+C (1:2)	36.88 a	37.73 a	37.31	31.77 d	40.57 b	45.33	12.84 b	14.67 a	14.49 a
LSD 5%	1.50	0.95	NS	1.54	1.64	NS	0.73	0.73	0.75
<i>p value</i>	0.0176	0.0090	0.1580	<0.0001	<0.0001	0.4568	<0.0001	<0.0001	<0.0001
<b>Fertilizer</b>									
Hoagland A	35.50	38.64 a	38.12 a	35.37 b	40.68 b	45.27	12.21 a	14.56 a	14.62 a
Hoagland	35.51	37.85 a	37.66 a	34.87 b	40.45 b	45.78	11.92 a	13.91 b	14.07 a
OLWF	35.68	34.55 b	32.75 b	39.14 a	44.61 a	46.24	10.92 b	12.35 c	11.58 b
LSD 5%	NS	0.82	3.28	1.33	1.42	NS	0.64	0.63	0.65
<i>p value</i>	0.9489	<0.0001	<0.0001	<0.0001	<0.0001	0.2989	0.0009	<0.0001	<0.0001
<b>Interaction</b>									
LSD 5%	2.61	NS	NS	NS	NS	2.52	NS	NS	NS
<i>p value</i>	0.0503	0.5176	0.2848	0.7621	0.6917	0.0197	0.0604	0.1602	0.1557

<sup>x</sup>Z+C: Zeolite+Cocopeat, OLWF: organic liquid worm fertilizer, NS: Non-Significant, <sup>y</sup>Mean separation within columns by LSD multiple range test at 0.05 level



### 3.3. Yield, Cluster, Berry Weight and Volume

The main philosophy of the soilless agricultural unit area in the world and Türkiye is considered as achieving higher efficiency and quality of the product. This study aims to place more plants per unit area and get much more yield per hectare. Therefore, the density of pots has been maximized. The rows of the grapevines are 0.6 meters on the row and 1.5 meters between the rows, and one plant is placed in an area of 0.9 m<sup>2</sup>. In the study, 1111 grapevines per decare were found.

The effects of different substrate and nutrient solution applications on yield, cluster weight, berry weight, and volume are given in Table 6. The highest yield (3456 g vine<sup>-1</sup> and 3492 g vine<sup>-1</sup>, respectively) and cluster weight (288.0 g and 291.0 g, respectively) have been taken from 1:1 and 1:2 mixed media of Z+C, where there is no significant difference between them. When the values of hundred berry weight and volume were examined, the best results were obtained from Z+C (1:2) mixture medium (440.5 g and 421.1 mL, respectively).

Differences in yield were found important between different substrates. It has been determined that Z+C (1:1) and Z+C (1:2) mixed media give twice the efficiency than zeolite and cocopeat substrate alone. These values are respectively 38.4 ton ha<sup>-1</sup> and 38.9 ton ha<sup>-1</sup> in the mixed substrate, 17.2 ton ha<sup>-1</sup> in cocopeat, 16.9 ton ha<sup>-1</sup> in zeolite. The yield of grapes per hectare in the open in Türkiye is reported to be 1027 kg (Söylemezoğlu *et al.* 2020). TUIK (2021) reported the amount of grape production in Türkiye is 10 tons per hectare. Zeolite substrate according to these results 1.9 times, cocopeat substrate 2 levels, Z+C (1:1) substrate 4.4 times, and Z+C (1:2) substrate gave 4.5 times more grape yield by the Türkiye average. In this way, the highest yield (3078 g vine<sup>-1</sup> /34.2 ton ha<sup>-1</sup>) was obtained from vines fertilized with Hoagland nutrient solution, while Hoagland A with a yield of 2718 g vine<sup>-1</sup> (30.2 ton ha<sup>-1</sup>) and OLWF was in third place with 1715 g vine<sup>-1</sup> (19.1 ton ha<sup>-1</sup>). Compared to Türkiye average of the data obtained from different fertilizing Hoagland A to 3.5 times higher than the Hoagland fertilizer 3.9-fold and vines the 100% OLWF by cultivation in normal soil 2.2 times more grapes were taken.

The highest cluster weight was obtained from plants given Hoagland A (260.3 g) and Hoagland solution (280.7 g), whereas the lowest value obtained from OLWF (157.5g). The highest values in terms of hundred berry weight and volume were obtained from Hoagland A (432.4 g and 407.1 mL, respectively) and Hoagland (412.6 g and 387.9 mL, respectively) solutions, and they were statistically in the same group. The lowest values (253.5 g and 245.0 mL, respectively) were obtained from vines fertilized with OLWF (Table 6).

The bunches obtained from Z+C (1:1) and Z+C (1:2) media and Hoagland and Hoagland A fertilized vines are classified as “medium-sized bunches”. In contrast, zeolite, cocopeat, and clusters obtained from OLWF were found to be in the “medium-small bunches” class (Çelik 2011). According to TSE 101 (Anonymous 2012), clusters obtained from Z+C (1:1) and Z+C (1:2) media and Hoagland and Hoagland A nutrient solutions are in the “Extra” group, cocopeat substrate “first-class bunch” with zeolite substrate organic worm manure is in the “second class bunch” class. According to the parameters of 100 berry volume and 100 berry weight, the berries obtained from zeolite substrate and OLWF were classified as “medium-sized berries,” and the berries obtained from other media and fertilizer solutions were found to be classified as “large berries” (Çelik, 2011).

### 3.4. Must Properties

The highest TSS and acidity values were obtained from the cocopeat substrate (14.81% and 0.463 g 100 mL<sup>-1</sup>, respectively). It has been determined that different substrates have no statistically significant effect on pH and maturity index (Table 7).

Table 6. The effect of different substrate and nutrient solution applications on yield, cluster weight, berry weight and volume

Sources of Variation	Yield (g vine <sup>-1</sup> )	Cluster weight (g)	Berry weight (g 100 berries <sup>-1</sup> )	Berry volume (mL 100 berries <sup>-1</sup> )
<b>Substrate</b>				
Zeolite	1519 b <sup>y</sup>	126.6 c	269.9 c	253.3 c
Cocopeat	1547 b	225.7 b	389.9 b	358.9 b
Z+C (1:1) <sup>x</sup>	3456 a	288.0 a	364.4 b	353.3 b
Z+C (1:2)	3492 a	291.0 a	440.5 a	421.1 a
LSD 5%	380.8	37.3	32.2	35.3
<i>p</i> -value	<0.0001	<0.0001	<0.0001	<0.0001
<b>Fertilizer</b>				
Hoagland A	2718 b	260.3 a	432.4 a	407.1 a
Hoagland	3078 a	280.7 a	412.6 a	387.9 a
OLWF	1715 c	157.5 b	253.5 b	245.0 b
LSD 5%	329.8	32.3	27.9	30.6
<i>p</i> -value	<0.0001	<0.0001	<0.0001	<0.0001
<b>Interaction</b>				
LSD 5%	NS	NS	NS	NS
<i>p</i> -value	0.1910	0.1583	0.1398	0.1170

<sup>x</sup>Z+C: Zeolite+Cocopeat, NS: Non-Significant, OLWF: organic liquid worm fertilizer;

<sup>y</sup>Mean separation within columns by LSD multiple range test at 0.05 level

While the effect of different nutrient solutions on Brix was not significant, the highest acidity value was found in vines with OLWF. In terms of maturity index and pH values, Hoagland A (33.91 and 3.90, respectively) and Hoagland (34.97 and 3.94, respectively) were in the same group, followed by OLWF (28.33 and 3.59, respectively). It was determined that the interaction was significant in the TSS, acidity, and maturity index but not in pH (Table 7). The must data showed that all vines are grown with different substrates. Different nutrient solutions meet the desired Brix value in the range of 12-20% and the maturity index value of 20 and above in early table grape varieties (Uzun 2004; Çelik 2011). In this study, the Brix value we obtained from the cocopeat substrate, Kaya *et al.* (2018) have a higher Brix value (13.69% and 12.90%, respectively) in the Yalova incisi variety grown in cocopeat substrate and Baştaş & Tangolar (2018) in the Prima grape variety grown in cocopeat substrate (14.81%). Brix values were found lower than the values obtained from Cardinal variety (15.9%) grown in peat+perlite medium of Buttarò *et al.* (2012).

### 3.5. Plant Nutrition Findings

According to the analysis results of the leaf blade samples taken from plants in 2018, it was determined that the highest N concentration was in zeolite and Z+C (1:1) and (1:2) (3.22%, 3.06%, and 3.27%, respectively). Cocopeat, in terms of P (1.11%) and K (2.17%); zeolite for Ca (1.45%), zeolite and Z+C mixtures for N and Z+C (1:2) mixture for Mg (0.44%) concentration of the leaves gave the higher values than the others. The effect of the substrates on the Zn concentration was not significant. Fe value of leaves (184.4 mg kg<sup>-1</sup>) in cocopeat; Mn values (226.3 mg kg<sup>-1</sup>) were higher in Z+C (1:2) substrate. It was determined that while the effects of fertilizer applications on P, K, Ca, and Mg were significant, whereas the effect on the nitrogen concentration in leaf blade samples was not significant. The highest P and Mg concentrations were found in leaves of vines treated with Hoagland (0.97% and 0.45%, respectively) nutrient solution. In terms of K, the highest value was in the grapevines, where OLWF was applied with nutrient solution. The highest Ca concentration was obtained from Hoagland A and OLWF. Zn (26.33 mg kg<sup>-1</sup>) and Mn (381.3 mg kg<sup>-1</sup>) concentrations in leaves taken from vines with OLWF were higher than Hoagland and Hoagland A solutions. Fe (182.9 mg kg<sup>-1</sup>) value in vine leave fed with Hoagland A fertilizer was higher than those fed with OLWF. It has been determined that the interaction was significant in elements, except for Zn (Table 8).

Table 7. Effects of different substrate and nutrient solution applications on must properties

Sources of Variation	TSS (%)	Acidity (g 100 mL <sup>-1</sup> )	pH	Maturity index
<b>Substrate</b>				
Zeolite	13.64 b <sup>y</sup>	0.408 b	3.78	33.63
Cocopeat	14.81 a	0.463 a	3.84	32.45
Z+C (1:1) <sup>x</sup>	12.62 c	0.409 b	3.85	32.47
Z+C (1:2)	13.01 bc	0.438 ab	3.77	31.05
LSD 5%	0.71	0.044	NS	NS
<i>p value</i>	<0.0001	0.0484	0.1061	0.5682
<b>Fertilizer</b>				
Hoagland A	13.57	0.406 b	3.90 a	33.91 a
Hoagland	13.46	0.390 b	3.94 a	34.97 a
OLWF	13.54	0.492 a	3.59 b	28.33 b
LSD 5%	NS	0.038	0.07	3.23
<i>p value</i>	0.9321	<0.0001	<0.0001	0.0006
<b>Interaction</b>				
LSD 5%	1.24	0.076	NS	6.47
<i>p value</i>	0.0005	0.0004	0.3619	0.0007

<sup>x</sup> Z+C: Zeolite+Cocopeat, NS: Non-Significant, OLWF: organic liquid worm fertilizer;

<sup>y</sup> Mean separation within columns by LSD multiple range test at 0.05 level

In the second year of the study (2019), the leaf samples were taken from the vines of different media and fertilizer applications were analyzed during the full bloom stage, showing that the applications' effects on the macro and micronutrient concentrations were significant. Higher N, P, K, and Mg concentrations (3.61%, 0.99%, 1.88%, and 0.76%, respectively) were obtained from cocopeat substrate. The highest iron values in zeolite, zinc, and manganese were higher in zeolite and Z+C mixtures. The effect of different fertilizer solution applications on the N, K, Zn, and Fe concentrations of the leaves taken during the full flowering stage did not display a statistical difference. The highest P level was detected in vine leaves fertilized with Hoagland (0.84%), and the highest Mg nutrient concentration (0.78%) was determined in vine leaves fertilized with OLWF. Among the nutrient solution applications, Ca concentration was high in Hoagland A and OLWF fertilized vine leaves (1.54% and 1.50%, respectively).

The highest Mn concentration was determined in vine leaves treated with OLWF. The effect of the interaction on the concentrations of macro and micronutrients in the leaves taken during full bloom was insignificant (Table 9). In the second year of the study (2019), it was determined that the effect of different substrate and different nutrient solution applications on macro and micronutrient concentrations in leaf samples taken during the veraison stage was significant.

To sum up, it has been determined that the effect of cultivation media on the concentration of N, P, K, and Ca nutrients was significant. However, the other nutrients did not show significant variances. The highest N concentration was detected in zeolite substrate and Z+C (1:1) (2.75% and 2.59%, respectively); P and K concentrations were obtained from vines grown in cocopeat (1.22% and 1.04%, respectively) medium. The highest Ca concentration was determined in vines grown in a zeolite substrate (2.35%). It has been determined that the effect of different fertilizer solution applications on P, Zn, and Mn concentrations was significant, but its effect on other nutrients was not significant. The highest concentrations in vines, from Hoagland for P, from OLWF for Zn and Mn were obtained. It has been determined that the effect of interaction on macro and micronutrient concentrations of leaves taken during the veraison stage was insignificant (Table 10).

Gül *et al.* (2006) reported that adding zeolite to the soilless culture medium significantly increases the amount of K absorbed by the plants and decreases the amount of K drained from the substrate. This is due to the ability of zeolite to hold K ions. In our study, it was seen that the opposite result came out in the first year. A lower concentration of K was detected in leaf samples taken from each of the three substrates where the zeolite was found than in the cocopeat substrate. This outcome may have been resulted from the interaction of the fertilizers used in the study with zeolite. According to the limit values reported by Jones *et al.* (1991), the results of leaf analysis obtained from grapevines fertilized with different nutrient solutions, high concentration of N, P, and Fe in vines fed with Hoagland A; Mg and Mn concentration is sufficient; it showed that the concentration of K, Ca and Zn was deficient. According to the limit values reported by the same researchers, N and P concentrations were high in vines fertilized with Hoagland; Mg, Fe, and Mn are sufficient; K, Ca, and Zn was determined to be deficient. Concentrations of N, P, and Mn are high in vines applied with OLWF; Mg, Zn, and Fe are sufficient; K and Ca concentrations were deficient.

According to the limit values of the leaf blade nutrient element explained by Robinson (1990) for the full blooming stage, in terms of nutrient concentrations in all substrate and fertilizer applications, N was sufficient, Mg excess and Zn were within low limit values. Besides, K concentration was high in cocopeat, sufficient in other substrate and nutrient solution applications, P concentration is sufficient in zeolite substrate, it is higher in other applications. According to the leaf nutrient limit values explained by the same researcher for the veraison, it was determined that the N concentration was sufficient, Mg was high, and Zn was low in all substrate and fertilizer applications.

Regarding the nutrient limit values explained by Jones et al. (1991) for the full blooming stage, it was determined that N is in excess, Mg and Fe are sufficient, and Zn is in the deficiency group in all substrates and fertilizer applications. Besides, the P nutrient element is sufficient in zeolite, Z+C (1:1), and OLWF, it is sufficient in other applications. K element is sufficient in cocopeat and Hoagland applications; it is deficient in other applications. Ca concentration is deficient in cocopeat substrate; in other applications, it is sufficient. Mn concentration is sufficient in cocopeat substrate. It was found to be more in other substrate and nutrient solutions. From the veraison stage nutrient limit values, obtained from all medium and fertilizer applications; K and Zn concentration was incomplete, Mn to be sufficient and Mg concentration to be excessive (Jones et al. 1991).

When the nutrient limit values determined by Benito et al. (2015) for the full bloom stage and the values obtained in our study are compared, P, K, and Mg concentrations are high in all substrate and fertilizer applications; Ca, Zn, and Fe concentrations were found to be below. One of the microelements, Mn is sufficient in the cocopeat substrate; it was found to be high in other applications. Grapevines given Hoagland A nutrient solution with zeolite and Z+C (1:1) medium of nitrogen concentration are sufficient; in other applications, it has been determined to be in high limit values. Considering the nutrient limit values determined by Benito et al. (2015) for leaf blades in the veraison stage, P and Mg concentrations are high in all media and fertilizer applications; Ca and Fe concentrations are in a low class.

Table 8. The effect of different substrates and nutrient solution applications on macro and micronutrient concentrations in first-year leaf samples (2018 year)

Sources of Variation	Macroelements (%)				Microelements (mg kg <sup>-1</sup> )			
	N	P	K	Ca	Mg	Zn	Fe	Mn
<b>Substrate</b>								
Zeolite	3.22 a <sup>y</sup>	0.37 d	0.80 b	1.45 a	0.41 b	20.16	172.4 b	182.4 b
Cocopeat	2.55 b	1.11 a	2.17 a	0.22 d	0.36 c	17.65	184.4 a	199.4 ab
Z+C (1:1) <sup>x</sup>	3.06 a	0.64 c	0.83 b	1.18 b	0.39 b	16.40	156.2 c	177.5 b
Z+C (1:2)	3.27 a	0.80 b	0.84 b	1.05 c	0.44 a	22.90	157.6 c	226.3 a
LSD 5%	0.24	0.07	0.10	0.09	0.03	NS	7.82	32.08
<i>p</i> value	<0.0001	<0.0001	<0.0001	<0.0001	<0.0001	0.5572	<0.0001	0.0195
<b>Fertilizer</b>								
Hoagland A	3.07	0.73 b	1.15 b	0.98 a	0.42 b	16.36 b	182.9 a	83.3 c
Hoagland	3.03	0.97 a	1.06 c	0.90 b	0.45 a	15.16 b	163.0 b	124.5 b
OLWF	2.99	0.49 c	1.27 a	1.05 a	0.34 c	26.33 a	157.1 b	381.3 a
LSD 5%	NS	0.06	0.09	0.08	0.02	8.69	6.77	27.78
<i>p</i> value	0.6924	<0.0001	0.0003	0.0013	<0.0001	0.0268	<0.0001	<0.0001
<b>Interaction</b>								
LSD 5%	0.41	0.12	0.17	0.15	0.05	NS	13.54	55.57
<i>p</i> value	<0.0001	<0.0001	<0.0001	0.0115	<0.0001	0.4510	0.0006	<0.0001

<sup>x</sup> Z+C: Zeolite+Cocopeat, OLWF: organic liquid worm fertilizer, NS: Non-Significant,

<sup>y</sup> Mean separation within columns by LSD multiple range test at 0.05 level



Table 9. The effect of different substrate and nutrient solution applications on macro and micronutrient concentrations in leaf samples at full bloom (2019 year)

Sources of Variation	Macroelements (%)					Microelements (mg kg <sup>-1</sup> )				
	N	P	K	Ca	Mg	Zn	Fe	Mn		
<b>Substrate</b>										
Zeolite	3.09 b <sup>y</sup>	0.33 b	1.15 b	1.72 a	0.62 b	12.18 a	85.0 a	222.9 a		
Cocopeat	3.61 a	0.99 a	1.88 a	0.86 b	0.76 a	9.41 b	61.3 b	140.0 b		
Z+C (1:1) <sup>x</sup>	3.14 ab	0.46 b	1.20 b	1.66 a	0.78 a	12.05 a	65.4 b	223.1 a		
Z+C (1:2)	3.56 ab	0.64 b	1.45 b	1.39 a	0.74 a	11.89 a	57.2 b	183.0 ab		
LSD 5%	0.48	0.33	0.39	0.37	0.10	2.11	9.62	67.7		
<i>p-value</i>	0.0675	0.0029	0.0026	0.0003	0.0154	0.0364	<0.0001	0.0553		
<b>Fertilizer</b>										
Hoagland A	3.19	0.55 b	1.31	1.54 a	0.68 b	11.16	67.6	153.7 b		
Hoagland	3.43	0.84 a	1.50	1.18 b	0.71 ab	10.59	64.4	152.7 b		
OLWF	3.43	0.42 b	1.45	1.50 a	0.78 a	12.39	69.6	270.3 a		
LSD 5%	NS	0.29	NS	0.32	0.19	NS	NS	58.6		
<i>p-value</i>	0.3943	0.0191	0.4855	0.0559	0.0842	0.1358	0.4476	0.0004		
<b>Interaction</b>										
LSD 5%	NS	NS	NS	NS	NS	NS	NS	NS		
<i>p-value</i>	0.5162	0.9912	0.1702	0.7908	0.2068	0.0970	0.6612	0.1984		

<sup>x</sup> Z+C: Zeolite+Cocopeat, OLWF: organic liquid worm fertilizer, NS: Non-Significant,

<sup>y</sup> Mean separation within columns by LSD multiple range test at 0.05 level

Table 10. The effect of different substrate and nutrient solution applications on macro and micronutrient concentrations in leaf samples at verasion (2019 year)

Sources of Variation	Macroelements (%)				Microelements (mg kg <sup>-1</sup> )			
	N	P	K	Ca	Mg	Zn	Fe	Mn
<b>Substrate</b>								
Zeolite	2.75 a <sup>y</sup>	0.26 b	0.60 b	2.35 a	0.89	8.84	58.5	213.7
Cocopeat	2.33 b	1.22 a	1.04 a	0.93 c	0.87	11.53	54.9	151.1
Z+C (1:1) <sup>x</sup>	2.59 a	0.32 b	0.45 b	2.26 ab	0.96	11.00	61.0	221.4
Z+C (1:2)	2.20 b	0.64 b	0.55 b	1.82 b	1.00	11.54	56.7	192.0
LSD 5%	0.18	0.41	0.27	0.51	NS	NS	NS	NS
<i>p-value</i>	<0.0001	0.0002	0.0007	<0.0001	0.2149	0.2891	0.5353	0.4222
<b>Fertilizer</b>								
Hoagland A	2.52	0.59 ab	0.69	1.90	0.90	10.24 ab	57.4	187.4 ab
Hoagland	2.39	0.80 a	0.67	1.70	0.94	9.24 b	54.1	146.8 b
OLWF	2.50	0.44 b	0.62	1.91	0.95	12.70 a	61.7	249.5 a
LSD 5%	NS	0.35	NS	NS	NS	2.82	NS	81.0
<i>p-value</i>	0.2155	0.1316	0.7788	0.5553	0.6486	0.0500	0.1496	0.0478
<b>Interaction</b>								
LSD 5%	NS	NS	NS	NS	NS	NS	NS	NS
<i>p-value</i>	0.2660	0.8876	0.7474	0.6066	0.4635	0.9840	0.5266	0.9950

<sup>x</sup> Z+C: Zeolite+Cocopeat, OLWF: organic liquid worm fertilizer, NS: Non-Significant,

<sup>y</sup> Mean separation within columns by LSD multiple range test at 0.05 level

## Conclusion

As a result of the study, in the first year, the effect of Z+C mixing media and HA and H chemical fertilizers on shoot growth was better than the other applications. In the second year, while satisfactory yields were obtained from all substrates and vines have given OLWF with both chemicals, and appropriate quality was achieved, both Z+C (1:1 and 1:2) mixtures could be successfully used in soilless culture grape cultivation. As a growth medium, it was concluded that using zeolite alone would not be suitable enough, and using cocopeat mixed with zeolite would be more effective. In the fertilizer experiments, the values obtained from the grapevines given Hoagland and Hoagland A solution were very close. Both applications gave higher values than the OLWF application. Macro and micronutrients determined in our experiment for all substrates and fertilizer applications were generally evaluated as sufficient or excess, according to the nutrient limit values given by some researchers for the full blooming and veraison stage. It has also been concluded that it can be recommended to use different doses in OLWF to increase the yield even more.

## Acknowledgments

This article was generated from the Master Thesis of Mikail Atalan, whose study was supported by the Cukurova University Scientific Research Coordination Unit (Project No: FYL-2018-11066). The authors would also like to thank Dr. Ali Sabır for language editing and his valuable comments.

## References

- Aksoy U (2001). Ekolojik tarım: Genel bir bakış. Türkiye 2. Ekolojik Tarım Sempozyumu, 14-16 Kasım, Antalya.
- Anonymous (1995). Asma çeliği standardı TS 4027. Türk Standartları Enstitüsü. Necatibey Caddesi. 112. Bakanlıklar/Ankara.
- Anonymous (2012). Sofralık üzüm standardı TS 101. Türk Standartları Enstitüsü, Necatibey Caddesi. 112. Bakanlıklar/Ankara.
- Baştaş P C & Tangolar S (2018). The Effect of growing medium and crop loads on yield and some quality properties of Prima grape cultivar grown in soilless culture. *Alatarım* 17 (2): 98-109. [in Turkish].
- Baştaş P C (2017). The Effect of growing medium and crop loads on yield and some quality properties of table grape cultivars grown in soilless culture. MSc Thesis. Cukurova University, Institute of Natural And Applied Sciences, Department of Horticulture. 149 p. [in Turkish].

- Benito A; García-Escudero E; Romero I; Domínguez N & Martín I (2015). Sufficiency ranges (sr) and deviation from optimum percentage (dop) references for leaf blade and petiole analysis in 'Red Grenache' rapevines. *OENO One* 49(1): 47-58.
- Bozköylü A & Daşgan H Y (2010). Comparison of organic and chemical nutrition in soilless grown tomato. *Tübvav Bilim Dergisi* 3(2): 174-181. [in Turkish].
- Bremner J M (1965). Total nitrogen. In: *Methods of soil analysis - Part 2.* (Ed: C.A. Black), Madison (WI): American Society of Agronomy Inc. 1149–1178.
- Buttaro D; Serio F & Santamaria P (2012). Soilless greenhouse production of table grape under Mediterranean conditions. *Journal of Food Agriculture & Environment* 10 (2): 641-645
- Çelik S (2011). Bağcılık (Ampeloloji) Cilt 1. Trakya Üniversitesi Tekirdağ Ziraat Fakültesi Bahçe Bitkileri Bölümü. *Anadolu Matbaa Ambalaj San ve Tic. Ltd.Şti.* 426 s.
- Çelik H; Ağaoğlu Y S; Fidan Y; Marasalı B & Söylemezoğlu G (1998). Genel Bağcılık. Sunfidan A.Ş. Mesleki Kitaplar Serisi:1, Ankara, 245s.
- Di Lorenzo R; Pisciotta A; Santamaria P & Scariot V (2013). From Soil to Soil-Less in Horticulture: Quality and Typicity *Italian Journal of Agronomy* 8-E30: 255:260p.
- Doğan G (2020). The Effect of irrigation and mulching applications on yield, quality, and ecophysiological characteristics of Trakya İlkeren grape variety. MSc Thesis. Cukurova University, Institute of Natural And Applied Sciences, Department of Horticulture. 76 p. [in Turkish].
- Gül A; Eroğul D; Ongun A R & Tepecik M (2006). Zeolite acts potassium nutrition. *Tarımda Potasyumun Yeri ve Önemi Çalıştayı*, 3-4. [in Turkish].
- Jones J B; Wolf Jr B & Mills H A (1991). *Plant Analysis Handbook.* Micro Macro Publishing, Inc., USA. p 1-213.
- Kacar B (1972). Bitki ve toprağın kimyasal analizleri, II. Bitki Analizleri, Ankara Üniv. Zir. Fak. Yayınları, 453s.
- Kaya S (2018). The Effect of root pruning applications on yield and quality of some table grape varieties of different ages grown in different solid culture media. MSc Thesis. Cukurova University, Institute of Natural And Applied Sciences, Department of Horticulture. 91 p. [in Turkish].
- Kaya S; Tangolar S & Tangolar S (2018). The effect of root pruning applications on yield and quality of some table grape varieties grown in different solid culture media. *Bahçe* 47 (Özel Sayı 1: Türkiye 9. Bağcılık ve Teknolojileri Sempozyumu): 575-585. [in Turkish].


- Koral P S (2006). The comparison of grape marc and coal cinder the cheapest substrates that can be used in soilless culture with perlite and greenhouse soil, regarding their influence of growth, yield, and crop. Ph.D. Thesis. Trakya University, Institute of Natural And Applied Sciences, Department of Horticulture. 209 p. [in Turkish].
- Robinson J B (1990). Grape nutrition on update. The Australian. Grapegrower and Winemaker. November 9-12.
- Sarı G (2019). Effects of zinc applications on growth and physiology of 'Alphonse Lavallée' and 'Italia' table grapes under deficit irrigation condition. MSc Thesis. The Graduate School of Natural and Applied Science of Selçuk University. 51 p. [in Turkish].
- Sevgican A; Tüzel Y; Gül A & Eltez R Z (2000). Türkiye'de örtüaltı yetiştiriciliği. V. Türkiye Ziraat Teknik Kongresi 17-21 Ocak, 2. Cilt, TMMOB Ziraat Mühendisleri Odası 679-707, Ankara.
- Söylemezoğlu G; Çelik H; Kunter B; Ünal A; Özer C; Kiracı M A; Akkurt M; Boz Y & Tahmaz Karaman H (2020). Bağcılıkta mevcut durum ve gelecek. Türkiye Ziraat Mühendisliği IX. Teknik Kongresi, 13-17 Ocak, Ankara, 609-645.
- Tangolar S (2016). Örtüaltında Bağcılık. Bahçe Haber 5(1):14-19.
- Tangolar S; Tangolar S; Alkan Torun A; Tarım G & Ada M (2017). Evaluation of table grape cultivation in soilless culture system. Türkiye Tarımsal Araştırmalar Dergisi 4(2): 163-170.
- Tangolar S; Tangolar S; Alkan Torun A; Tarım G; Ada M & Aydın O (2019a). Effects of different nutrient solutions and growing media on yield and quality in grape growing in soilless culture. 8. Ulusal Bitki Besleme ve Gübreleme Kongresi 12-15 Mart 2019 Antalya. Mediterranean Agricultural Sciences 32(Özel Sayı): 127-133.
- Tangolar S; Tangolar S; Tarım G; Ada M; Alkan Torun A & Ertargın E (2019b). The effects of different nitrogen and potassium levels on yield and quality of two early grape cultivars grown in different soilless media. Acta Hort. 1242, 349-356. <https://doi.org/10.17660/ActaHortic.2019.1242.49>.
- Tangolar S; Baştaş P C; Alkan Torun A. & Tangolar S (2019c). Effects of substrate and crop load on yield and mineral nutrition of 'Early Sweet' grape cultivar grown in soilless culture. Erwerbs-Obstbau 61(Suppl 1): S33-S40.
- TUIK (2021). Data portal for statistics. <https://data.tuik.gov.tr/Kategori/GetKategori?p=Tarim-111> (Accessed on September 27, 2021).
- Uzun I (2004). Bağcılık. Hasad Yayıncılık Ltd. Şti. 156 s. [in Turkish].





# CHAPTER 10


## CULTIVATION OF TABLE GRAPES IN SOILLESS CULTURE SYSTEM

Serpil TANGOLAR<sup>1✉</sup> & Semih TANGOLAR<sup>2</sup> & Sevil CANTURK<sup>3</sup>  
Melike ADA<sup>4</sup>

<sup>1</sup>(Prof. Dr.), Çukurova University, Faculty of Agriculture, Department of Horticulture, Adana, Türkiye, e-mail: stangolar@cu.edu.tr  
 <https://orcid.org/0000-0002-5563-1972>

<sup>2</sup>(Prof. Dr.), Çukurova University, Faculty of Agriculture, Department of Horticulture, Adana, Türkiye, e-mail: tangolar@cu.edu.tr  
 <https://orcid.org/0000-0001-7746-4258>

<sup>3</sup>(Asst. Prof.), Çukurova University, Faculty of Agriculture, Department of Horticulture, Adana, Türkiye, e-mail: scanturk@cu.edu.tr  
 <https://orcid.org/0000-0001-6055-7191>

<sup>4</sup>(Res. Asst.), Çukurova University, Faculty of Agriculture, Department of Horticulture, Adana, Türkiye, e-mail: mada@cu.edu.tr  
 <https://orcid.org/0000-0001-5182-0787>

### 1. Introduction

According to the OIV report, 73.3 million tons of grapes are produced approximately in 7.5 million hectares of vineyard area, globally (OIV 2019). The world vineyard area is dominated by Spain, China, France, Italy, and Türkiye (448.000 ha). The major grape producers, ranked by their production in the volume are China, Italy, the USA, France, Spain, and Türkiye (4.2 million tons). Global table grape production was 27.3 million tons and generated mainly by China (9.5 million tons), Türkiye (1.9 million tons), India (1.9 million tons), Iran (1.7 million tons), and Egypt (1.5 million tons). Viticulture is devoted to table grape production as 36% globally and 57% in Türkiye (OIV 2019).



Along with the increasing world population, the improvement in living standards in many countries has led to a demand for high-value fruits, vegetables, ornamental plants, medicinal and aromatic plants, especially high-quality, off-season products. This demand provides the development and spread of greenhouse production techniques using materials ranging from glass greenhouses to plastic covers, with the limited agricultural lands and the effects of scientific, economic, and technological developments worldwide. However, increasing the yield per unit area has become compulsory to cover the production expenses, which are higher in greenhouse cultivation than conventional. In agriculture, one of the most important cultural practices required to increase the yield per unit area is sufficient nutrients in the plant growing medium. Although it has a 10-15% share in input prices in agricultural production, it is known that fertilization alone increases the yield up to 50% (Demirtaş *et al.* 2012). Therefore, there is a need to develop new techniques that allow more effective plant nutrition.

## 2. Cultivation of Table Grapes in Soilless Culture

Soilless cultivation is one technique that increases the yield per unit area in greenhouse production and reduces the use of fertilizers and water, which is an important goal of sustainable production in many horticultural crops. Soilless cultivation technique was first used in 1930 by British researcher Prof. Dr. William Gericke and then was developed in the Netherlands. Di Lorenzo *et al.* (2013) stated that the first soilless cultivation studies started in Italy, one of the important grape growing countries, in the 1960s, and the increased to 40-50 ha in the 1990s and 400 ha in 2000, and after about ten years, 5-7% of horticultural crops cultivation in the greenhouse is composed of soilless cultivation. The countries that come to the fore in soilless agriculture are Netherlands and Spain. Soilless agriculture activities in Türkiye started in an area of 10 ha in Antalya in 1995 and reached 1200 ha in 2016 (Gül 2017 and 2019; Tüzel *et al.* 2020).

Soilless culture is a plant growing method in which the plant is nourished by the application of an appropriate nutrient solution in a growing medium that does not contain soil in the root zone (Savvas & Gruda 2018; Gül 2019; Raviv *et al.* 2019; Tüzel *et al.* 2019). It is a suitable technique for intensive production, thanks to controlled irrigation and plant nutrition (Raviv *et al.* 2019). Different methods range from substrate culture using perlite, zeolite, pumice, vermiculite, rock wool, sand, sawdust, peat, cocopeat, compost, etc., to the hydroponic system using only water and nutrient solution (nutrient film technique, etc.) (Tüzel *et al.* 2019).

Soilless culture aims to meet the water and nutrient needs of the plants by using nutrient solutions prepared so that the plants will not be stressed. It is a technique that may be used in places with no soil or unsuitable for plant cultivation (disease and pest contamination, stony, rocky areas, high lime, high or low pH, near the sea salty areas, deserts, etc.). It is also preferred because it provides a suitable physical and chemical environment in the plant root zone, minimizes the risks in production, and increases quality and yield.

Although soilless culture systems were initially developed for vegetables and ornamental plants, they are also used to cultivate grapes (Di Lorenzo *et al.* 2013; Buttaro *et al.* 2012; Tangolar *et al.* 2017, 2018, 2019 a,b,c), some fruits (Melgarejo *et al.* 2007; Schuch & Peil 2011; Di Lorenzo *et al.* 2013; Rubio-Asensio *et al.* 2018; Tagliavini *et al.* 2005; Beyer *et al.* 2021). In recent years, it has been seen that table grape cultivation has been adapted to soilless culture due to its various advantages. The main of these advantages are; (1) to be able to obtain productive and high-quality products even in infertile soils, (2) no need for tillage and soil preparation, (3) no need for soil sterilization and base dressing, (4) protection from soil pathogens, (5) obtaining high yields by growing grape varieties on their own roots without the need for grafting onto the rootstock, (6) more controlled and more efficient use of water and nutrients, (7) reducing spraying, (8) no need for herbicide application, (9) reducing cultural practices, (10) obtaining higher quantity and quality of product per unit area due to frequent planting (10000-16000 plants ha<sup>-1</sup>), (11) obtaining two crops in one year, (12) production of new or traditional grape varieties in a wider period according to market demands, (13) control of harvest time (early or late ripening) (Di Lorenzo *et al.* 2005, 2009, 2012; 2013; Buttaro *et al.* 2012).

Despite the advantages mentioned above of soilless cultivation; (1) high input and energy costs, (2) environmental problems (disposal of exhausted substrates such as rock wool, losses in the soil of draining nutrient solution, use of vast amounts of plastics), (3) no indications for the distribution of pesticides with the nutrient solution, (4) dependence on electricity and other economic sectors, (5) requiring a high level of technical knowledge and skills (Di Lorenzo *et al.* 2013). It has been stated that the relatively high organization cost of the soilless cultivation system can only be tolerated in Mediterranean countries (Savvas *et al.* 2013).

Grape cultivation in soilless culture, when considered together with greenhouse grape cultivation, seems to be an important cultivation method thanks to the above-mentioned advantages. It is thought that this technique may be used in both early and late-ripening grape varieties. As far as we know, no

breeder cultivates grapes in soilless culture commercially in Türkiye. Studies on this subject are carried out in department of horticulture of various universities and viticultural research institutes.

### 3. Variety Selection for Soilless Cultivation

Some of the early ripening grape varieties recommended for greenhouse cultivation, which started in the 1990s in the Mediterranean region; Yalova İncisi, Trakya Ilkeren, Early Cardinal, Ergin Çekirdeksizi, and Vittoria (Gök Tangolar *et al.* 2007; Tangolar *et al.* 2011; Tangolar 2016). Prima, Early Sweet, and Black Magic are suitable varieties that have been observed to be appreciated by producers in recent years (Baştaş & Tangolar 2018; Tangolar *et al.* 2019 a,b). Early ripening grape varieties are harvested in the first weeks of Jun when grown open field and in mid or late May when grown greenhouse in the Mediterranean region. Favorable results were obtained from soilless cultivation with Early Cardinal, Early Sweet, Yalova İncisi, Prima, Trakya Ilkeren, Black Magic (Tangolar *et al.* 2017, 2019 a,b,c; Baştaş & Tangolar 2018) and Perle de Csaba, Italia and Alphonse Lavallée (Sabir *et al.* 2016 and 2017) in Türkiye; Vittoria, Black Magic, Matilde, Red Globe, Regal Seedless, Doria Seedless and Early Cardinal in Italy (Di Lorenzo *et al.* 2005, 2009, 2012, 2013; Buttaro *et al.* 2012; Ruggiero *et al.* 2012) and Sultani Çekirdeksiz in Iran (Zareei *et al.* 2021).

### 4. Substrates Used in Soilless Culture

One of the critical reasons for the development of soilless cultivation is the increase of soil-borne pathogens in greenhouses where intensive cultivation is carried out and the high cost of their control. Organic (peat, compost, sawdust, bark) and inorganic (gravel, pumice, perlite, rock wool, zeolite, and vermiculite) substrates, which are used instead of soil, are almost free of pests and diseases; this is one of the important reasons for choosing the soilless culture technique. In addition, the ability to clean and disinfect these materials from microorganisms is seen as an important advantage for reuse in the next year. It has been reported that the physical and hydraulic properties of most substrates are superior to the soil. Another advantage of substrates used in hydroponic cultivation is that the uptake and use of water and nutrients through roots could be better controlled than in soil.

Affordability, accessibility, and usability are essential features considered in selecting substrates in various countries (Maher *et al.* 2008; Papadopoulos *et al.* 2008; Raviv & Lieth 2008). Bringing together mixes that will perform to

the desired performance at the lowest overall cost is one of the most common challenges faced by growers in various countries. A good soilless growing medium in which substrates are single or mixed; should have some physical and chemical properties. It should be well-drained and have a homogeneous texture that can hold air, water, and nutrients for the root system. It should be lightweight, porous (50 - 85%), has an easily adjustable pH of 5.0 - 6.5, and has low soluble salt content. It should be free from pathogens and should not contain any phytotoxic compounds for vines (Raviv *et al.* 2019; Tüzel *et al.* 2019). In future studies, it is important to compare the substrates with the control medium in terms of their capacity to hold and release water and nutrients and evaluate them in terms of affordability.

Among the different soilless cultivation techniques (Gül 2019; Raviv *et al.* 2019; Tüzel *et al.* 2019), the main technique used in Türkiye is substrate culture, commonly used substrates are perlite, pumice, rock wool, peat, and coconut peat. While perlite is locally available, rockwool and coconut peat are imported (Gül 2017; Tüzel *et al.* 2019). It has been shown that pumice may also be used effectively as a local resource for Türkiye (Baştaş & Tangolar 2018). Substrate culture is mostly used in table grape cultivation. The properties of some substrates used alone or in mixtures in soilless culture grape cultivation are presented below:

**4.1 Peat:** Peat is an organic material that is a critical component of plant growing media in Europe and North America due to its easy handling and excellent properties. It has high porosity, well-draining, and high water-holding capacity. The low pH (3.5-4.1) and nutrient content may be brought to the desired level by adding lime and fertilizer. Due to its lightweight, transportation is inexpensive. It is physically relatively stable when used as a growing medium. After using it in soilless culture, it may be used as a soil conditioner; there is no waste problem. Peat stratum in the world is found in Finland, Germany, Canada, and Ireland. Türkiye is not rich in high quality peat stratum (Maher *et al.* 2008), but there are peat stratum Kars/Göle and Bolu/Yeniçağ (Sevgican 2003; Çinkılıç 2008).

**4.2 Cocopeat:** Cocopeat is also known as coconut peat. Since this medium is not found in Türkiye, it is imported from India, the Philippines, Indonesia, Sri Lanka, and Latin American countries. It is a fibrous and organic material obtained from the *Cocos nucifera* (coconut) tree. It is made ready for use by chopping the coconut fruit peels, disinfecting, pressing, and packaging. It is marketed as 5-25 kg pressed blocks for easy transportation. It has a water-holding capacity of 5-9 times its own volume. Due to the low nutrient content,

the plant nutrients required for soilless cultivation must be added externally. In addition to its slow decay, cocopeat is an organic material that is very suitable for recycling as it contains 94-98% organic matter in its dry weight, and its pH is 5.5-6.5 (Kasım & Kasım 2004; Gül 2019). Nelson *et al.* (2004) showed that cocopeat is physically more stable than peat. Fornes *et al.* (2003) attributed the differences in physical properties of cocopeat and peat to their microstructure and porosity. They stated that the fiber particles had a much higher surface porosity (41%) than peat (12%).

**4.3 Compost:** The physical and chemical properties of composted materials depend on the materials used. A study on compost determined that the N contents of mushroom compost samples from various countries were similar (Noble 2005). Onion waste was determined to have the lowest lignin and highest soluble carbohydrate content, possibly due to a shorter composting time. Compost made from grape wastes was found to be woodier than those made from other wastes. In composts made with various materials in various countries (Noble 2005), it has been determined that the dry weight ranged between 25.5% and 83.4%, the pH ranged between 5.7-8.4, and the EC ranged between 94-549 mS/m. It has been found that the moisture content and K concentration of composts prepared from vegetal wastes are higher than other composts (Maher *et al.* 2008).

**4.4. Perlite:** Perlite is a local material, and more than half of the world's perlite reserves are in Türkiye. There are perlite reserves in Bayburt, Erzurum, Kars, Muş, Van and Iğdır in Eastern Anatolia, in Ankara and Nevşehir in Central Anatolia, and in Balıkesir and İzmir in the Aegean Region. It is a material obtained by exploding volcanic rocks by exposing them to temperatures of 900 - 1000°C all at once. There is no waste problem and could be used for a long time by sterilizing when necessary. Its water holding capacity is quite high (229-360), its volume weight is 0.389 g/cm<sup>3</sup>, its EC is 0, and its pH is 6.5-7.5. Since its thermal conductivity is low, plants are not negatively affected by daily temperature changes. Perlite is a material 90% of which consists of air spaces; its porosity is more than 60%. 5-10% of the perlite produced globally is used in agriculture (Sevindi 2003).

**4.5 Pumice:** Pumice; it is a very porous, sponge-like silicate-based volcanic rock. Chemically, the silica content can reach up to 75% (Elmastaş 2012; MTA 2021). It has two types, acidic and basic, and the type used in agriculture is the basaltic one. Basaltic pumice with dark, brownish, blackish colors is also called basic pumice or volcanic tuff. Türkiye has significant potential in terms of pumice reserves. Most of the pumice reserves in Türkiye are located in

Isparta, Burdur, Muğla, Bitlis, Kayseri, Nevşehir Ağrı, Kars and Van provinces (Elmastaş 2012; MTA 2021). Since pumice preserves the water for a long time and provides a moist medium, it proposes a partial solution to drought, and is so widely used (Özkan & Tuncer 2001). The water absorption rate of pumice is more than 50% (İlhan & Özdağ 1997); it is an ideal growing medium for soilless agriculture that may give the water it holds depending on the needs of the plants (Tangolar *et al.* 2019). The particle size of pumice to be used in the agricultural sector is mostly <8mm (Gizas & Savvas 2007).

**4.6 Zeolite:** Zeolites; are defined as porous, hydrated aluminum silicate crystals. It is reported to reduce water use by 10-12% (Demir & Polat 2003). Zeolites found in about twenty regions in Türkiye, especially in Western Anatolia, are primarily in acid composition tuffic rocks. The most common and economically important zeolite mineral is clinoptilolite. It is a substrate that is suitable for reuse; its physical properties do not change over time. The substrates mentioned above do not pose a waste problem. They are materials that may be used in landscaping and soil improvement (Özün & Sivrikaya 2018) after being used in soilless culture grape cultivation.

Studies have been conducted to determine the most suitable growing medium in soilless culture table grape cultivation (Tangolar *et al.* 2019b). Sabır *et al.* (2020) used perlite: peat (1:1) mixture; Baştaş & Tangolar (2018) used cocopeat, perlite: peat (2:1) mixtures and basaltic pumice; Tangolar *et al.* (2017 and 2018) used a mix of cocopeat and perlite: peat (2:1); Buttaro *et al.* (2012) used perlite: peat (2:1) mixtures and obtained favorable results.

## 5. Containers Used in Soilless Culture

Although it is possible to use logline, grow bag, or plastic bag as containers in soilless culture grape growing, the pots with a volume ranging from 3.5 to 40 L are mostly used, and favorable results are obtained. Di Lorenzo *et al.* (2003) used 3.5 L, Polat *et al.* (2003), Kaya *et al.* (2018) and Tangolar *et al.* (2017; 2019a,b,c) used 32 L; Sabır *et al.* (2016) used 40 L, Buttaro *et al.* (2012) used 10 L and Zareei *et al.* (2021) used 20 L pots in their studies.

The choice of pot sizes depends on the variety, substrate, length of the vegetation, and period of use. Appropriate pot size allows plants to be grown in the smallest root volumes, reducing substrate costs, and placing more plants per unit area. In this context, it is aimed to reach sufficient root volume and a high growth rate via appropriate fertilization that provides water and nutrients that may be taken in adequate quantities.

The choice of container depth depends on the plant species, the length of the growth cycle, and the substrate. It has been shown that the depth of the containers has a more significant effect than the volume on successful plant growth (Dominguez-Lerena *et al.* 2006). Containers are generally preferred to be deeper than 20 cm. The drip irrigation system is used to provide a nutrient solution for each plant individually, and drainage is usually supplied by the overflow opening at the bottom of the container. The growing media mainly used in pot culture studies are cocopeat, perlite, pumice, and their mixtures (Savvas *et al.* 2013; Kaya *et al.* 2018; Tüzel *et al.* 2019; Tangolar *et al.* 2017, 2019a,b,c).

## 6. Nutrient Solutions Used in Soilless Culture

The growing medium, formulation, and application of the nutrient solution are the essential variables of the soilless culture technique. Substrate culture is widely used in soilless culture grape cultivation. In this culture, the water and nutrient requirements of the vines are met by the drip irrigation system. The nutrient solution is applied so that approximately 10-30% drainage is obtained (Gül 2019). The water holding capacity of the growing medium, its EC, and the total water consumption (L or mm) of the vine during the vegetation period are considered in determining the irrigation time and amount. In recent years, it has been reported that the irrigation method depending on the light intensity value in joules used in soilless culture production of some vegetables may also be effective (Gül 2019).

In soilless culture cultivation, the nutrient solution is applied by two systems. The first is the open system, where the nutrient solution is discharged directly out of the system after it is used in the soilless culture system. The second is the closed system, where the nutrient solution that enters the system is disinfected for reuse and reintroduced to the soilless culture system by completing the decreasing nutrient elements and adjusting the salinity (Electrical conductivity) (Winsor & Schwarz 1990).

In greenhouse cultivation in a closed system, nitrate and phosphate pollution caused by fertilization is reduced, and this provides a significant reduction in water and fertilizer use (Schröder & Lieth 2002). Although the closed cultivation system does not cause a decrease in the yield and quality of the product, the salt accumulated in the recycling of the nutrient solution may be considered as a limiting factor in plant cultivation in the substrate medium. This factor is related to the salt ions in the irrigation water (Santamaria *et al.* 2003). In addition, it is necessary to establish a disinfection system to recycle the water of the waste nutrient solution in a closed system (Öztekin *et al.* 2003).



In soilless systems, higher water and nutrient concentrations are generally recommended to ensure the meet of plant's nutritional needs. In these systems, more concentrated nutrients are required, as the buffer conditions such as ion exchange, absorption-deabsorption, dissociation, and precipitation are not as good as soil (Di Lorenzo *et al.* 2013). Most studies on soilless grape growing use Hoagland nutrient solution or modified forms (Hoagland and Arnon, 1950). The nutrient solutions and concentrations used in the studies are given in Table 1 (Tangolar *et al.* 2017 and 2019c; Baştaş & Tangolar 2018; Kaya *et al.* 2018; Atalan 2020; Buttaro *et al.* 2012; Zareei *et al.* 2021). The authors reported that the nutrient solutions they used did not have any negative effect and could be used in different studies. The macroelement concentrations used by Di Lorenzo *et al.* (2013) in Centennial, Matilde, Perlon, and Victoria cultivars are given in Table 2. The nutrient solutions used by the same researchers and the amounts of water and minerals per vine in the vegetative and crop cycles are given in Table 3 and 4. Buttaro *et al.* (2012) used different nutrient solutions given in Table 5 to determine the effects of reducing some macroelements in the Hoagland nutrient solution by 30%. The total concentration of macro and microelements used by Baştaş (2017) in the vegetative and crop years is given in Table 6. The amount of water applied per vine in phenological periods by Baştaş (2017) is given in Table 7.

## 7. Cultivation Technique of Grapes in Soilless Culture

### 7.1. Vegetative cycle: Obtaining plant material (1<sup>st</sup> year)

In the first year of soilless culture grape cultivation, the plants are grown in the open field. This year, it is essential to obtain a healthy, productive shoot with standard sizes and a well-lignified cane (Figure 1). For this purpose, two-five bud cuttings with 7-10 mm diameter, well lignified, healthy canes are prepared in January-March, are irrigated, and rooted in perlite (Tangolar *et al.* 2017; Baştaş & Tangolar 2018) or peat. (Buttaro *et al.* 2012). Rooted plants are transferred to 3.5-40 L pots containing a suitable substrate after 1-2 months (March-April) (Di Lorenzo *et al.* 2003; Buttaro *et al.* 2012; Tangolar *et al.* 2019 a,b,c; Baştaş & Tangolar, 2018; Sabır *et al.* 2016 and 2017). Following the transfer process, nutrient solution application is started with irrigation. Shoots were topped in 1.80 cm, and the lateral shoots below were removed (Table 8). This application provides thickening and lignification of the shoots (Baştaş & Tangolar 2018). Di Lorenzo *et al.* (2003) reported that shoots with 25-30 mm diameter are more productive.

## 7.2. Crop cycle: Grape production (2<sup>st</sup> year)

The canes obtained at the end of the first year are pruned to a length of 1-1.5 m and transferred to the plastic greenhouse in January-February, following defoliation (Tangolar *et al.* 2017) (Figure 2). It is appropriate to grow the vines in Guyot (one-armed, two-armed, or twisted Guyot) (Tangolar *et al.* 2019 a,b,c; Atalan 2020), vertical cordon (Polat *et al.* 2003), or tendone system at 0.40-0.75 m x 1.5-2.0 m row spacing (Tangolar *et al.* 2019 a,b,c; Buttaro *et al.* 2012) i.e. with density of 7000-15000 vine in per hectare. Plants are fertilized with a suitable nutrient solution using a drip irrigation system as from bud burst. Fertilization is continued as 1-3 L pot<sup>-1</sup> per day, depending on the needs of the plants. It is recommended that the pH of the nutrient solution is 5.5-6.0 and that 10-30% of it should be drained (Tangolar *et al.* 2019a,b,c; Buttaro *et al.* 2012). The working schedule for the crop year is given in Table 8.

## 8. The Yield of Table Grapes in Soilless Culture

In the studies on soilless table grape production, the authors determined that productive and high-quality grapes in accordance with international market standards could be obtained. The findings concluded that the cultivars grown in soilless culture could reach higher yield and acceptable quality than those grown under traditional conditions. Some of these studies are given below:

Di Lorenzo & Mafrika (2000) and Di Lorenzo *et al.* (2009 and 2012) reported that 40 t ha<sup>-1</sup> yield could be obtained in table grape cultivation in soilless culture. In their study, it has been shown that crops were obtained twice a year, the first cycle between January and June and the second cycle between July and October. Black Magic and Victoria cultivars were grown in two production cycles in the same greenhouse in the same year, and a total yield of 60 and 70 t ha<sup>-1</sup> was obtained from the two cycles, respectively.

In two experiments of Buttaro *et al.* (2012) conducted in Italy, yield, and cluster weight in the first experiment were 21.7 t ha<sup>-1</sup> and 419 g, respectively; in the second experiment, it was determined as 29.4 t ha<sup>-1</sup> and 689 g.

Di Lorenzo *et al.* (2013) reported that 39 and 45 t ha<sup>-1</sup> grape was obtained in the first cycle in Vittoria and Black Magic grape cultivars, and a total of 78 and 67 t ha<sup>-1</sup> in two cycles.

In the study of Tangolar *et al.* (2017), the highest yield was determined in the second and third crop years in Prima as 58.8 t ha<sup>-1</sup> and 37.3 t ha<sup>-1</sup> and in Trakya Ilkeren as 58.4 t ha<sup>-1</sup> and 35 t ha<sup>-1</sup> respectively.

Baştaş & Tangolar (2018) obtained approximately 35 t ha<sup>-1</sup> yield with 20 clusters/vine from Prima cultivar grown in the soilless culture. Kaya *et al.*

(2018) obtained a yield of 4875 gr vine<sup>-1</sup> (43.3 t ha<sup>-1</sup>) and 2703 gr vine<sup>-1</sup> (24 tons ha<sup>-1</sup>) from 2- and 3-year-old Yalova İncisi cultivars, respectively. In Prima, the yield of 2 and 3-year-old vines was determined as 4252 g vine<sup>-1</sup> (37.8 t ha<sup>-1</sup>) and 3984 g vine<sup>-1</sup> (35.4 t ha<sup>-1</sup>), respectively.

Table 1. Some nutrient solutions used in the studies of soilless culture table grape cultivation (ppm)

Mineral	A	B	C	D	E	F
N	210	100	150	100 and 200	150	224
P	31	20	30	20	30	62
K	234	150	175	75 and 150	175	235
Mg	48	20	20	20	20	24
Fe	2.5	5	5	5	5	1.12
Mn	0.5	3	3	3	3	0.11
B	0.5	0.4	0.4	0.4	0.4	0.27
Cu	0.02	0.2	0.02	0.2	0.02	0.03
Zn	0.05	1	1	1	1	0.13
Mo	0.01	0.05	0.05	0.05	0.05	0.05

A: Atalan (2020); Hoagland & Arnon (1950); Zareei *et al.* (2021), (Hoagland solution)

B: Tangolar *et al.* (2017); Baştaş & Tangolar (2018); Tangolar *et al.* (2019a)

C: Kaya *et al.* (2018)

D: Tangolar *et al.* (2019b)

E: Tangolar *et al.* (2019c)

F: Tangolar *et al.* (2019c); Buttaro *et al.* (2012)

Table 2. Concentration ranges of macronutrients (mM) in soil and soilless plants (Di Lorenzo *et al.* 2013)

Nutrient	Soil	Soilless
N-NO <sub>3</sub> <sup>-</sup>	0.5-10 (usually ) <1-2)	5-20
N-NH <sub>4</sub> <sup>+</sup>	0.02-0.05	0.5-2
P (H <sub>2</sub> PO <sub>4</sub> <sup>-</sup> )	0.005-0.05	0.5-2
K <sup>+</sup>	0.2-2	5-10
Ca <sub>2</sub> <sup>+</sup>	0.5-4	3-6
Mg <sup>2+</sup>	0.2-2	1-2
S (SO <sub>4</sub> <sup>2-</sup> )	0.1-2	1.5-4

N-NO<sub>3</sub><sup>-</sup>, nitrogen as nitrate ion; N-NH<sub>4</sub><sup>+</sup>, nitrogen as ammonium ion; P (H<sub>2</sub>PO<sub>4</sub><sup>-</sup>), phosphate as dihydrogen phosphate ion; K<sup>+</sup>, potassium; Ca<sup>2+</sup>, calcium; Mg<sup>2+</sup>, magnesium; S (SO<sub>4</sub><sup>2-</sup>), sulfur as sulfate ion.

Table 3. Quantity of water (L) and mineral elements (g) for each plant during the vegetative and crop cycle (Di Lorenzo et al. 2003)

Water	N	P	K	Mg	Fe	Mn	Zn
580	29.2	7.8	34.8	18.3	1	0.3	0.2

Table 4. Composition of the different nutrient solutions ( $\text{mgL}^{-1}$ ) (Di Lorenzo *et al.* 2003)

Nutrient solution	N	P	K	Mg	Fe	Mn	Zn
1	44.25	10.98	42.50	25.66	5.31	0.66	0.33
2	103.50	30.60	137.0	52.71	0.53	1.06	0.53
3	36.86	9.18	44.39	30.43	0.16	0.32	0.16

Table 5. Nutrient solutions with some macroelement concentrations reduced by 30% (Buttaro *et al.* 2012)

Nutrient solution (NS)	N	P	K <sup>+</sup>	Ca <sup>2+</sup>	Mg <sup>2+</sup>
	mM				
NS1 (Hoagland-type)	16.0	2.0	6.0	4.0	1.0
NS2 (Hoagland - 30% N, P, K, Ca, and Mg)	11.2	1.4	4.2	2.8	0.7
NS3 (Hoagland - 30% N and P)	11.2	1.4	6.0	4.0	1.0
NS4 (Hoagland - 30% N, P, Ca, and Mg)	11.2	1.4	6.0	2.8	0.7

Table 6. Quantity of mineral elements in different years used for each plant (Baştaş 2017)

Years	N	P	K	Mg	Fe	Zn	Mn	B	Mo
	g kg <sup>-1</sup>				mg kg <sup>-1</sup>				
1 <sup>st</sup> Year: Vegetative cycle	10.9	2.34	12.5	2.92	722	130	238	52	2.25
2 <sup>nd</sup> Year: Crop cycle	14.8	3.19	17.0	3.99	986	178	325	71	3.08

Table 7. Quantity of water according to the phenological phases (L vine<sup>-1</sup>) (Baştaş 2017)

Phenological phase	Prima	Early Sweet
	Cocopeat	
Bud Break-Bloom	14.00	10.50
Bloom-Veraison	50.50	57.50
Veraison-Harvest	68.25	46.50
Perlite: Peat (2:1)		
Bud Break-Bloom	17.50	12.50
Bloom-Veraison	62.00	70.00
Veraison-Harvest	74.75	49.50
Basaltic Pumice		
Bud Break-Bloom	14.50	11.00
Bloom-Veraison	47.50	54.50
Veraison-Harvest	64.75	44.25

Table 8. Vineyard management during the vegetative and crop cycle

	Jan.	Feb.	Mar.	Apr.	May	Jun.	Jul.
1 <sup>st</sup> Year: Vegetative cycle							
Rooting of cuttings	X	X	X				
Transferring to pots			X	X			
Lateral shoot removal					X	X	X
Topping							X
2 <sup>nd</sup> Year: Crop cycle							
Pruning	X	X					
Training and tying		X					
Cluster thinning			X	X	X		
Leaf removal				X	X		
Ripening and harvest						X	X

In the study of Tangolar *et al.* (2019a), the highest grape yield (38 t ha<sup>-1</sup>) of Early Sweet cultivar grown in soilless culture was obtained from perlite:peat

mixture and 15 clusters/vine. Basaltic pumice, an easily acquirable and cheap material, has also been suggested because of its acceptable yield levels. In another study by Tangolar *et al.* (2019c) the highest yield and cluster weight were obtained from pumice in Early Sweet (2066 g vine<sup>-1</sup> (18.3 t ha<sup>-1</sup>) and 344.4 g, respectively); and from perlite:peat in Trakya Ilkeren (1981 g vine<sup>-1</sup> (17.6 t ha<sup>-1</sup>) and 495.1 g, respectively).

## 9. Conclusion

Soilless growing system is still applied in the field of vegetables and ornamental plants on a large scale in the world and in Türkiye. However, studies have shown that significant advantages may also be obtained with the use of this technique in table grape cultivation. In soilless grape growing researches, the subject has been discussed in terms of choice of suitable varieties, the substrates used, the containers used, the nutrient solutions, the growing techniques and the grape yield. As a result, it was concluded that soilless cultivation may be used commercially by grape producers in suitable ecologies.

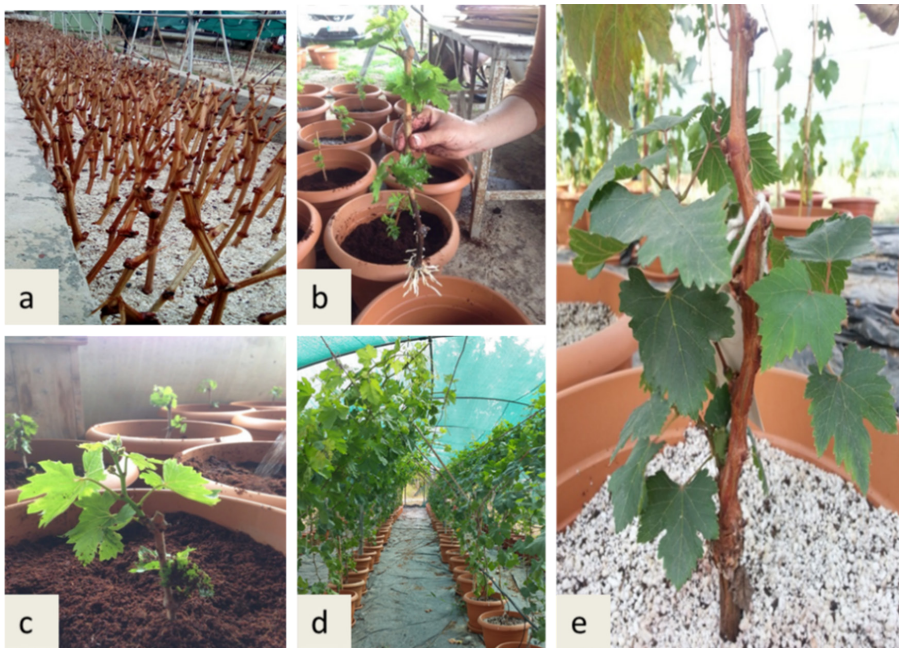


Figure 1. Vegetative cycle: a. Planting of cuttings, b. Rooted cuttings, c. Transferring of rooted cuttings into the pots (April-May), d. Shoot growth and lignification





Figure 2. Crop cycle: a, b, c. Training of the vines, a. Vertical cordon, b. One-armed Guyot, c. Twisted Guyot, d. Cv. Black Magic, e. Cv. Yalova İncisi, f. Cv. Early Cardinal

## References

- Atalan M (2020). Topraksız kültürde yetiştirilen early cardinal üzümünde farklı ortam, kimyasal ve organik gübre uygulamalarının verim ve kaliteye etkileri. Master thesis, Çukurova University, Graduate School of Natural and Applied Sciences Department of Horticulture 107 p.
- Baştaş P (2017). Topraksız kültür ortamında yetiştirilen sofralık üzüm çeşitlerinde ortam ve ürün yüklerinin verim ve bazı kalite özelliklerine etkisi. Master thesis, Çukurova University, Graduate School of Natural and Applied Sciences Department of Horticulture 149 p.
- Baştaş P C & Tangolar S (2018). The effect of growing medium and crop loads on yield and some quality properties of prima grape cultivar grown in soilless culture (English abstract). *Alatarım* 17 (2): 98-109.
- Beyer C P; Cuneo I F; Alvaro J E; & Pedreschi R (2021). Evaluation of aerial and root plant growth behavior, water and nutrient use efficiency and carbohydrate dynamics for Hass avocado grown in a soilless and protected growing system. *Scientia Horticulturae* 277, 109830.



- Buttaro D; Serio F & Santamaria P (2012). Soilless greenhouse production of table grape under mediterranean conditions. *Journal of Food, Agriculture & Environment* 10 (2): 641-645.
- Çinkılıç H (2008). Propagation of cucumber seedlings in different organic and inorganic media (English abstract) *Journal of Tekirdag Agricultural Faculty* 5(2): 151-158.
- Demir H & Polat E (2003). Zeolit (klinoptiolit) ve tarımda kullanımı. *Hasad* 221: 54-59.
- Demirtaş E Öktüren I; Asri F; Özkan C F & Arı N (2012). Effects of organic and chemical fertilizer on plant nutritional status and soil fertility of tomatoes grown under greenhouse condition. *Derim* 29 (1): 9-22.
- Di Lorenzo R & Mafra R (2000). Soilless cultivation of dessert grapes: initial results from Sicily. *Rivista di Frutticoltura e di Ortofloricoltura* 62(3), 48-53.
- Di Lorenzo R; Barbagallo M G; Costanza P; Gugliotta E; Palermo G; Mafra R & Di Mauro B (2003). Cultivation of table grapes in “soilless” in Sicily. *Proc. 6th IS on Protected Cult.* Eds: G. La Malfa *et al.* *Acta Hort* 614: 115-122.
- Di Lorenzo R; Dimauro B; Guarasci F; Rinoldo C & Gambino C (2012). Multiple Productive cycles in the same year in soilless table grape cultivation. P 20 in *Proc. 35th Word Congr. Vine and Wine, Izmir, Türkiye.*
- Di Lorenzo R; Gambino C & Dimauro B (2005). Soilless cultivation in the table grape cultivation. *Convegno Nazionale “Strategie Per İl Miglioramento Dell’orticoltura Protetta İn Sicilia”.* Scoglitti (Rg). 25-26 Novembre, 53-64 p.
- Di Lorenzo R; Gambino C & Dimauro B (2009). La Coltivazione Dell’uva Da Tavola in Fuori Suolo: Stato Attuale E Prospettive. *Bull. OIV*, 82: 935-7.
- Di Lorenzo R; Pisciotta A; Santamaria P & Scariot V (2013). From soil to soil-less in horticulture: quality and typicity. *Italian J. of Agronomy* 8- E30: 255-260.
- Dominguez-Lerena S; Sierra N H; Manzano I C; Bueno L O; Rubira J P & Mexal J G (2006). Container characteristics influence *Pinus pinea* seedling development in the nursery and field. *Forest Ecology and Management* 221(1-3): 63-71.
- Elmastaş N (2012). A mine becoming increasingly important for economy of Türkiye: pumice. *The Journal of International Social Research* 5(23):197-206.
- Fornes F; Belda R M; Abad M et al (2003). The microstructure of coconut coir bust for use as alternative to peat soilless growing media. *Aust. J. Exptl. Agric.* 43: 1171–1179.

- Gizas G & Savvas D (2007). Particle size and hydraulic properties of pumice affect growth and yield of greenhouse crops in soilless culture. *Hortscience* 42(5): 1274-1280.
- Gök Tangolar S; Tangolar S; Bilir H; Özdemir G; Sabır & Çevik B (2007). The effects of different irrigation levels on yield and quality of some early grape cultivars grown in greenhouse, *Asian J. of Plant Sci.* 6, 4, 643-647.
- Gül A (2019). *Topraksız tarım* (3. Baskı). Hasad Yayıncılık, ISBN 978-975-8377-83-1, İzmir, 146 s. [in Turkish].
- Gül A (2017). Soilless cultivation in Türkiye. *Chronica Horticulturae* 57 (3): 23-27.
- Hoagland D R & Arnon D I (1950). The water-culture method for growing plants without soil. *California Agricultural Experiment Station Circular* 347:1-32.
- İlhan S & Özdağ H (1997). Determination of some physical and chemical characteristics of pumice particles (English abstract). *Madencilik* 36(2-3):25-34.
- Kasım R & Kasım U (2004). *Topraksız yetiştiricilik*. Kocaeli Üniv. Yayınları No: 130.
- Kaya S; Tangolar S & Tangolar S (2018). The effect of root pruning applications on yield and quality of some table grape varieties grown in different solid culture media (English abstract). *Bahçe* 47 (Special issue 1: Türkiye 9. Bağcılık Teknolojileri Sempozyumu): 575-585.
- Maher M; Prasad M & Raviv M (2008). Organic soilless media components. *Soilless culture: Theory and practice* 459-504.
- Melgarejo P; Martínez J J; Hernández F; Salazar D M & Martínez R (2007). Preliminary results on fig soil-less culture. *Scientia Horticulturae* 111(3), 255-259.
- MTA (2021). Pomza. <https://www.mta.gov.tr/v3.0/bilgi-merkezi/pomza>. Date accessed: August 13, 2021.
- Nelson P V; Oh Y M & Cassel D K (2004). Changes in physical properties of coir dust substrates during crop production. *Acta Hort.* (ISHS) 644: 261-268.
- Noble R (2005). Recycling horticultural wastes to produce pathogen suppressant composts for sustainable vegetable production. Final Report of EU FP5 project QLRT-CT-01458 RECOVEG. Warwick HRI, University of Warwick, UK.
- OIV (2019). OIV Statistical Report on World Vitiviniculture <http://www.oiv.int/public/medias/6372/oiv-2019-statistical-report-on-world-vitiviniculture.pdf>. Date accessed: December 26, 2019.

- Özkan G & Tuncer G (2001). A general overview of pumice mining (English abstract), 4. Endüstriyel Hammaddeler Sempozyumu, 18-19 Ekim 2001, İzmir, Türkiye, Sy: 200-207.
- Öztekin G; Tüzel Y & Keskin Ö (2003). Disinfection of nutrient solution in soilless culture. *Alatırım* 2(2): 34-39.
- Özün S & Sivrikaya O (2018). Pumice as industrial raw material: importance, properties, and use (English abstract). 3<sup>rd</sup> International Mediterranean Science and Engineering Congress October 24-26, 2018, Adana-Türkiye. Pages: 1471-1476.
- Papadopoulos A P; Bar-Tal A; Silber A; Saha U K & Raviv M (2008). Inorganic and synthetic organic components of soilless culture and potting mixes. *Soilless culture, theory and practices*. Elsevier Science Amsterdam, 505-543.
- Polat İ; Özkan C F; Kaya H & Eski H (2003). Topraksız kültür üzüm yetiştiriciliğinde farklı ortamların erkencilik, kalite ve verime etkisi. Türkiye 4. Ulusal Bahçe Bitkileri Kongresi, 493-496, 08-12 Eylül, Antalya. [in Turkish].
- Raviv M & Lieth J H (2008). Significance of soilless culture in agriculture. *Soilless culture theory and practice*, 1-11.
- Raviv M; Lieth H & Bar-Tal A (2019). *Soilless culture: theory and practice*. Elsevier. ISBN: 9780444636966. 712 p.
- Rubio-Asensio J S; Franch V; López F; Bonet L; Buesa I & Intrigliolo D S (2018). Towards a near-soilless culture for woody perennial crops in open field conditions. *Scientia Horticulturae* 240: 460-467.
- Ruggiero C; Di Lorenzo R; Angelino G; Scaglione G; Gambino C & Di Vaio C (2012). Root hydraulic conductivity in three self-rooted and grafted table grape cultivars. *Oeno One* 46(3): 177-183.
- Sabır A; Karaca U; Yazar K; Sabır F K; Yazıcı M A; Doğan O & Kara Z (2017). Vine growth and yield response of Alphonse Lavallée (*V. vinifera* L.) grapevines to plant growth promoting *Rhizobacteria* under alkaline condition in soilless culture. *Acta Sci. Pol. Hortorum Cultus* 16: 25-32.
- Sabır A; Sabır F & Jawshle A İ M (2020). Quality changes in grape berry as affected by the use of different colored shade nets proposed to alleviate the adverse effects of climate change. *Asian Journal of Agriculture and Food Sciences* 8(1): 1-5.
- Sabır A; Sabır F; Yazar K & Kara Z (2016). Investigation on development of some grapevine cultivars (*V. vinifera* L.) in soilless culture under controlled glasshouse condition *Current Trends in Technology and Science* 5(3): 622-626.

- Santamaria P; Campanile G; Parente A & Elia A (2003). Subirrigation vs drip-irrigation: effects on yield and quality of soilless grown cherry tomato. *The Journal of Horticultural Science and Biotechnology* 78(3): 290-296.
- Savvas D & Gruda N (2018). Application of soilless culture technologies in the modern greenhouse industry-A review. *Eur. J. Hortic. Sci* 83(5): 280-293.
- Savvas D; Gianquinto G; Tüzel Y & Gruda N (2013). Soilless culture. In good agricultural practices for greenhouse vegetable crops. *FAO Plant Production and Protection Paper 217* (Rome, Italy: FAO), p.303–354.
- Schröder F G & Lieth J H (2002). Irrigation control in hydroponics. *Hydroponic production of vegetables and ornamentals* 263-298.
- Schuch M W & Peil R M N (2011). Soilless cultivation systems: A new approach in fruit plants propagation in southern Brazil. In *International Symposium on Advanced Technologies and Management Towards Sustainable Greenhouse Ecosystems Greensys*, 952: 877-883.
- Sevgican A (2003). Örtü altı sebzeçiliği (Topraksız Tarım) Cilt-II, E.Ü. Ziraat Fakültesi Yayınları:526 İzmir, 168 s. [in Turkish].
- Sevindi C (2003). Economic significance and feasibility fields of the perlite beds in the city of Kars. *Journal of Social Sciences* 30: 169-186.
- Tagliavini M; Baldi E; Lucchi P; Antonelli M; Sorrenti G; Baruzzi G & Faedi W (2005). Dynamics of nutrients uptake by strawberry plants (*Fragaria*×*Ananassa* Dutch.) grown in soil and soilless culture. *European Journal of Agronomy* 23(1): 15-25.
- Tangolar S (2016). Örtüaltında bağcılık. *Bahçe Haber* 5 (1): 14-19.
- Tangolar S; Baştaş P C; Alkan Torun A & Tangolar S 2019a. Effects of substrate and crop load on yield and mineral nutrition of Early Sweet grape cultivar grown in soilless culture. *Erwerbs-Obstbau* 61(Suppl 1): S33–S40.
- Tangolar S; Gök Tangolar S; Alkan Torun A; Tarım G & Ada M (2017). Evaluation of table grape cultivation in soilless culture system (English abstract) *Turk J Agric Res* 4(2):163-170.
- Tangolar S; Kaya S; Torun A A; Tarım G; Ada M & Aydın O (2018). The effects of different growing media and root pruning applications on Trakya Ilkeren grape variety grown in soilless culture. *YYU J Agr Sci* 28 (Special Issue): 321-328.
- Tangolar S; Tangolar S G; Özdemir G; Bilir Ekbiç H & Rehber Dikkaya Y (2011). Bazı sofralık üzüm çeşitlerinin örtüaltında KKTC koşullarına adaptasyonu. VII. Bahçe Bitkileri Kongresi, 4-8 Ekim, 2011. Şanlıurfa.
- Tangolar S; Tangolar S; Ada M; Tarım G; Alkan Torun A & Ertargın E (2019)b. The effects of different nitrogen and potassium levels on yield and quality

of two early grape cultivars grown in different soilless media. *Acta Horti* 1242: 349-356.

Tangolar S; Tangolar S; Alkan Torun A; Tarım G; Ada M & Aydın O (2019) c. Effects of different nutrient solutions and growing media on yield and quality in grape growing in soilless culture (English abstract). *Mediterranean Agricultural Sciences* 32(Special issue): 127-133.

Tüzel Y; Gül A; Bahar Öztekin G; Engindeniz S; Boyacı F; Duyar H; Cebeci E; Durdu T (2020). Türkiye’de örtüaltı yetiştiriciliği ve yeni gelişmeler. *Türkiye Ziraat Mühendisliği IX. Teknik Kongresi 13-17 Ocak 2020 Ankara*, 725-750.

Tüzel Y; Gül A; Tüzel I H & Öztekin G B (2019). *Different soilless culture systems and their management. Journal of Agricultural, Food and Environmental Sciences JAFES* 73(3): 7-12.

Winsor G W & Schwarz, M (1990). Soilless culture for horticultural crop production. *FAO Plant Production and Protection Paper* 101. FAO, Rome, Italy. 188 p.

Zareei E; Zaare-Nahandi F; Hajilou J & Oustan S (2021). Eliciting effects of magnetized solution on physiological and biochemical characteristics and elemental uptake in hydroponically grown grape (*Vitis vinifera* L. cv. Thompson Seedless). *Plant Physiology and Biochemistry* 167: 586-595.

# CHAPTER 11

## RAISINS

Burçak İŞÇİ<sup>1</sup>

(Assoc. Prof. Dr.), EGE University, Faculty of Agriculture, Department of Horticulture, İzmir, Türkiye, e-mail: burcak.isci@ege.edu.tr

 0000-0002-6542-0271

### 1. Introduction

The vine is an ancient plant, grapes are consumed as fresh or dried and used in winemaking. Grape culture has its beginnings in Asia (Levadoux 1956; Zohary & Hopf 2000; McGovern 2003). The grape, which started to be seen in Anatolia about 8,000 years ago, has reached the present day by spreading to many regions of the Anatolian geography simultaneously or at different times. When the history of the vine in Anatolia is examined, grapes were used as an economical source of income, a therapeutic fruit, a wine for pleasure, or a product used for decoration in architecture and handicrafts (Winkler 1949; Anonymous 1972; Gürkan 2014).

Grapes are grown worldwide and they are eaten fresh and dried but mostly to make wine and used as other fermented beverages, on the other hand, unfermented juice. Raisins are extensively consumed worldwide in raw form or in the cooking, baking, and brewing industries because attractive flavor, texture, and nutritional value (vitamins A, B<sub>1</sub>, B<sub>2</sub>, Niacin and C). Türkiye, USA, China, Iran are among the important raisin producers in the world. Half of the world's total raisin production has been supplied by Türkiye and US for long years (Winkler 1949; Ağaoğlu 1999; Yılmaz *et al.* 2020; Ünal & Soltekin 2018).

### 2. Raisin Varieties

Raisins have been produced from different types of table grape cultivars, grapes must be the variety that yields raisins by certain standards when dried under natural or controlled conditions. Raisins have their unique flavor, color, and shape size (Winkler 1949; Ağaoğlu 1999; Kedage *et al.* 2007; Zemni *et al.* 2017; Jun *et al.* 2021). The term is limited to the production of a few varieties of raisins.

Only three varieties are grown commercially to produce raisins in countries with suitable growing conditions, which have dominated the world market for many years. ‘Thompson Seedless’ is important grape cultivars for the production of raisins. Its berry is elongated and oval. This grape has early ripening; the berries are easily separated from each other after drying. The other important cultivar is ‘Black Corinth’, which yields smaller raisins than the ‘Thompson Seedless’ cultivars, and it originated from Greece. ‘Thompson Seedless’ is preferred in the pastry industry because of its size, spherical shape, reddish to black color, thin skin, and seedless, because of its early ripening, quick-drying, and high production. ‘Muscat of Alexandria’ cultivar is the third important source for raisins production. This grape variety, which is muscat grape, is large, sweet, juicy, and contains few seeds. The main problem of this variety has seeds, and the seeds must be removed before drying (Christensen *et al.* 1995; Christensen & Peacock 2000; Thompson 2000; Ramming 2009).

***Thompson Seedless (Sultanina)*** – It has originated in Asia Minor. The grape called ‘Thompson Seedless’ in California is known as ‘Oval Kishmish’ in Türkiye, Iran, and other countries of Asia, and Near East or in the eastern Mediterranean regions and ‘Lady de Coverly’ in England (Winkler 1949; İltar & Altındışlı 2007; İşçi & Altındışlı 2015).

The clusters of ‘Thompson Seedless’ are large (typically ranging between 227 and 680 g), cluster is heavily shouldered; long cylindrical, and well filled (Figure 1).



Figure 1. Thompson Seedless. Photo, Anonymous (2021a)



‘Thompson Seedless’ berries are uniform and medium-sized (mean 1.8 g, typically ranging between 1.5 and 2.5 g). Their berries are ellipsoidal elongated; greenish-white to light golden; always seedless; firm and tender in texture; neutral in flavor; very sweet when fully ripened; moderately tender-skinned with light bloom, and fleshy pulp. The fruit ripens early in the season. Since the pedicels are somewhat weak, the berries shatter in transit if not the vines are girdled or the cluster are sprayed with a growth regulator. Leaves have three lobes, are medium green in color; large and glabrous on both sides, teeth are convex and mean-sized. Shoots are long; light green to yellowish-green; straight shoots with medium to long internodes, shoot tips light green and shiny. The vines are very vigorous and productive. The grapes dry easily into raisins of soft texture and excellent quality. Raisins are medium-sized (0.4 to 0.6 g); when dried naturally without dipping, its color is bluish-dark brown and has medium wrinkles (Winkler 1949; Christensen *et al.* 1995).

**Black Corinth (*Zante currant*)** – The ‘currant’ is oldest raisins, they have small berry size. It is another important group of seedless grape varieties produced in the world. Pliny, a Roman author, naturalist and natural philosopher of the early Roman Empire, mentioned of a tiny Greek grape with bunches exceedingly small, thin-skinned, juicy, and sweet. Trade of this raisin was recorded in the 11<sup>th</sup> century in some documents between the Greek producers and the Venetians. Raisins were reported as ‘Reysyns de Corauntz’ during the forty years from 1334 to 1377 in English markets. The name give from ‘Corinth’, the name of the port, this fruit reached western Europe from this port. There are different types of this grape variety, which is parthenocarpic, for example ‘Red (Rose) Corinth’ and ‘White Corinth’. These are distinguished from ‘Black Corinth’ by their red and white fruits. Synonyms include *Corinthe noir* in France, *Raisin de Corinthe* in Greece; and *Passolina* and *Passerina* (Italy).

The clusters of ‘Black Corinth (*Zante currant*)’ are small to medium in size (mean 182 g, ranging between 91 and 272 g); winged, uniformly cylindrical (Figure 2). ‘Black Corinth’ berries are very small (0.35 to 0.6 g); spherical to oblate. They are a reddish black color, mostly seedless, with an occasional seeded berry of medium size. The berry of ‘Black Corinth’ has very juice, neutral to spicy in flavor. Its skin is very thin and tender, pulp juicy and soft; flavor-rich, sweet, and fruity when fully ripe. Seed traces are almost undetectable in berries. Leaves are oblong; cordiform; medium-sized; five-lobed with deep. The petiole is medium-slender with pink tinge hoots. Shoots are medium internodes; medium green with very light pink coloration when herbaceous, light brown to brown when mature. Shoot tips are light green and white pubescence.



Figure 2. Black Corinth (Zante currant). Photo, Anonymous (2021a)

The vines are very vigorous and are productive if girdled or treated with a growth regulator. ‘Black Corinth’ ripens early and raisins are very small (0.09 to 0.14 g); bluish dark brown to black, and have medium to fine wrinkles (Winkler 1949; Christensen *et al.* 1995).



Figure 3. Muscat of Alexandria. Photo, Anonymous (2021a)

***Muscat of Alexandria*** – The Muscat of Alexandria, of North African origin, is a very ancient variety, made the raisins of Spain - the cluster Malagas and the stemmed Valencias or Muscatels. ‘Muscat of Alexandria’ is an important raisins variety in Australia. The clusters of ‘Muscat of Alexandria’ are medium-sized (mean 454 g, ranging between 114 and 999 g); shouldered, conical; loose, often straggly (Figure 3).

The berries of ‘Muscat of Alexandria’ are large (mean 5.5 g); obovoid, and dull green to light yellow with some ambering of exposed berries, they have flesh pulpy. When fully ripe in flavor, it has a strong muscat flavor and is normally seeded (seeds mean 30 mg dry weight).

Leaves are medium-sized; have a dark green color; petiolar sinus a narrow V often closed. The petiole is light pink in color and long, especially at the leaf junction. Shoot tips are woolly and light brown to brown color when matured. The vines are medium in vigor and very productive; they are head- or cordon-pruned. The ripening period of ‘Muscat of Alexandria’ is late midseason, and the grapes dry easily into large raisins of soft texture and excellent quality. Raisins are very large (mean 1.0 g); bluish dark brown; muscat flavor. They have medium to coarse wrinkles. The Muscat of Alexandria is adapted only to hot regions and is particularly sensitive to cold during its blooming season (Winkler 1949; Christensen *et al.* 1995).

***Sultana (Round Seedless)*** – This grape resembles the Thompson Seedless, but differs in having smaller, oblate, round berries - a few containing partly hardened seeds. The berries of ‘Seedless Sultana’ are round; light green to amber yellow, and have only a light bloom, which gives them a more transparent appearance than ‘Thompson Seedless’. The clusters are very large, compact, cylindrical, and heavily shouldered (Figure 4).



Figure 4. Seedless Sultana (Round Seedless). Photo, Anonymous (2021a)

Seed traces are often larger than those in ‘Thompson Seedless’. The ‘Sultana’ vine is vigorous and productive. It produces less meaty and more reddish colored raisins, and its sugar accumulation is inferior to that of ‘Thompson Seedless’. In general, as a raisins grape, it is lower ‘Thompson Seedless’ (Winkler 1949; Christensen *et al.* 1995; Vasilopoulou & Trichopoulou 2014).

**Monukka (Black Monukka)** – Although its true origin is unknown, the name of this grape is thought to come from the Persian word “Munaqqa” which means “raisins”. Its raisins are somewhat larger than those of Thompson Seedless. They have a mild, nutlike flavor; and are prone to becoming sticky in storage. In some years, the seeds of some berries develop sufficiently to be objectionable in the raisins.

The clusters of ‘Monukka (Black Monukka)’ are very large and very long; usually shouldered, conical irregular; loose to well filled, and mean 680 g, with a range of 226 to 1,135 g. The berries of the cluster are medium (mean 3 g); long oval to cylindrical; pink to reddish-black when fully ripe, thin-skinned, and with firm pulp; mostly seedless. Leaves are large; glabrous, which have deeply 5-lobed (Figure 5).



Figure 5. Monukka (Black Monukka). Photo, Anonymous (2021a)

The Black Monukka is a very vigorous grower and performs well with cordon pruning. The Monukka raisins are a darker color, and have larger seed traces compared to ‘Thompson Seedless’. It is mostly used in specialty markets such as health food stores for its unique qualities, including blackish color, tender skin, and has a characteristic-rich flavor (Winkler 1949; Christensen *et al.* 1995).

### 3. Raisins

Drying; it is the process of reducing the available water to prevent food from spoiling and increase its durability. Drying is an ancient and economical method to store and travel grapes for a long time without losing their nutritional value (Özer 2019). There are pieces of evidence of the use of raisins in archaeological finds in Bronze Age at Lachish in Israel. Raisins spread throughout the western world by Egyptians. The grape is unique, and it will naturally dry with no special pre-treatment. In the drying process, the water in the fresh grapes is evaporated, increasing the sugar content and decreasing the water activity. In this way, slowing down microbial, enzymatic, biochemical and chemical reactions. The shelf life of the product can be extended. Raisins are an important product with high economic value in worldwide. Raisins are a staple food, and ‘raisin’ originates from the French word ‘racemes’, which means ‘a cluster of grapes or berries’. In order for a grape variety to be qualified as a good drying raisin, the raisin obtained should have a soft texture, a distinct and pleasant taste, and less inclination to moisture during storage. ‘Thompson Seedless’ grape variety ranks first in raisin export in the world (Winkler 1949; Yağcı *et al.* 2005; Özdemir *et al.* 2009; Williamson & Carughi 2010; Zheng *et al.* 2012; Sharma & Adsule 2007; İşçi & Altındışlı 2016; Venkatram *et al.* 2017).

Four types of raisins are in demand in the world trade: sun-dried raisins which are ‘dark-skinned’; heat-dried raisins, which is ‘golden raisins’, small, dark raisins, initially from ‘Black Corinth’ grapes which is ‘Corinth raisins’ and large raisins which are ‘snack raisins’. Often the trade terms have different significance in different regions or with different kinds of raisins. For example, the crown grades are used in California to indicate only the size of Muscat raisins; when applied to the sultana and lexia raisins of Australia, they also indicate color and quality (Winkler 1949; Kedage *et al.* 2007; Zemni *et al.* 2017; Jun *et al.* 2021).

**Thompson Seedless** – ‘Thompson Seedless’ grapes are dried in the natural condition in California, Iran, and Turkestan. For this reason, without dipping treatment is not done for this production. They called ‘Thompson Seedless’ or ‘naturals’ to distinguish them from dipped raisins in California. Sometimes the trade knows them simply as ‘seedless’. Drying time is 15-20 days, these naturally dried grapes are dark-grayish black or grayish-brown—with rather tough-skinned, but meaty, and of characteristic oxidized flavor, they have dark-brown coloring. When properly dried, with they little tendency to cake in storage. They are often preferred to eating out of hand, because for cooking



their dark color, tough skins, and strong flavor may not always be desirable (Figure 6, a) (Winkler 1949; İşçi & Altındışli 2015).

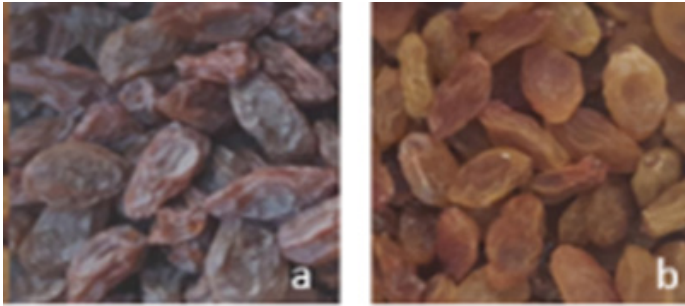


Figure 6. Raisins without dipping treatment (naturals) (a) and with dipped (b). Photo, Özer (2017)

**Sultana** – In Australia, South Africa, and other British countries, the name ‘Sultana’ is used to the light-colored, soft raisins. It is made from a variety called ‘Thompson Seedless’. The grapes are dipped into a solution contains potassium carbonate ( $K_2CO_3$ ), sodium hydroxide (NaOH), sodium bicarbonate ( $NaHCO_3$ ), ethyl oleate, and olive oil are the main compounds, being used as chemical pre-treatment. Apart from pre-treatment, the drying method greatly affects drying time and physico-chemical quality of raisin. The solution have some effects, most important is elimination of waxes and lipids. Chemicals such as potassium carbonate, sodium hydroxide, sodium bicarbonate, and ethyl oleate in solution, they can neutralize free fatty acids, and chemicals enhance water loss on the berry surface, and olive oil in solution gives softness to raisins (Esmaili *et al.* 2007; İşçi & Altındışli 2015).



Figure 7. Grapes dipped in solution dried in direct sunlight in Türkiye. Photo, Anonymous (2021b)

Grapes dipped in solution are be dried in direct sunlight as in Türkiye, mostly on soil, concrete and paper display areas (Figure 7).



Figure 8. Grapes dipped in solution dried on covered wire-shelved racks in South Africa, Photo, Anonymous (2020)

Greece, Iran, and Turkestan are similar to Türkiye. On the other hand, grapes dipped in solution are be dried on covered wire-shelved racks, as in Australia and South Africa (Figure 8). The raisins vary in color from greenish-yellow to medium brown, and drying time is 5-7 days (Figure 6, b). In dipping-dried grapes, the dipping solution helps speed up the grapes' drying and thus provides distinctive light yellow colored raisins, which does not allow browning reactions. As a result of the dipping process, the waxy layer on the grapes is washed, and the water holding feature of the grapes is lost and drying is accelerated. In addition, the activity of the ophenoloxidase enzyme found in the skin of the grape is inhibited and the natural yellow color of the grape is ensured. Raisins have both thin and light skinned colour. The surface is often slightly oily, and the flavor is characteristically nutlike. They are attractive in light-colored cakes and puddings. Raisins are very sweet and the skins are mostly fat; because of this feature, when used by bakers, they will slice along with the loaf instead of hanging onto the slicing knife and being dragged through (Winkler 1949; Altındışlı & İşçi 2005; Akdeniz 2011; İşçi *et al.* 2018).

The product from Australia and South Africa is always sold as 'sultana'. Similar raisins from Greece, Türkiye, Iran, and Turkestan are usually referred to in English-speaking countries as sultanas or sultana-type, but other names are applied in the regions of production. Occasionally, other raisins dried by similar processes are known as sultanas, and the term is also sometimes used loosely to include the light-colored golden-bleached and sulfur-bleached raisins of California. In the United States, the name 'Sultana' is given to a round-berried, nearly seedless grape variety-the Round Kishmish of Asia Minor-and to its natural sun-dried raisins. Although these raisins resemble the natural Thompson Seedless, they are usually considered inferior, less meaty and more acid, with occasional semihard seeds. They are very different from the light-colored, tender-textured sultana raisins of Australia and South Africa (Winkler 1949).



**Golden-bleached** – They are produced frequently by the golden-bleach process in California, they have light-colored. ‘Thompson Seedless’ grapes are remove clusters of damaged, underripe, or overripe fruit. Grapes are washed in cold water to produce slight cracking of the skins. After these procedures, they are dehydrated at temperatures of 140<sup>0</sup> to 160<sup>0</sup> F in burning sulfur house.



Figure 9. Golden bleached raisins. Photo, Anonymous (2020a)

The raisins are brilliant lemon yellow, the skin of these raisins moderately tender and sometimes a little sticky (Figure 9). For some persons, their sulfür dioxide taste is objectionable for eating out of hand; this taste disappears entirely when they are baked or otherwise cooked. It is important to use sulfur dioxide in the drying process, as preserving the yellow color is also necessary during the storage. In international trade the golden-bleached raisins of California compete successfully with the Australian-type sultanas from other regions.

**China Golden Bleached** – China is the only major producer of green raisins; China is followed by India and Afghanistan, respectively. The favorable climatic conditions encourage the production of green raisins in China, India and Afghanistan.



Figure 10. A house made of mud cabin called “kishmish khana” for drying grapes, wire-shelved racks. Photo, Özer (2017)

Producers dry their grapes by blocking the sunlight inside the traditional mud cabin houses they have built in the form of perforated walls. Thanks to the holes in the walls, airflow is provided and the grapes are not exposed to sunlight while drying (Figure 10).

Grapes dried in dry air without exposure to sunlight, it preserves its chlorophyll and remains green (Figure 11). Grapes protected from sunlight in specially constructed drying rooms can be dried in green color thanks to hot and dry air (Meng *et al.* 2011). However, the drying process in the shade is a method that takes a long time, and the long drying time causes the colors of the grapes to turn brown. To prevent browning and increase the green drying rate, applications are made to shorten the drying time (Dong *et al.* 2011; Shen 2013).



Figure 11. China Golden Bleached raisins. Photo, Özer (2017)

***Sulfur-bleached*** – Process is the same way as the golden-bleached until the start of drying. The grapes are exposed on trays to direct sunlight. According to the length of exposure to sunlight, the resulting raisins are waxy and cream-colored to faintly reddish yellow (Winkler 1949).

***Soda-oil-dipped*** – Thompson Seedless grapes for the so-called soda-oil-dipped raisins are dipped in a sodium carbonate solution having a thin film of olive oil floating on the surface. It is made exactly the same way as described for the Golden Bleach product, except it is not bleached with sulfur. The grapes with solution are dried on trays in direct sunlight. The raisins are medium to dark brown in color, fairly tender, and slightly oily but not sticky (Winkler 1949).

***Black Corinth*** – For centuries, Zante currant raisins have been made in Greece, where the variety probably originated and where much of the world's supply is produced. 'Black Corinth' ripens early. Grapes are all dried in direct sunlight or shade without pre-treatment. After drying, raisins have a soft texture with a pleasing tart taste and very small raisins. They are called currants or Zante currants in all English-speaking countries. Greece and Australia are the principal

producers, and small quantities are produced in California and South Africa. The raisins are dark and very small, with a tart taste and characteristic mild flavor (Figure 12). They are highly esteemed for cooking and baking, because ‘Black Corinth’ raisins are small size and tender skin. They use mostly for cooking and baking (Winkler 1949).



Figure 12. Black Corinth raisins. Photo, Anonymous (2021c)

**Muscat** – Raisins are produced from ‘Muscat of Alexandria’ grapes, principally in California and the province of Málaga in Spain and they have natural sun-dried. If stemmed and not seeded, The California raisins are called ‘loose Muscats’, and if the seeds have been removed, it called ‘seeded Muscats’. Unstemmed raisins, called ‘layers’ or ‘clusters’, were also formerly produced in California.



Figure 13. Málaga raisins. Photo, Anonymous (2021d)

The raisins from the Spanish province of Málaga are carefully dried on the clusters and packed without stemming and are known in world markets as Malagas (Figure 13). These raisins are very large; grayish brown, with the bloom mostly intact, and very meaty, with strong Muscat-raisin flavor and rather tough skins (Winkler 1949).

**Valencias, lexias** – Large quantities of Muscats are dipped before drying in Spain and Australia. Grapes dried under direct sunlight. During the drying process, the grapes are covered with sheeting in order not to be damaged during rain and at

night. When dried, they are stemmed and sold as ‘Valencias’. If production is in Australia, it is rack-dried as the sultanas and is called ‘lexia’ a term sometimes also applied to the Valencia raisins of Spain (Winkler 1949).

### 3. Drying Methods

The drying of grapes varies in different parts of the world, particularly they are affected by these cultivation conditions. Traditionally, raisins have been produced from fully ripened grapes; the drying process, which has been done with the effect of sun and wind for centuries, gained importance as a technology branch only in the middle of the twentieth century. The aim of drying processes is to produce a high quality dried product with minimum cost.

Sun-drying of raisins requires a long time, therefore to increase the drying rate is used chemical pre-treatments. This method has several disadvantages, for example insect infections, dust, microbial and color deterioration. Apart from that, the removal of small stones, soil, leaves, dust, etc. collected for the period of raisin gathering is an extra job and vexing problem during the raisin cleaning phase. Drying of the raisin grapes begins after harvest in late August and lasts until approximately the second week in October. The critical drying period is September because rains can damage grapes. When rain threatens, polyethylene are covered on the grapes as a protective measure, but a huge amount of grapes and the large area with lots of grapes spread make such protection a costly enterprise. Increasing efforts have been made to modify and develop traditional grape drying procedures. In recent years, new methods of indirect solar drying have been developed. Mechanical drying is safe, rapid, and controllable. The industrial application of microwave heating for the preparation of dried grapes has been reported in recent years in the literature. The microwave vacuum dryer system has originally introduced for California seedless grapes (puffy dried grapes) (Foshanji *et al.* 2018).

Moisture content of grape during drying is reduced from approximately 75% to below 15%. The yield and quality of raisins be related to the Brix of grape berry taken for drying purpose, yielding approximately 1 kg of raisins out of 4 kg of grapes. Raisins’ color, flavor, and texture differences result from the method of drying. The final raisins’ color depends on the grape cultivar and the drying method. The drying process keeps diversity of the product on the market and responds to consumers’ demands. When the drying process is finished, raisins are evaluated in terms of appearance, texture, cleanliness, flavour, and nutritive value. Tenderness of skin, a desirable characteristic in raisins for

cooking or baking, is largely a function of the drying method and the grape variety. Muscat of Alexandria has a somewhat tough skin, Thompson Seedless is medium in this respect, and Black Corinth is rather tender; Australian-type sultana raisins are the tenderest. Golden-bleached, sulfur-bleached, and soda-dipped Thompson Seedless and soda-dipped Muscats (Valencias and lexias) are moderately tender. Large size (weight) is always desirable in dessert raisins. For cooking and baking, bakers prefer small sizes; size is less important than color and texture (Thompson 2000; Petrucci 2001; Wang *et al.* 2020; Sharma *et al.* 2013).

**Sun-dried** – Sun-dried grapes are produced by placing grape clusters on 80 cm by 90 cm papers or polyethylene trays or materials that are either short (2 m to 6 m) or long (greater than 6 m). The trays or materials are laid out on concrete floors next to the vineyards or on leveled ground between the vine rows for 2 to 3, sometimes four weeks depending on weather conditions (Figure 14).



Figure 14. Sun-dried grapes in vineyards in Türkiye (a), and California (b). Photo a, Anonymous (2021e), Photo b, Anonymous (2018)

In general, 18-20 kg of fresh grapes can be laid on an mean of 1 m<sup>2</sup> on leveled ground. Because more grapes can be laid per unit area, it uses wire-shelved racks installed near the vineyards while the grapes are dried under the sun.



Figure 15. Sun-dried grapes on wire-shelved racks in Manisa, Türkiye. Photo, Anonymous (2021f)



It is very important to have sufficient sunbathing in the completely portable wire-shelved racks system; it is calculated that an mean of 6 kg of fresh grapes will be laid on one meter of wire length on wire-shelved racks (Figure 15). When the process is finished (moisture content is approximately 15%), the raisins are transported to a processing plant (Christensen & Peacock 2000).

**Dried-on-vine** – When the fruit is between 20-23° Brix, a crew of workers come into the field and use hand shears or pneumatic shears cut last year’s fruit cane to facilitate even drying and efficient removal of the finished product. Generally, the dried-on-vine method of raisins production often uses mechanical harvesters. The cluster uses maximal sun exposure in this method.

The grapes are left on the vine in the vineyard. The berries lose their water content during the over-ripening process and progressively shrivel. Before harvesting, 50% of the fruit near the leaf area is removed by hand pruning the canes in this method. During the cane cutting, clusters are dipped in a solution (0.5% ethyl oleate and 0.6% potassium carbonate ( $K_2CO_3$ )), in this way to increase the drying rate and to achieve the desired light-gold fruit color in the ‘Thompson Seedless’ raisins. The dried-on-vine method reduces the risk of rain damage. Dried-on-vine (DOV) raisins take 30 to 40 days to complete the drying process at temperatures closer to ambient (Figure 16) (Dincer 1996; Uhlig *et al.* 1996; Peacock & Swanson 2005).



Figure 16. The dried-on-vine method of Thompson Seedless (a), and Black Corinth (b). Photo, Vasquez & Fidelibus (2021)

**Shade-dried** – It is the process of drying the grape with the help of heat and airflow by preventing its contact with sunlight. Countries such as China, India, and Afghanistan can dry their grapes without the need for sunlight, thanks to their high air temperature and low humidity. In Afghanistan, it is traditionally done in mud cabin called “kishmish khana” in the shade and under the airflow (Figure 17).

Grapes protected from sunlight in specially built drying houses are dried in green color thanks to the hot and dry air. This drying has some advantages; in

this way, they are not affected by the precipitation that may occur during drying, insect, dust, and foreign objects are prevented from contaminating the grapes, and there is much more product per unit area. However, since it is deprived of direct sunlight, the drying time is prolonged.



Figure 17. A simple 'kishmish khana' and hanging grapes. Photo, Özer (2017)

**ot-air drying** – Grapes are hand-harvested and transported to a drying facility with a concrete tunnel with a fan and propane burner mounted above the drying chamber to provide hot air flow between 65°C and 70°C at the hot-air drying method. To facilitate water loss from the surface, grapes are dipped for 8 to 15 seconds in a hot solution that contains 0.2%-0.5% sodium hydroxide at 82°C, and then are rinsed with cold water. The grapes are then spread on drying trays and treated for 5 to 8 hours with SO<sub>2</sub> at a concentration of 2 kg to 4 kg per ton of grapes. The hot-air drying method has the advantage of ensuring a uniform supply of golden raisins, but the relatively high cost limits its use. Microwave heating can be used in grape drying, however, undesirable partial puffing may occur in the dried structure when grapes are dried at high moisture contents, but this technology can still be a good alternative to traditional techniques. With the increasing energy costs, the use of solar energy in the agricultural field, especially in drying processes, has begun to be investigated (Figure 18) (Aguilera *et al.* 1987; Thompson 2000; Dev *et al.* 2008; İşçi & Altındışli 2016).



Figure 18. Solar energy drying systems. Photo, İşçi & Altındışli (2016)



Raisins are not offered for consumption as soon as they come from the vineyard or drying yard. They are first cleaned, stemmed, and sorted. This work is ordinarily done in a packing house. The success of the packing process and the whole raisin industry depends on the vinegrower's care and skill all along the way, from growing the grapes until he delivers the raisins to the packing house. Raisins are be stored at 0-4 °C in 50-60% humidity for one year. Grapes should contain a maximum of 15-20% moisture, while grapes that will be stored for longer periods should have a lower moisture content (Cemeroğlu & Özkan, 2004b).

## References

- Aguilera JM; Oppermann K & Sanchez F (1987). Kinetics of Browning of Sultana Grapes. *J. Food Sci.* 52: 991-993
- Ağaoğlu S (1999). *Scientific and Applied Viticulture (Volume I, Vine Biology)*. Rekmay Ltd., Ankara 1999 (Turkish).
- Akdeniz B (2011). Traditional Drying Method of Sultani Seedless Grape Variety. *Electronic Journal of Food Technologies* 6(1):13-22
- Altındaşlı A & İşçi B (2005). Applicability of a New Analysis Method on the Detection of Oil Quantity in Dipping Solution for Process of the Raisin. *The Journal of Ege University Faculty of Agricultural* 42(3): 13-19
- Altındaşlı A; Altındaşlı Ö; Çeliker NM; Özsemerci F & Caner ÖK (2012). *Sultani Seedless Grape Cultivation Handbook for Drying*. Egesan Basım Ambalaj ve Sürekli Formları San. Ve Tic. Ltd. Şti., İZMİR, 105s (Turkish).
- Anonymous (1972). *Seedless Raisin Seminar*. İzmir Ticaret Borsası. 450 pages (Turkish).
- Anonymous (2018). <https://americanvineyardmagazine.com/2018-california-raisin-grape-mechanical-harvest-report>. (Accessed 10 November 2021).
- Anonymous (2020). <https://www.armersweekly.co.za/agri-news/south-africa/export-opportunities-for-south-african-raisins-to-the-uk>. (Accessed 07 November 2021).
- Anonymous (2020a). <https://www.britannica.com/topic/raisin>. (Accessed 07 November 2021).
- Anonymous (2021a). *Division of Agriculture and Natural Resources, University of California*. (Accessed 25 November 2021).
- Anonymous (2021b). <https://www.fruitsoffTürkiye.com/products/dried-fruits/sultana-raisins>. (Accessed 5 November 2021).
- Anonymous (2021c). <https://herballove.shop/products/authentic-greek-currants-from-corinth-zante-currants-corinthian-raisins>. (Accessed 5 November 2021).

- Anonymous (2021d). <https://www.antequera.co.uk/malaga-raisins/>. (Accessed 15 November 2021).
- Anonymous (2021e). <https://www.fruitsofTürkiye.com/turkish-sultana-raisins-market-update/>. (Accessed 7 November 2021).
- Anonymous (2021f). <https://manisa.tarimorman.gov.tr/Sayfalar/AlbumDetay.aspx?OgeId=2852>. (Accessed 8 November 2021).
- Ateş F; Ünal A; Takma Ç & Altındaşlı A (2016). Effects of Different Level of Leaf Removal Applications on Mineral Substance of Raisins in Organic Sultani Çekirdeksiz Grape Growing. *BIO Web of Conferences*, 7, 5p.
- Christensen PL; Bianchi ML; Lynn CD; Kasimatis AN & Miller MW (1995). Harvest Date on Thompson Seedless Grapes and Raisins. I. Fruit Composition, Characteristics, and Yield. *Am. J. Enol. Vitic.* 46: 10-16
- Christensen PL & Peacock WL (2000). The Raisin Drying Process. In: Raisin production manual. pp. 207 – 216. P. Christensen (ed.), University of California, Agriculture and Natural Resources, Publication 3393, Oakland, CA, USA.
- Cemeroğlu B & Özkan M (2004). Drying Technology. Fruit and Vegetable Processing Technology, Volume II, B. Cemeroğlu (ed.) pp 479-618, Başkent Kılış Matbaacılık, Ankara.
- Dev SE; Padmini T; Adedeji A; Gariépy Y & Raghavan GS (2008). A Comparative Study on The Effect of Chemical, Microwave, and Pulsed Electric Pretreatments on Convective Drying and Quality of Raisins. *Dry. Technol.* 26: 1238-1243
- Dincer I (1996). Sun Drying of “Sultana” Grapes’. *Dry. Technol.* 14: 1827-1838
- Dong Y; Lu JD; Yang L; Zhang Z & Xue Y (2011). Research Progress of Raising Solar Raised Heat Pump. *National Rural Clean Energy and Low Carbon Technology Sumposium Proceeding*.
- Esmaili M; Sotudeh-Gharebagh R; Cronin K; Mousavi MAE & Rezazadeh G (2007). Grape Drying: A Review. *Food Reviews International* 23: 257–280
- Espíndola RS; Gutierrez A & Suero E (2019). Features of Raisins Grape Quality According to The Drying Process Method Used. *IJRDO - Journal of Agriculture and Research* 5(2): 1-7
- Foshanji AS; Krishna HC; Vasudeva KR; Ramegowda GK; Shankarappa TH; Bhuvaneshwar S & Sahel NA (2018). Effects of pre-treatments and drying methods on nutritional and sensory quality of raisin. *Journal of Pharmacognosy and Phytochemistry* 7(4): 3079-3083

- Gürkan H (2014). The Importance Throughout the History of *Vitis Vinifera* L. and Today's Use. Erciyes University, Faculty of Pharmacy. Master's thesis, 106 pages (Turkish).
- İlter E & Altındışlı A (2007). "Turkish Sultans", Seedless Raisins, Dried Figs, Dried Apricots. Aegean Dried Fruits and Products Exporters' Association, İzmir, 139 (Turkish).
- İşçi B & Altındışlı A (2015). Drying of *Vitis Vinifera* L. Cv. "Sultanina" in Tunnel Solar Drier. BIO Web of Conferences, 5. DOI: 10.1051/bioconf/20150501016.
- İşçi B & Altındışlı A (2016). Drying of *Vitis vinifera* L. cv. "Sultanina" in Polythene Tunnel Solar Drier and Traditional Method. The Journal of Ege University Faculty of Agricultural 53(4): 469-479 (Turkish).
- İşçi B; Altındışlı A & Şafak M (2018). Quality Criteria of Seedless Raisin Drying With Solar Energy System. Bahçe 47(1): 121–129
- Jun Wang; Mujumdar AS; Wang H; Fang XM; Xiao HW & Raghavan V (2021). Effect of Drying Method and Cultivar on Sensory Attributes, Textural Profiles, and Volatile Characteristics of Grape Raisins. Drying Technology An International Journal 39: 4: 495–506. DOI: 10.1080/07373937.2019.1709199
- Kedage VV; Tilak JC; Dixit GB; Devasagayam TP & Mhatre M (2007). A Study of Antioxidant Properties of Some Varieties of Grapes (*Vitis vinifera* L.). Crit. Rev. Food Sci. 47: 175-185. DOI: 10.1080/10408390600634598
- Levadoux L (1956). Les Populations Sauvages et Cultivees de *Vitis vinifera* L. Ann. Amelior. Plantes. 6: 59-118
- McGovern P (2003). Ancient Wine: The Search for The Origins of Viticulture. Princeton University Press, Princeton
- Meng J; Fang Y; Zhang A; Chen S; Xu T; Ren Z; Han G; Liu J; Li H; Zhang Z & Wang H (2011). Phenolic Content and Antioxidant Capacity of Chinese Raisins Produced in Xinjiang Province, Food Research International 44(9): 2830-2836
- Özdemir Y; Erdoğan S & Kurultay Ş (2009). Raisin Production and Changes in Grapes during Drying. Türkiye 7<sup>th</sup> Viticulture and Technologies Symposium (Turkish).
- Özer G (2019). Research of Green Raisin Production of Techniques. Ege University, Faculty of Agriculture, Horticulture Department. Master's thesis, 93 pages
- Peacock WL & Swanson FH (2005). The Future of California Raisins is Drying on the Vine. California Agriculture 59(2): 70-74

- Petrucchi V (2001). Raisin Grape Varieties. A treatise on Raisin Production, Processing and Marketing. Clovis (Calif): Malcom Media Press.
- Ramming DW (2009). Water Loss from Fresh Berries of Raisin Cultivars under Controlled Drying Conditions. *Am. J. Enol. Vitic.* 60: 208-214
- Sharma AK; Satisha J & Somkuwar RG (2013). Raisin Quality: The Deciding Factors. National Research Centre for Grapes, Pune (India) (Accessed 25 November 2021).
- Sharma AK & Adsule PG (2007). Raisin Production in India. Post Harvest Technolog. DOI: 10.13140/2.1.3483.8407.
- Shen W (2013). Research Progress of Natural Green Raisin Drying Equipment. Xinjiang Academy of Agricultural Sciences.
- Thompson J (2000). Tunnel dehydration. In: Raisin Production Manual. pp. 224 – 227. P. Christensen (ed.), University of California, Agriculture and Natural Resources, Publication 3393 Oakland, CA, USA.
- Uhlig BA; Walker RR & Storey R (1996). Mode of Action of The Drying Emulsion Used in Dried Vine Fruit Production: I. The Effect Of Inorganic Ions and Fatty Acid Esters. *Austral. J. Grape Wine Res.* 2: 84- 90
- Ünal A & Soltekin O (2018). Raisins: World's Production and Trade. *Bahçe* (47): 1-9 (Turkish).
- Vasilopoulou E & Trichopoulou A (2014). Greek raisins: A traditional nutritious delicacy. *Journal of Berry Research* 4: 117–125. DOI:10.3233/JBR-140074.
- Vasquez S & Fidelibus M (2021). Dried-on-Vine (DOV) Raisin Cultivars. UC Cooperative Extension. (Accessed 25 November 2021).
- Venkatram A; Padmavathamma AS; Rao BS; Sankar AS; Manorama K & Vijaya D (2017). Effect of Antioxidants on Drying, Yield, Hunter Color L\*, a\*, b\* and Moisture Content of Dried-On-Vine Raisins Prepared from Seedless Varieties of Grape (*Vitis vinifera* L.). *Int. J. Pure App. Biosci.* 5(4): 1127-1134. DOI: <http://dx.doi.org/10.18782/2320-7051.5701>.
- Wang D; Javed HF; Shi Y; Naz S; Ali S & Duan CQ (2020). Impact of Drying Method on the Evaluation of Fatty Acids and Their Derived Volatile Compounds in ‘Thompson Seedless’ Raisins. *Molecules* 25: 608; DOI:10.3390/molecules25030608.
- Williamson G & Carughi A (2010). Polyphenol Content and Health Benefits of Raisins. *Nutrition Research* 30: 511-519. DOI:10.1016/j.nutres.2010.07.005
- Winkler AJ (1949). Grapes and Wine. *Econ. Bot.* 3: 46-70
- Yağcı A; Altındaşlı A; Kader S; İlter E & Cura M (2005). Researches on the Change of Nutrients from Seedless Grape Grown in the Aegean Region from Harvest to Post-drying. 6<sup>th</sup> Türkiye Viticulture Symposium (Turkish).

- Yılmaz F; Shidfar M; Hazrati N; Kazan K; Yüksel Özmen C; Uysal T; Özer C; Yaşasın AS; Söylemezoğlu G; Boz Y; Çelik H & Ergül A (2020). Genetic Analysis of Central Anatolian Grapevine (*Vitis vinifera* L.) Germplasm by Simple Sequence Repeats. *Tree Genetics & Genomes* 16: 55. DOI: 10.1007/s11295-020-01429-z.
- Zemni H; Sghaier A; Khiari R; Chebil S; İsmail HB; Nefzaoui R; Hamdi Z & Lasram S (2017). Physicochemical, Phytochemical and Mycological Characteristics of Italia Muscat Raisins Obtained Using Different Pre-Treatments and Drying Techniques. *Food Bioprocess Technol.* 10: 479-490. DOI: 10.1007/s11947-016-1837-4.
- Zheng Y (2012). Study on the Key Technology of Green Raisin Processing, Northwest A&F Universty.
- Zohary D & Hopf M (2000). Domestication of Plants in the Old World. Oxford University Press, London.



## CHAPTER 12

# COMPOSITION OF RAISIN, ITS IMPORTANCE FOR HEALTH AND USAGE OF GRAPE IN FOLK MEDICINE

Adnan DOGAN<sup>1✉</sup> & Cuneyt UYAK<sup>2</sup> & Haydar KURT<sup>3</sup>

<sup>1</sup>(Assist. Prof. Dr.), Van Yuzuncu Yil University, Faculty of Agriculture, Department of Horticulture, Van, Türkiye,  
e-mail: adnandogan@yyu.edu.tr

 0000-0002-8623-0629

<sup>2</sup>(Assist. Prof. Dr.), Van Yuzuncu Yil University, Faculty of Agriculture, Department of Horticulture, Van, Türkiye,  
e-mail: cuneytuyak@yyu.edu.tr

 0000-0002-6101-6845

<sup>3</sup>(Assist. Prof. Dr.), Van Yuzuncu Yil University, Faculty of Agriculture, Department of Horticulture, Van, Türkiye,  
e-mail: haydarkurt@yyu.edu.tr

 0000-0002-4637-1996

### 1. Introduction

**G**rape is one of the most delicious and refreshing fruits in the world. Grape is a fruit mentioned in all scriptures and teachings. Grape throughout history; it has been said in many places from mythologies, folk tales, literature to culture and art. This is because the grape is accepted by societies. Raisins have been a few foods that all mystical clerics (saints, monks) keep with them on their seclusion journey to reach God or nirvana. In the sense that raisins are easy to store, it can be foreseen that they were collected and consumed long before humans settled down. During the historical process, raisins have always been found in their pantries as food they can consume in winter in societies



acquainted with grapes. The value not given to any other fruit has been given to grape, wine and grape products in the historical process.

The grape and facts about grapes have taken an important place in every aspect of life from the past to the present. Throughout history, people have embroidered symbols related to grapes on their belongings and architectural artifacts both in their religious places and daily lives. This is an indication of the importance they give to grapes. The most significant proof of this is that these symbols are seen in historical monuments from the past to the present and still emerge as a result of archaeological excavations. Grape is a miraculous fruit and it is very precious. Traces of the past, which are indicative of this importance, are seen in Figure 1. Grape is an important food that we should include in our lives when looking at health benefits and research.



Konya, Ereğli Aydıncıkent (Dvriz) - Pre-Hittites (1200-742 BC), Dvriz Rock Relief belongin King Warpalavas (Sağlam & Sağlam, 2018).



Vine and grape figures were also used frequently in Anatolian civilizations on fountain heads and tombstones (Mutlu, 1997).



It is thought that the source of the Dionysos belief in Greek civilization is the god holding a bunch of grapes in her hand on the Dvriz relief (Sağlam & Sağlam, 2018).



The wine jug and pedestal wine glass made of solid gold belonging to the Hittites in 3000 BC, exhibited in the Museum of Anatolian Civilizations, is the oldest wine container found (Deliorman et al., 2011).

Figure 1. The best expression of the importance of grapes in history.

Raisins are mostly obtained from different varieties of *Vitis vinifera* L. The type of raisins depends on the variety, color, seed state and size of the grape. The most common raisins consumed globally are those usually obtained from Thompson seedless grapes (Olmo-Cunillera *et al.* 2020). Raisins, which are helpful to human health, are an important source for many bioactive compounds, including mineral substances, vitamins, phenolic compounds, anthocyanins and organic acids (Shahidi & Tan 2013).

## 2. Health Benefits of Raisins

Most of the foods consumed by modern people are processed foods originating from industry (packaged products) which have been the primary source of diseases. People have invited many diseases such as cardiovascular diseases, obesity, diabetes, cholesterol, neurological degeneration, alzheimer's, cancer, digestive system disorders, lack of mineral substances and vitamins, bone loss, and degeneration of joints due to malnutrition. Moving away from naturalness has increased the deterioration in human health. Humanity unconsciously consumed foods that appealed to taste and pleasure. Now, we realize the evil we've done to ourselves. We began to look for the remedy by moving towards nature and the nature that we had ruined. Until recent years, many traditional products with the knowledge of thousands of years have been noticed again. Intensive scientific studies are carried out on these foods. There is a significant acceleration in the trend towards alternative medicine and traditional foods in health and treatment in today's modern world.

Carbohydrates, fats, and proteins called macronutrients, 13 vitamins, and 17 minerals necessary for our health are essential for nutrition. Apart from these, the importance of plant-derived natural compounds called phytochemicals has been understood. Unlike vitamins and minerals, phytochemical (phenolic compounds and natural color substances) substances are not considered nutrients. Phytochemicals, which are secondary compounds, contribute to a long and healthy life by preventing and controlling non-communicable diseases, especially in populations with genetic predisposition (Abuajah *et al.* 2015; Papadaki *et al.* 2021).

Today, phytochemicals are understood to have antioxidant properties that render the molecules that attack the cells in our body harmless, called free radicals. Phytochemicals are considered as powerful potential agents to protect against diseases from aging to cancer. Epidemiological studies show that phytochemical substances found in plants and fruits play essential roles in treating many diseases. Humanity, whose knowledge level is increasing,

continues their orientation towards natural, organic foods for a healthy life. The decrease in food security has increased the orientation towards natural foods. This orientation has led the scientific world to research in this direction (Abuajah *et al.* 2015; Papadaki *et al.* 2021).

Regardless of genetic factors, the incidence of neurodegenerative diseases in the aging population is affected by nutrition. Many studies have focused on illuminating the mechanical effect of polyphenols with neuroprotective potential through the consumption of micronutrients and secondary plant metabolites (Schaffer & Halliwell 2012; Sreenivasan & Watson 2015). Metabolic syndrome is a combination of at least three factors that occur together. Obesity, cardiovascular disorders, and type 2 diabetes lead to this syndrome risk. Preventing and managing metabolic syndrome can be achieved by changes in eating habits and lifestyle. Regulating diets with functional foods and bioactive compounds can help prevent metabolic syndrome by preventing oxidative stress (Mohamed 2014; Fulgoni *et al.* 2017; Papadaki *et al.* 2021).

Grape contains nutritional and protective elements such as vitamins, minerals, carbohydrates, edible fibers, and phytochemicals. Polyphenols are the most important phytochemicals in grapes. They are involved in many biological activities in the human body and have health-protective effects. Phenolic compounds contain anthocyanins, flavanols, stilbenes (resveratrol), and phenolic acids. Anthocyanins are the primary pigments in the skin of grapes. Flavonoids are abundant in the seeds and stems of grapes and contain polymers of (+) catechin, (-) epicatechin, and procyanidins. While anthocyanins are the primary polyphenols in red grapes, flavan-3-ol are dominant in white grapes (Xia *et al.* 2010).

Grapes are food that helps bones and teeth to grow with the mineral substances it contains and gives the blood a suitable pH. The aromatic substances and fruit acids in grapes have an appetizing property. These substances play a role in facilitating digestion by making the glands work better. It is also significant for human health and nutrition with vitamins A, B1, B2, and C in its structure (Şamil *et al.* 2005).

Many studies have been carried out on the health effects of rutin and quercetin, which are flavonoids. Flavonoids have been used in folk medicine to treat diseases such as inflammation, allergies, headaches, periodontitis, virus and fungal infections, stomach or duodenal ulcers, and even cancer. Flavonoids are powerful antioxidants found in plants and contribute to human nutrition. Flavonoids are reported to cause a decrease in deaths from heart disease (Palomino *et al.* 2000).

Many researchers have reported that catechin derivatives ((-) epicatechin gallate) show strong biological activity and prevent or stop cell deaths. Yang *et al.* (2007) have reported that (-) epicatechin and other catechin derivatives inhibited the development of tumors.

As the perception of consumers changes towards healthier and more sustainable nutrition models, there is an increasing demand for functional foods. Functional foods contain various compounds that positively affect health and reduce the risk of disease (Ashwell 2004; Küster-Boluda & Vidal-Capilla 2017). Products that are reduced in sugar and fat and enriched with fiber, probiotics and vitamins are defined as functional foods (Papadaki *et al.* 2021).

In recent years, the concept of superfoods, which is included in functional food class, has been emphasized. The interest in functional foods and superfoods has increased due to their health benefits (Salantă *et al.* 2020; Papadaki *et al.* 2021). Various scientific records define superfoods as natural or minimally processed foods with high nutritional value, healthy and highly bioactive components (Salantă *et al.* 2020; Proestos 2018). Polyunsaturated fatty acids, vitamins, minerals, probiotics, antioxidants, and polysaccharides are biomolecules in superfoods. These active compounds help reduce the risk of cardiovascular diseases, cancer, and type 2 diabetes, prevent degenerative diseases, lower cholesterol, and promote immunity (Abuajah *et al.* 2015; Papadaki *et al.* 2021).

With the modern lifestyle, the orientation to traditional foods that have been ignored for years and efforts to rediscover them have increased (Papadaki *et al.* 2021). Therefore, orientation to traditional foods such as blueberries, acai, goji, raisin, dried fig, and dried apricot, known as superfruits, have increased (Trichopoulou *et al.* 2006). Realizing that fresh and dried fruits are sources of functional compounds has also led to increased demand for new and functional foods.

Anatolia is a geography where many civilizations and cultures coexist. All civilizations that lived in this geography attributed sanctity to the grape. Grape is processed in many different traditional foods in this geography. When grape products are mentioned in this geography, first the grape itself as food then products derived from grapes such as 'pekmez' (molasses), 'sucuk', 'pestil', 'köfter', must, grape juice, vinegar, and wine comes. Products such as 'pekmez' (molasses), 'pestil', 'sucuk', 'köfter' and 'bastık' (Figure 2) are traditional products with no exact equivalent in other countries and Europe and are superfoods (Er 2006).





Figure 2. Miraculous fruit grape and products derived from the grape.

The first cultures directly encountered with molasses are Greek, Roman, and Byzantine. In ancient Greece, molasses was called ‘*epsima/έψημα*’ and today the same product is called ‘*petimezi*’ in Greece, Cyprus and Crete (Uhri, 2017).

Compared to fresh grapes, raisins and ‘*pekmez*’ (molasses) are richer in higher calorie, iron and calcium minerals due to their lower water content (Göktaş, 2008). The nutritional and chemical content values of raisins (100 g) are shown in Table 1. Today, foods with high phytochemical content are given importance. Vegetable foods such as phenols and polyphenols are considered as antioxidants (Di Lorenzo *et al.* 2016).

Table 1. Content values of raisins (100 g) (USDA 2021).

Nutrient	Golden Raisins	Dark Raisins	Nutrient	Golden Raisins	Dark Raisins
<b>Proximities</b>			<b>Vitamins</b>		
Water (g)	14.90	15.46	Riboflavin (mg)	0.191	0.125
Energy kcal	301	299	Niacin (mg)	1.142	0.766
Protein (g)	3.28	3.30	Vitamin B-6 (mg)	0.323	0.174
Total lipid (g)	0.20	0.25	Folate (DFE) <sup>1</sup> (μg)	3	5
Carbohydrate (by difference) (g)	80.02	79.32	Vitamin B-12 (μg)	0	0
Fiber (total dietary) (g)	3.30	4.50	Vitamin A (RAE) <sup>2</sup> (μg)	0	0
Sugars (total) (g)	65.70	65.18	Vitamin A (IU) <sup>3</sup> (μg)	0	0
<b>Minerals</b>			Vitamin E (alpha-tocopherol) (mg)	0.12	0.12
Calcium (mg)	64	62	Vitamin D (D2 + D3) (μg)	0	0
Iron (mg)	0.98	1.79	Vitamin D IU	0	0
Magnesium (mg)	35	36	Vitamin K (phylloquinone) (μg)	3.5	3.5
Phosphorus (mg)	101	98	<b>Lipids</b>		
Potassium (mg)	746	744	Fatty acids (total saturated) (g)	0.065	0.094
Sodium (mg)	24	26	Fatty acids (total monounsaturated) (g)	0.014	0.024
Zinc (mg)	0.37	0.36	Fatty acids (total polyunsaturated) (g)	0.057	0.053
<b>Vitamins</b>			Fatty acids (total trans) (g)	0	0.001
Vitamin C (total ascorbic acid) (mg)	3.20	2.30	Cholesterol (mg)	0	0
Thiamin (mg)	0.008	0.106			
<sup>1</sup> DFE (dietary folate equivalents); <sup>2</sup> RAE (retinol activity equivalents); <sup>3</sup> (IU) International Unit.					

Raisin is rich in fiber and phytochemicals. Despite the 60% sugar content in the composition of raisin, it has a low-to-medium glycemic index (USDA 2021). During the drying of the grape, some of the grape sugars turn into fructan, the type of fiber. While fructan was not found in fresh grapes, about 8% of the fructan in raisins was determined. It has been reported that raisins have a high antioxidant capacity in *in vitro* and *in vivo* studies (Camire & Dougherty 2003).

Among dried foods, the highest total phenolic content (mg/kg) was detected in raisins (Olmo-Cunillera *et al.* 2020). It is reported that dark color and seeded grapes have the highest values in terms of total phenolic content among different raisin varieties (Sério *et al.* 2014).

Consuming 80-90 g of raisin (half a cup) in daily nutrition provides many benefits for a healthy life. The low glycemic index makes it a healthy snack. It is the best remedy for sudden hunger crises and suppresses appetite (Olmo-Cunillera *et al.* 2020).

Raisin is a functional product and can be consumed directly or used to enrich various foodstuffs. Different researchers have reported that Raisins, a food rich in terms of antioxidant properties and polyphenol content, have positive effects reducing the response to satiety insulin, lowering cholesterol, protecting against cardiovascular diseases, and preventing colon cancer (Kanellos *et al.* 2013; 2014; 2017 Kaliora *et al.* 2008; 2017; Kim *et al.* 2008; Kountouri *et al.* 2013).

Raisins play an important role, especially in the revival of intestinal flora, in increasing beneficial bacteria (*Faecalibacterium prausnitzii*, *Bacteroidetes sp.* and *Ruminococcus sp.*) and the reduction of harmful bacteria (Wijayabahu *et al.* 2019). Fiber-rich diets have been associated with reduced risk of cardiovascular diseases, constipation, diabetes, colon cancer and obesity (Gol *et al.* 2019). The fiber content in dried fruits together with phytochemical contribute to the decrease of the glycemic response (Viguiliouk *et al.* 2018).

Guidelines prepared for individuals with type 2 diabetes or predisposition include a low glycemic-laden diet. Raisins have a moderate to low glycemic index. The low glycemic index stimulates the mechanisms associated with blood pressure and satiety control (Kim *et al.* 2008; Viguiliouk *et al.* 2018; Zhu *et al.* 2018). It is reported that including raisins in the diet benefits in the prevention of neurodegenerative diseases and Alzheimer's disease (Gol *et al.* 2019). One of the major problems in today's world is a non-alcoholic fatty liver disease (NAFLD) (linked to obesity, type 2 diabetes, and oxidative stress) and steatohepatitis. In this context, Kaliora *et al.* (2016) observed the beneficial effect of raisins on oxidative stress and inflammation markers in NAYKH patients with non-significant fibrosis.

Raisins contain about 62% sugar (monosaccharides, glucose, fructose, and sucrose) (Vasilopoulou & Trichopoulou 2014). Therefore, raisins are easily absorbed in digestion and provide a moderate 'Glycemic Index' (GI) level. Raisins that do not contain total fat and cholesterol have increased interest because they are rich in terms of bioactive components and have a high nutritional value. Raisins are a rich source of dietary fiber and vitamin B complex as well as minerals such as calcium, iron, magnesium, phosphorus, and potassium but contain a low amount of sodium (Vasilopoulou & Trichopoulou 2014; USDA 2021).

Raisins are an important source for boron, a trace element related to bone health, arthritis, and the prevention of osteoporosis in postmenopausal women. Boron also interacts with enzyme reaction, cell membrane function, and hormone metabolism. Boron is also a necessary element for brain function (Gol *et al.* 2019).

Different researchers have reported that grapes and raisins strengthen the immune system, regulate the functioning of the kidney and intestinal system and blood circulation, increase capillary strength and vascular function, help reduce sand and stones in the kidneys, prevent liver diseases, lower bad cholesterol and reduce the risk of vascular obstruction (Aras 2006).

On the composition of raisins, variety, ecology, cultivation, and weather conditions have a dynamic effect. Nikolidaki *et al.* (2017) have examined the impact of growing conditions (altitude) on the moisture, ash, fat, protein content, fructose, glucose, sucrose, maltose of grapes. They have reported that differences in the composition of grapes are observed, but they are not significantly related to final product quality. Panagopoulou *et al.* (2019a) have analyzed the composition of phytochemicals and sugars in the study, examining drying in the sun and shade. They have reported that the individual and total sugar profile does not change significantly due to the drying method. Panagopoulou *et al.* (2019b) have reported that differences between regional cultivation, altitude, and crop years are not considered significant in terms of ingredients of B vitamins, thiamin, thiamin pyrophosphate, nicotinamide, nicotinic acid, pyridoxine, and pyridoxine in Corinthian raisins

Despite known and researched health benefits, raisins have been overlooked in past years. The tendency of consumers with increased awareness towards functional and traditional foods has increased the interest in traditional foods that were previously ignored. While the phenolic content and antioxidant activity of grapes and wines are widely investigated, raisins have been the focus of recent studies (Williamson & Carughi 2010; Papadaki *et al.* 2021).

Research has also been carried out on changes in the phenolic content of raisins during the drying process. Olivati *et al.* (2019) have reported that raisins pretreated with olive oil contained higher amounts of anthocyanin and



proanthocyanidin than untreated grapes. During sun drying of Argentine grapes, it has observed an increase in the phenolic acid and flavonoid concentrations, and more specifically, in the amounts of rutin, kaempferol-hexoside, quercetin, and isoquercitrin (Fabani *et al.* 2017). It is accepted that the drying processes increase the amounts of total phenolic, anthocyanin, and tannins in raisins when compared to fresh grapes (Guiné *et al.* 2015).

Phytochemicals are useful compounds in people's metabolic activities. Epidemiological studies investigate the relationship between functional compounds, nutrition, and genetic. In the studies, it is emphasized that conscious nutrition for a healthy life is important in terms of relief or prevention of the disease.

It is seen as important to develop functional food products that contain bioactive components and to expand the consumption of foods rich in bioactive compounds such as raisins in diets. Antioxidant activities with total phenolic and flavonoid contents of white and seedless varieties were found lower than black and seeded varieties (Kelebek *et al.* 2013).

Phenolic compounds (anthocyanidin, proanthocyanidin, stilbene, and phenolic acid), found in quite a large amount in the skin and seeds of black grapes, help prevent diseases caused by oxidative stress. They also have antioxidant, anticancer, anti-inflammatory, and antibacterial properties (Genç 2011).

Component	Bioactive Classification	Potential Benefit
Boron	Mineral	<ul style="list-style-type: none"> <li>Supports growth of healthy bones</li> <li>Maintains healthy bones and joints</li> </ul>
Fiber, including Pectin	Non-digestible carbohydrate	<ul style="list-style-type: none"> <li>Colon cancer protection</li> <li>Cholesterol lowering</li> <li>Protection from cardiovascular disease</li> <li>Support of colon health and function</li> </ul>
Pectin	Non-digestible carbohydrate	<ul style="list-style-type: none"> <li>Cholesterol lowering</li> </ul>
Fructans	Prebiotic	<ul style="list-style-type: none"> <li>Stimulation of health-promoting colonic microflora</li> <li>Support of colon health</li> <li>Stimulation of calcium and magnesium absorption</li> </ul>
Tartaric acid		<ul style="list-style-type: none"> <li>Colon cancer protection</li> <li>Support of colonic health and function</li> <li>Enhance mineral absorption</li> </ul>
Flavonols (e.g. quercetin and kaempferol)	Flavonoids (Polyphenols)	<ul style="list-style-type: none"> <li>Antioxidants, protection from oxidative stress</li> <li>Cardiovascular disease protection</li> <li>Cancer protection</li> <li>Anti-inflammatory</li> <li>Protection from age-related neurological degeneration</li> </ul>
Hydroxycinnamic acids and derivatives (e.g. caftaric and coumaric acids)	Phenolic acids	<ul style="list-style-type: none"> <li>Antioxidants, protection from oxidative stress</li> <li>Cancer protection</li> <li>Anti-inflammatory</li> </ul>
Isoflavones: Daidzein and genistein	Phytoestrogens (Polyphenols)	<ul style="list-style-type: none"> <li>Antioxidants, protection from oxidative stress</li> <li>Cancer protection (breast, prostate, colon)</li> <li>Cardiovascular disease protection</li> <li>Osteoporosis protection</li> <li>Alleviate menopausal symptoms</li> </ul>
Betulin, oleanolic and betulinic acids	Triterpenes	<ul style="list-style-type: none"> <li>Anti-cavity, gum disease protection</li> </ul>

Figure 3. Physiological effects of raisin compound. (Carughi *et al.* (2008)

As a general evaluation, raisins are both wonderful food and a sweet and pleasant remedy that is beneficial to many diseases. Considering all the benefits, it must be included in the nutrition habits. Grapes, which are important food and snacks for today's people who are tired of many diseases, should be included in the diet so that humanity can stay healthy. Carughi *et al.* (2008) have summarized the physiological effects of compounds in raisins as presented in Figure 3.

### 3. Uses of Grape in Folk Medicine

*Vitis vinifera* L. is a perennial, woody, and temperate climate plant, and its different parts have been used in folk medicine for centuries due to its many biological activities (Şendoğdu 2004; Khalil *et al.* 2007). Different societies and cultures continue the practices they have experienced in the past and are seen as helpful today. People have sought natural remedies against diseases that affect them. They have tried to improve with various trial and error methods and applications. Thus, folk medicine and practices have emerged. According to Kaplan (2011), folk medicine is also called 'local medicine'. The benefits obtained have been transferred from generation to generation and turned into oral health information.

Today, the pharmaceutical industry is inspired by this, natural antioxidant substances extracted from different parts of grape such as the leaf, seed, berry, skin, and pulp are used in cosmetic products, in the composition of drugs, in foods as additives, and sold as a nutritional supplement in pharmacies (Makris *et al.* 2007; Doshi *et al.* 2006; Kunter *et al.* 2013).

- ✓ Naturel remedies obtained from grape have been used among the public in venous diseases, circulatory disorder, headache, dysphoria, scabies, skin diseases, gonorrhoea, hemorrhoids, and vomiting (Demirezer 2011).
- ✓ It is believed that raisins and molasses are good for anemia. Those who have anemia problems are fed plenty of raisins. In this treatment, seeded raisins are generally preferred. Molasses is consumed hungrily in the morning during the winter months. Grape juice is also consumed to make blood. Black grape seeds are eaten for anemia by mixing with yogurt (Batu 1993; Batu 2011).
- ✓ For flu and cold, the patient is drunk molasses or vinegar. Vinegar is also used to reduce fever in feverish diseases. Raki obtained from the grape is also used in the treatment of cold (Yankı 2013).
- ✓ Use in wounds, bruises, sprains, fractures, and dislocations. Crushed grapes with seeds are wrapped on the sprained area of the patient who has sprained hand or foot. In this application, especially black seeded grapes are

preferred. It is also seen that only grape seeds are used in sprains (Yeşilada 2012). If crushed raisin is cooked, wrapped warmly on the bruise, and left for one night, it heals the bruise (Gürkan 2014).

- ✓ Keeping the chewed grape in the mouth for a while is used to treat mouth sores (Yeşilada 2012).
- ✓ Grape and products obtained from the grape are used to treat sore throat and cough. Especially molasses is one of the most common products used in the treatment of cough. For sore throat, it is recommended to eat seedless grape and fig mixed with almond oil every morning (Baytop 1999)
- ✓ Treatment methods applied in low back pain. Those who suffer from low back pain wrap the crushed grape on their waist, wait for a day or two, and then remove it.
- ✓ Treatment methods are applied in the eye and ear treatment. Unripe grape juice is used in the treatment of wounds around the eye and eye diseases. Unripe grape juice is squeezed into the ear and is known to be good for ear infections (Gürkan 2014).
- ✓ The treatment method is applied in having a child. The childless woman is seated on the grape pomace. It is believed that the woman who does this will have a child. The second application about having a child is done by treating the inflammation in the uterus. For this, crushed grapes are mixed with spices and placed in the cervix in a ball form. At the same time, the woman's navel is pulled to ensure that the childless woman becomes pregnant. Raisin and black cumin are crushed and mixed with tallow and wrapped on the women's abdomen to relax the muscles stuck in the ovaries (Gürkan 2014).
- ✓ Treatment methods applied in forgetfulness. School-age children and older people should consume grapes, raisins and molasses. There is a strong belief that when they consume these products, their forgetfulness will disappear (Gürkan 2014).
- ✓ For stronger and shiny hairs, the crying water of the vine is mixed with water and the hairs are washed with this mixture (İlçim, 2014).
- ✓ Ingestion of black seeded grapes appears as the elixir of beauty, real brain food, and weight-loss regimens' main product. It is also believed to dilute the blood like aspirin and protect against heart diseases (Gürkan 2014).
- ✓ In the past, physicians recommended the use of a grape cure. It is stated that eating 3-4 kilos of grapes a day in the morning, noon, and evening heals stomach ailments, rejuvenates and renews the body (Gürkan 2014).
- ✓ To ripen boil in any part of the body, when crushed raisin is wrapped on boil for 12-24 hours, it ensures ripening and healing of the boil.

- ✓ It is recommended to drink grape vinegar on an empty stomach to stop diarrhea (Gurkan 2014).
- ✓ In many Mediterranean countries, especially in folk medicine, vine leaves are used as food and medicine to treat various diseases (hepatitis, stomachaches, diarrhea, anti-hemorrhoids, antiseptic, antianemia, diuretic) (Bombardelli & Morazzoni 1995; Baytop 1999; Orhan *et al.* 2006).
- ✓ It is stated that fresh vine leaves are used externally to heal wounds and open boils (Gürkan 2014).
- ✓ The juice of grape leaves is also used as an antiseptic for eye bathing (Baytop 1999)
- ✓ Black grape leaves with high tannin content are used as constipation reliever and blood stopper; fresh leaves are used externally as wound healers and boil-opener (Baytop 1999).
- ✓ Vine leaves are commonly used to lower blood sugar in diabetes and as a tonic in hepatitis (Demirezer 2011).
- ✓ Since ancient times, *Vitis vinifera* L. leaves have been used in medicine. Vine leaves have various biological activities, including antibacterial, antifungal, anti-inflammatory, antiviral and mainly antioxidant properties as well as hepatoprotective, spasmolytic, hypoglycemic vasodilator effects (Fernandes *et al.* 2013). Vine leaves have been used in Anatolian and Mediterranean cuisine since ancient years. A similar culinary tradition is found in Balkan countries such as Greece, Albania, Bulgaria and Mediterranean countries with extensive vineyards as France and Spain (Er 2006).
- ✓ For stronger and shiny hairs, the crying water of the vine is mixed with water and the hairs are washed with this mixture (İlçim, 2014).
- ✓ It is recommended to drink grape vinegar on an empty stomach to stop diarrhea (Gürkan 2014).

The cultivation of grape that offers rich flavors has spread worldwide. Grape and grape products are important food sources due to their different tastes, nutritional values, and multifaceted effects on health.

When the use of grapes in folk medicine and the benefits presented in Figure 2 are compared, it is seen that there are many common aspects. It is understood that the applications determined to be beneficial with experiences in folk medicine are not vain. It should be stated that we cannot say that the same should be done today. But human-beneficial applications can be applied. At least grape and grape products can be eaten and drunk. Thus, we can benefit from the benefits of this magnificent fruit for our health. The cultivation of grape that

offers rich flavors has spread worldwide. Grape and grape products are important food sources due to their different tastes, nutritional values, and multifaceted effects on health. We can benefit from the benefits of this magnificent fruit for our health.

Natural and healthy nutrition, which has become the focus of attention in daily life, is becoming more widespread. Consumers are becoming more and more aware of this issue day by day. The points mentioned above show that there is no need to look far for the beneficial and healing ones. Raisins and grape products are among the nutrients that must be consumed in daily eating habits due to their rich nutritional content and bioactive benefits arising from phenolic substances.

## References

- Abuajah CI; Ogbonna AC & Osuji CM (2015). Functional components and medicinal properties of food. A review. *J. Food Sci. Technol.* 52: 2522-2529.
- Aras Ö (2006). Üzüm ve üzüm ürünlerinin toplam karbonhidrat, protein, mineral madde ve fenolik bileşik içeriklerinin belirlenmesi (yüksek lisans tezi). Süleyman Demirel Üniversitesi, Fen Bilimleri Enstitüsü, Isparta.
- Ashwell M (2004). Concepts of functional food. *Nutr. Food Sci.*34: 47.
- Batu A (2011). Grapes, molasses and human health. *Gıda Teknolojileri Elektronik Dergisi* 6 (2): 25-35
- Batu A. (1993). The importance of raisins and molasses in terms of human health and nutrition. *Gıda* 18 (5): 303-307
- Baytop T (1999). Therapy with medicinal plants in Türkiye (Past and present). Istanbul University Türkiye.
- Bombardelli E & Morazzoni P (1995). *Vitis vinifera* L. *Fitoterapia*. 66: 291-317.
- Camire ME & Dougherty MP (2003). Raisin dietary fiber composition and in vitro bile acid binding. *J. Agric. Food Chem.* 51 (3): 834-837.
- Carughi A; Lamkin T & Perelman D (2008). Health benefits of sun-dried raisins. Available online: [http://www.raisins.net/Raisins\\_and\\_Health\\_200810.pdf](http://www.raisins.net/Raisins_and_Health_200810.pdf) (accessed on 05 September 2019).
- Deliorman OD, Ergun F & Orhan N (2011). Anadolu medeniyetlerinde asma (*Vitis vinifera* L.). *Tarih Araştırmaları Dergisi*, 30 (50), 69-80.
- Demirezer LÖ (2011). Fed monografıları, tedavide kullanılan bitkiler, (Edt) MN Medikal & Nobel Yayıncılık Ankara
- Di Lorenzo C; Frigerio G; Colombo F; de Sousa LP; Altındışli A; Dell'Agli M & Restani P (2016). Phenolic profile and antioxidant activity of different

raisin (*Vitis vinifera* L.) samples. BIO Web Conf. 7:1-7. doi: 10.1051/bioconf/20160704006.

Doshi P; Adsule P & Banarjee K (2006). Phenolic composition and antioxidant activity in grapevine parts and berries (*Vitis vinifera* L.) cv. Kishmish Chornyi (Sharad Seedless) during maturation. International Journal of Food Science and Technology 41 (Supplement 1): 1-9.

Er A (2006). Bağlar güzeli: Üzüm ve üzüm kültürü (1). Özpabalıyıklar S (Edt) Yapı Kredi Kültür ve Sanat Yayıncılık Ticaret ve Sanayi A.Ş. İstanbul.

Fabani MP; Baroni MV; Luna L; Lingua MS; Monferran MV; Paños H; Tapia A; Wunderlin DA & Feresin GE (2017). Changes in the phenolic profile of Argentinean fresh grapes during the production of sun-dried raisins. J. Food Compos. Anal. 58: 23-32.

Fernandes F; Ramalhosa E; Pires P; Verdial J; Valentão P; Andrade P; Bento A & Pereira JA (2013). *Vitis vinifera* L. leaves towards bioactivity. Ind. Crops Prod. 43 :434-440.

Fulgoni VL; Painter J & Carughi A (2017). Association of raisin consumption with nutrient intake, diet quality, and health risk factors in US adults: National Health and Nutrition Examination Survey 2001-2012. Food & Nutrition Research 61 (1): 1-8.

Genç H (2011). *Olea europaea* L. ve *Vitis vinifera* L. ekstraktlarının biyolojik aktivitelerinin değerlendirilmesi ve ara ürün formülasyonunun geliştirilmesi. (Yüksek Lisans Tezi) Anadolu Üniversitesi Fen Bilimleri Enstitüsü İleri Teknolojiler Anabilim Dalı, Biyoteknoloji Bilim Dalı.

Göktaş A (2008). Üzüm Yetiştiriciliği, Eğirdir Bahçe Kültürleri Araştırma Enstitüsü Yayın No: 18, 22s.

Gol M; Ghorbanian D; Soltanpour N; Faraji J & Pourghasem M (2019). Protective effect of raisin (currant) against spatial memory impairment and oxidative stress in Alzheimer disease model. Nutr. Neurosci. 22: 110-118.

Guiné RPF; Almeida IC; Correia AC & Gonçalves FJ (2015). Evaluation of the physical, chemical and sensory properties of raisins produced from grapes of the cultivar Crimson. J. Food Meas. Charact. 9: 337-346.

Gürkan H., 2014. Asma bitkisinin tarih boyunca önemi ve günümüzde kullanımı. Erciyes Üniversitesi Eczacılık Fakültesi, 106 s.

İlçim, A. (2014). Hatay Tabiat Şifahanesi. TC Hatay Valiliği.

Kaliora AC; Kanellos PT; Gioxari A & Karathanos VT (2017). Regulation of GIP and Ghrelin in healthy subjects fed on sun-dried raisins: A pilot study with a crossover trial design. J. Med. Food 20: 301-308.

- Kaliora AC; Kokkinos A; Diolintzi A & Stoupaki M (2016). Function the effect of minimal dietary changes with raisins in NAFLD patients with non-significant fibrosis: A randomized controlled intervention. *Food Funct.* 7: 4533-4544.
- Kaliora AC; Kountouri AM; Karathanos VT; Koumbi L; Papadopoulos NG & Andrikopoulos NK (2008). Effect of Greek raisins (*Vitis vinifera* L.) from different origins on gastric cancer cell growth. *Nutr. Cancer* 60 :792-799.
- Kanellos PT; Kaliora AC; Gioxari A; Christopoulou GO; Kalogeropoulos N & Karathanos VT (2013). Absorption and bioavailability of antioxidant phytochemicals and increase of serum oxidation resistance in healthy subjects following supplementation with raisins. *Plant. Foods Hum. Nutr.* 68: 411-415.
- Kanellos PT; Kaliora AC; Protogerou AD; Tentolouris N; Perrea DN & Karathanos VT (2017). The effect of raisins on biomarkers of endothelial function and oxidant damage; an open-label and randomized controlled intervention. *Food Res. Int.* 102: 674-680.
- Kanellos PT; Kaliora AC; Tentolouris NK; Argiana V; Perrea D; Kalogeropoulos N; Kountouri AM & Karathanos VT (2014). A pilot randomized controlled trial to examine the health outcomes of raisin consumption in patients with diabetes. *Nutrition* 30: 358-364.
- Kaplan M (2011) Halk tıbbının kökenleri: teşhisten tedaviye din ve büyü ilişkisi. *Milli Folklor Dergisi* 91:150-156.
- Kelebek H; Jourdes M; Selli S & Teissedre PL (2013). Comparative evaluation of the phenolic content and antioxidant capacity of sun-dried raisins. *Journal of the Science of Food and Agriculture* 93 (12): 2963-2972 Doi: 10.1002/Jsfa.6125.
- Khalil MY; Moustafa AA & Naguib NY (2007). Growth, phenolic compounds and antioxidant activity of some medicinal plants grown under organic farming condition”, *World Journal of Agricultural Sciences*, 3(4): 451-457.
- Kim Y; Hertzler SR; Byrne HK & Mattern CO (2008). Raisins are a low to moderate glycemic index food with a correspondingly low insulin index. *Nutrition Research* 28: 304-308
- Kountouri AM; Gioxari A; Karvela E; Kaliora AC; Karvelas M & Karathanos VT (2013). Chemopreventive properties of raisins originating from Greece in colon cancer cells. *Food Funct.* 4: 366-372.
- Kunter B; Cantürk S & Keskin N (2013). Histochemical structure of grape berry. *Iğdır Univ. J. Inst. Sci. & Tech.* 3(2): 17-24.



- Küster-Boluda I & Vidal-Capilla I (2017). Consumer attitudes in the election of functional foods. *Span. J. Marketing ESIC* 21: 65-79.
- Makris DP; Boskou G & Andrikopoulos NK (2007). Polyphenolic content and in vitro antioxidant characteristics of wine industry and other agri-food solid waste extracts. *J Food Compos Anal* 20: 125-132.
- Mohamed S (2014). Functional foods against metabolic syndrome (obesity, diabetes, hypertension and dyslipidemia) and cardiovascular disease. *Trends Food Sci. Technol.* 35: 114-128.
- Mutlu B (1977). *Batı Sanatında Biçimlenme ve Doğu Akdeniz. İstanbul Güzel Sanatlar Akademisi Yayınları, İstanbul, s. 89.*
- Nikolidaki EK; Chiou A; Christea M; Gkegka AP; Karvelas M & Karathanos VT (2017). Sun-dried Corinthian current (*Vitis vinifera* L. var. Apyrena) simple sugar profile and macronutrient characterization. *Food Chem.* 221: 365-372.
- Olivati C; De Oliveira Nishiyama YP; De Souza RT; Janzantti NS.; Mauro MA; Gomes E; Hermosín-Gutiérrez I; Da Silva R & Lago-Vanzela ES (2019). Effect of the pre-treatment and the drying process on the phenolic composition of raisins produced with a seedless Brazilian grape cultivar. *Food Res. Int.* 116: 190-199.
- Olmo-Cunillera A; Escobar-Avello D; Perez AJ; Marhuenda-Munoz M; Lamuela-Raventos RM & Vallverdu-Queralt A (2020). Is eating raisins healthy? *Nutrients* 12: 54.
- Orhan N; Aslan M; Orhan DD; Ergun F & Yesilada E (2006). In vivo assessment of antidiabetic and antioxidant activities of grapevine leaves (*Vitis vinifera* L.) in diabetic rats. *J. Ethnopharmacol.* 108: 280-286.
- Palomino O; Gomez-Serranillos MP; Slowing K; Carretero E & Villar A (2000). Study of polyphenols in grape berries by reversed-phase high-performance liquid chromatography. *Journal of Chromatography A*, 870(1-2): 449-451.
- Panagopoulou EA; Chiou A; Nikolidaki EK; Christea M & Karathanos VT (2019a). Corinthian raisins (*Vitis vinifera* L., var. Apyrena) antioxidant and sugar content as affected by the drying process: A 3-year study. *J. Sci. Food Agric.* 99: 915-922.
- Panagopoulou EA; Chiou A & Karathanos VT (2019b). Water-soluble vitamin content of sun-dried Corinthian raisins (*Vitis vinifera* L. var. Apyrena). *J. Sci. Food Agric.* 99: 5327-5333.
- Papadaki A; Kachrimanidou V; Lappa IK; Eriotou E; Sidirokastritis, N; Kampioti A & Kopsahelis N (2021). Mediterranean raisins/currants as traditional superfoods: processing, health benefits, food applications and future trends within the bio-economy Era. *Appl. Sci.* 11: 1605.

- Proestos C (2018). Superfoods: Recent data on their role in the prevention of diseases. *Curr. Res. Nutr. Food Sci.* 6
- Sağlam ÖÇ, & Sağlam H (2018). İnsanlık tarihinde üzümün önemi. *Journal of Agriculture*, 1(2), 1-10.
- Salanță LC; Uifălean A; Iuga CA; Tofană M; Crototova J; Pop, OL; Pop CR; Rotar MA; Ávila MB & Velázquez González CV (2020). Valuable food molecules with potential benefits for human health. in the health benefits of foods—current knowledge and further development; Salanță, L.C., Ed.; Intech Open: London, UK, Available online: <https://www.intechopen.com/books/the-health-benefits-of-foods-current-knowledge-and-further-development/valuable-food-molecules-with-potential-benefits-for-human-health> (accessed on 2 February 2021).
- Şamil A; Tezcan R; Ceylan N & Erçetin M (2005). Şarkıkaraağaç yöresinde yetiştirilen üzüm çeşitlerinde bakır ve çinko tayini, *KSÜ Fen ve Mühendislik Dergisi* 8 (1).
- Schaffer S & Halliwell B (2012). Do polyphenols enter the brain and does it matter? Some theoretical and practical considerations. *Genes Nutr.* 7 :99-109.
- Şendoğdu N (2004). *Vitis vinifera* L. yapraklarının şeker hastalığı üzerindeki etkilerinin araştırılması (Yüksek Lisans Tezi), Gazi Üniversitesi, Sağlık Bilimleri Enstitüsü, Farmakognozi Anabilim Dalı, Ankara.
- Sério S; Rivero-Pérez MD; Correia AC; Jordão AM & González-San José ML (2014). Analysis of commercial grape raisins: Phenolic content, antioxidant capacity and radical scavenger activity. *Ciência e Técnica Vitivinícola.* 29:1–8. doi: 10.1051/ctv/20142901001.
- Shahidi F & Tan Z (2013). Raisins: Processing, phytochemicals, and health benefits. In *Dried Fruits*; Alasalvar, C., Shahidi, F., Eds.; John Wiley & Sons, Inc.: Hoboken, NJ, USA, pp. 372-392. ISBN 9780813811734.
- Sreenivasan L & Watson RR (2015). Chapter 14 - Reduction is the New Youth: The Effect of Polyphenols on Brain Aging and Diseases. In *Bioactive Nutraceuticals and Dietary Supplements in Neurological and Brain Disease Prevention and Therapy*; Watson, R.R., Victor, R.P., Eds.; Academic Press (Elsevier): Amsterdam, The Netherlands :137-140.
- Trichopoulou A; Vasilopoulou E; Georga K; Soukara S & Dilis V (2006). Traditional foods: Why and how to sustain them. *Trends Food Sci. Technol.*17: 498-504.
- Uhri A (2017). Üzümün Doğu Akdeniz'deki Uzun Yolculuğu. Üzümün Akdeniz'deki Yolculuğu Konferans Bildirileri, 11-17.

- USDA (2021). Food Composition Databases. Available online: <https://ndb.nal.usda.gov/ndb/>(accessed on 15 August 2021).
- Vasilopoulou E & Trichopoulou A (2014). Greek raisins: A traditional nutritious delicacy. *J. Berry Res.* 2014, 4, 117-125.
- Viguiliouk E; Jenkins AL; Blanco Mejia S; Sievenpiper JL & Kendall, CWC (2018). Effect of dried fruit on postprandial glycemia: A randomized acute-feeding trial. *Nutr. Diabetes* 8 (59)
- Wijayabahu AT; Waugh SG; Ukhanova M & Mai V (2019). Dietary raisin intake has limited effect on gut microbiota composition in adult volunteers. *Nutr. J.* 18 (14)
- Williamson G & Carughi A (2010). Polyphenol content and health benefits of raisins. *Nutrition Research*, 30:511–519.
- Xia N; Liu L; Harrington MG; Wang J & Zhou F (2010). *Analytical Chemistry*, 82: 10151-10157.
- Yang CS, Lambert JD, Ju J, Lu G & Sang S (2007). Tea and cancer prevention: molecular mechanism and human relevance. *Toxicology and Applied Pharmacology*, 224: 265-273.
- Yankı M (2013). *Periler diyarında şarap yolculuğu*. Ankara: Ajansmat.
- Yeşilada E (2012). *İyileştiren bitkiler (2)*, Doğan N. (Edt), Hayy Kitap, İstanbul.
- Zhu R; Fan Z; Dong Y; Liu M; Wang L & Pan H (2018). Postprandial glycaemic responses of dried fruit-containing meals in healthy adults: Results from a randomized trial. *Nutrients* 10: 694.

# CHAPTER 13

## SUSTAINABLE AGRICULTURE AND GENETICALLY MODIFIED ORGANISMS (GMOs)

Enes FİDAN<sup>1</sup> & Işık TEPE<sup>2</sup>

<sup>1</sup>(Res. Assist.), Van Yüzüncü Yıl University, Faculty of  
Agriculture, Department of Plant Protection, Van, Türkiye,  
e-mail:enesfidan@yyu.edu.tr

 0000-0002-4567-2375

<sup>2</sup>(Prof. Dr.), Van Yüzüncü Yıl University, Faculty of Agriculture,  
Department of Plant Protection, Van, Türkiye

e-mail: itepe@yyu.edu.tr

 0000-0002-9156-9467

### 1. Introduction

The process of understanding nature by human beings dates back to ancient times, and the scientific and technological developments made over time have increased the possibility of people to use natural resources. Sustainable development is a concept that seeks to meet the needs and expectations of human beings by putting forward scenarios about the current situation and future of the world. Therefore, social issues (such as poverty, health, education and culture) and the use of natural resources aim to establish a balance between the production and consumption. The emergence of the concept of sustainable development started with the ‘Green Revolution’, which was accepted as an important invention to meet the food needs of the world population in the 1940s. (Pezikoğlu 2006; Teksöz 2014).

The word for sustainability comes from the Latin word *sustinere* (sus; from below and tinere; to hold) and includes existence, maintenance, long-term support or continuity. Being agriculturally sustainable describes agricultural systems that have the capacity to maintain their productivity and are beneficial to social instability. These systems should be resource-conserving, socially

supported, commercially competitive and environmentally conscious (Gold 1999; Rigby & Bown 2003).

The concept of sustainability has emerged as the desired balance between the economic activities and environment in order not to destroy the environment in the name of economic growth and development. This concept is defined as meeting the needs of the population living today without compromising the needs of future generations by using and protecting natural resources in the long term. The concept of sustainable agriculture, on the other hand, is expressed as the long-term protection of natural resources and guaranteeing their productivity by establishing an economically, socially and environmentally balanced agricultural system. Sustainable agriculture aims to obtain products in sufficient quantity and quality to be sensitive to the environment and to keep all types of pollution that may occur at a minimum level with appropriate agricultural systems. In addition, the sustainable agriculture, within the scope of modern agricultural techniques, also refers to a structural transformation by using alternative energy sources in order to reduce the high costs caused by conventional farming methods in rural areas (Karaca 2013). While describing the sustainable agriculture, many definitions have been made in connection with the cultures and ecologies of the countries. Berry made a brief definition as '*sustainable agriculture does not deplete people or land*'. Sustainable agriculture is considered to be a positive approach to the constraints and problems of both traditional and modern agriculture. At the same time, it is aimed to carry out integrated studies in sustainable agriculture by using the wisdom of traditional farming systems and the technological superiority of modern agriculture (Pezikoğlu 2006).

The creation of an environmentally sustainable agricultural structure will only be possible if agricultural activities are economical. The development of sustainable agriculture depends on the cost of agricultural practices that protect natural resources and the environment. For this reason, the long-term applicability of sustainable agriculture should be evaluated with both the environmental and economic components (Eryılmaz & Kılıç 2018).

There are alternative methods to chemical control such as integrated control and biological control in sustainable agricultural practices. The integrated control methods, which are included in sustainable agricultural practices, are a system that takes into account human health, natural balance and the environment (Crucefix 1998). The integrated control is a pest management system that keeps the populations below the economic damage level by using all appropriate control methods in harmony with each other, taking into account the relationship of diseases, pests and weeds with the environment. In integrated

control, it is aimed to increase yield and quality, obtain products without pesticide residues, periodically control agricultural areas, make producers experts in their own fields, gardens or vineyards, and to prevent the contamination of chemical pesticide residues to the environment (Atış 2004). The main indicators of sustainable agriculture are shown in Table 1.

Table 1. Main Indicators of Sustainable Agriculture (Turhan 2005).

Indicators	Determinant
Long-term income of the producer	Long-term producer income Increasing marketing networks for manufacturers and developing exports Effective use of resources
Natural resources	Ensuring food quality and safety Improving condition of the soil Product variety Water resources Chemical waste Salinity in water
Environment	The effect of agriculture on natural resources
Managerial features	Dissemination of training programs for the correct use of sustainable agricultural practices
Socio-economic effects	Ensuring human-oriented developments in agriculture and conducting training studies

It is predicted that the world population will exceed eight billion by 2025 and meeting the nutritional needs of this population will be an important problem. Therefore, it is necessary to increase the yield per unit area, since arable agricultural lands are at the last limit in order to meet the food need. Due to the high cost and impracticality of classical plant breeding methods, the use of new plant breeding technologies has become inevitable (Atsan & Kaya 2008).

Organisms obtained by changing the genes of living things with biotechnological methods, changing their existing characteristics or gaining new ones are called the 'Genetically Modified Organisms' (GMOs) (Kulaç & Ağirdil 2006; Haspolat 2012). The purpose in gene transferred (transgenic) plants is to increase the product quality by improving the nutritional value, processing and preservation properties of the products with low agricultural production cost resistant to diseases and pests (Demir *et al.* 2005). The stability in genetically

modified plants can vary depending on stress factors such as disease, pest, temperature, water and nutrient status of the plant (Craig *et al.* 2008).

The first transformation into plants was carried out as a result of transferring *Agrobacterium tumefaciens*, which causes root cancer, to the plant genome by the application of gene transfer. In some cereals (wheat, barley, oats, etc.) that are not compatible with *Agrobacterium* this transformation has been carried out using micrometer-sized particles coated with DNA, known as gene weapon or ‘micropipet bombardment’, which are randomly transferred to plant cells. Many transgenic plants produced to date have been obtained after breeding using *Agrobacterium* or by gene weapon (Stewart *et al.* 2000). After these breeding studies, the genetically modified plants with a long shelf life were developed for many products, especially tomatoes, between 1983-1989 (Bawa & Anilakumar 2013). The first commercially genetically modified plant is the tomato plant called ‘Flavr Savr’, which has a long shelf life (Şen & Altınkaynak 2014). In 1995, the genes of *Bacillus thuringiensis* (Bt) bacteria were transferred to the corn plant to increase its resistance against insects (Ince *et al.* 2013). The first transgenic studies on the potato plant were made in the USA in 1995, and the CryIIIa gene was transferred to the potato to provide resistance against the Colorado potato beetle (Arvas *et al.* 2018). Monsanto company produced the first approved genetically modified (GM) crop, Round-Up Ready® (RUR) soybean, and introduced it to the market in 1996 (Ujhelyi *et al.* 2008).

## 2. Current Situation of Sustainable Agriculture and GMOs

The developments in the production and use of genetically modified plants in the world are monitored and determined by considering their contribution to the economy of the countries. In recent years, significant progress has been made in the formulation of biotechnology policies in developed countries. In Türkiye, however, the modern biotechnology and the herbal biotechnology involved in it are still in their infancy, and commercial production of genetically modified plants is not legally available at present (Cirik *et al.* 2017).

### 2.1. Sustainable Agriculture

The term ‘Sustainable Agriculture’ was first used in 1983 by Perlas *et al.* Perlas *et al.* (1983) pioneered the establishment of the International Sustainable Agricultural Cooperation organization and provided the worldwide discussion of the concept of sustainability. Over the past years, Perlas has introduced the seven dimensions of the concept of sustainable agriculture, making it nationally



and internationally accepted. For example, the Sustainable Agriculture Coalition, formed by nearly 300 organizations in the USA, also supports this structure created by Perlas (Gençler 2009). The American National Research Council evaluated the sustainable agriculture under five main headings in 1989 (Perlas *et al.* 1993; Açüksöz 2001):

- To focus more on natural ways such as “nitrogen fixation, nutrient cycling and harmful predator” relationships in agricultural production,
- To reduce the use of non-agricultural inputs that are harmful to humans and the environment,
- To use plant and animal resources more efficiently,
- To provide the most suitable product patterns for the planting rotation,
- Soil, water, energy and biological resources must be protected and used and managed sensitively.

In the last century, the development of technology and the increase in population in the world caused imbalances in the use of resources. The inefficient use of resources harms the environment and humanity. The concept of protection and sustainability, which was first introduced by developed countries, attracted the attention with the initiation of environmental movements in the 1970s. The important events that took place after the 1970s on the environment, the use of resources and sustainable agriculture can be listed as follows (Yıldırım & Öner 2003; Pezikoğlu 2006; Türkmen 2007; Tıraş 2012; Yeşil 2016; Eryılmaz & Kılıç 2018):

- 1970- Environmental movements started in response to the irregular use of resources and pollution of the environment.
- 1971- The environmental issue came to the fore with the studies carried out by the non-governmental organization “Greenpeace” on the environment.
- 1972- The Club of Rome’s ‘The Limits to Growth’ study focused on how the world’s development trends could cause problems.
- 1972- After the Human Environment Conference held by the United Nations in Stockholm, the UN Environment Program came into effect.
- 1983- The Association of Sustainable Agriculture was established, which includes many countries in the world.
- 1987- The principle of sustainability was set forth in the Brundtland report published by the United Nations. Many countries around the world have decided to implement this report, taking into account their national interests.

- 1992- At the Earth Summit held in Rio de Janeiro, an action program was developed in which the principle of sustainability is at the center of the international level. In this program, the importance of integrated planning and management of land resources in subjects such as sustainable agriculture and rural development was emphasized.
- 1999- In the European Council Reports held in Berlin, the issue of sustainable agriculture was widely covered.
- 2002- At the World Sustainable Development Summit held in South Africa, the components of sustainable development were determined, especially on the issues such as environmental protection, economic and social development.
- As a result of the United Nations Conference on Sustainable Development held by the United Nations in 2012, the final declaration titled “The Future We Want” was published and Rio principles and previous action plans were re-approved in the text of the declaration.
- 2015- The United Nations Sustainable Development Summit held in New York aimed to strengthen the global partnership for sustainable development and ensure the world peace.

Although the studies on sustainable agriculture in Türkiye show parallelism with the studies in the world, it is seen that the institutions and organizations related to the agricultural sector have entered the field of application a little late in the harmonization processes. Although the production and trade related to the organic agriculture began in 1986, the first regulation on the subject was issued in 1994. The sustainable agriculture is generally considered with the sustainable development. In the 5<sup>th</sup> and 7<sup>th</sup> Five-Year Development Plans, the protection of natural resources and leaving a natural, physical and social environment to future generations in a way that will enable sustainable economic development have been adopted as the basic principle and policy (Pezikoğlu 2006).

## **2.2. Genetically Modified Organisms (GMOs)**

There are very harsh reactions against the Genetically Modified Organisms in the world (Tukelman 2017). In order to ensure the safety of food supply, the legal regulations are introduced for marketing or cultivation of genetically modified products (Zimny *et al.* 2019). The organization called the International Service for the Acquisition of Agri-Biotech Applications (ISAAA) provides a detailed report of GM crops every year around the world. According to the

report of this organization; the first field trials started with tobacco in the USA and France in 1986, and many field trials have been conducted with eight agricultural products until 1995. These agricultural products, which were field tested are canola (21%), potatoes (11%), tomatoes (11%), corn (11%), soybeans (9%), cotton (7%), tobacco (5%), melons and zucchini (3%). With these developments, while the production of transgenic plants in the world was approximately 1.6 million hectares in 1996, it increased approximately 100 times and reached 165 million hectares in 2015. While GM crops were grown mostly (57%) in industrialized countries in the first years, the cultivation of these crops started to increase rapidly in developing countries after 2015. According to 2015 data, the countries such as the USA, China and Argentina are at the forefront of the countries that oppose GM crops, while the production and consumption of GM crops has increased rapidly in these countries (Tukelman 2017).

The production of genetically modified crops increased approximately 113 times between 1996 and 2018, reaching a total production area of 191.7 million hectares. In 2018, the GM crops cultivation were made in 26 countries in total, and the top three countries with the most plantings were the USA, Brazil and Argentina, respectively. In 2018, the transgenic crops resistant to herbicides were planted on 88 million hectares of land, while the insect-resistant transgenic crops were planted on 23 million hectares (Arvas & Kocaçalışkan 2020). The glyphosate-resistant GM soybeans and corn have been applied in the grassland areas of Argentina, Brazil, Paraguay and Uruguay since the 1990s (Pengue, 2016). According to a study, it was reported that the use of GM crops resulted in an increase in crop yield by 22%, while reducing the use of pesticides by 37% (Klumper & Qaim 2014).

The field trials of GM plants have been carried out since 1998 by research institutes within the scope of the legislation prepared in Türkiye. The first field trials of transgenic plants in our country began in 1999 by the Çukurova Agricultural Research Institute for corn and cotton, the Potato Research Institute for potato, the Cotton Research Institute and Harran Agricultural Research Institute for cotton. In these field trials, the necessary procedures are carried out for the risk analysis and risk assessment. In addition, the necessary analyses to determine the food equivalence are carried out in a laboratory environment. The features found in transgenic plants in field trials are known as resistance to corn stalk and stem borers in corn, resistant to both herbicide and pink and cotton bollworms in cotton, and Colorado potato beetle in potatoes (Demir *et al.* 2006).

### 2.2.1. *Some Potential Risks or Harms of Genetically Modified Organisms*

Genetically modified plants are obtained by using recombinant DNA technologies developed with today's technology in order to meet the food needs of people as a result of the rapid increase in the world population. It is considered that these new genes transferred by recombinant DNA technologies may have potential risks in the future (Arvas & Kocaçalışkan 2020; Haile *et al.* 2020). Today, there are concerns that unwanted gene transfer from commercialized GM crops may increase the pressure on biodiversity and become a potential health problem (Schütte *et al.* 2017; Alamnie & Andualem 2020). It is thought that the experimental data of studies on the potential toxic effects and health risks of GM plants are still not sufficient (Domingo 2016). Some potential risks of GM products can be listed as follows (Saltik 2010):

- Factors that cause new allergies and toxins (toxic substances) may arise in foods.
- With the use of these products, some threats that have not yet been determined may be passed on to the genetic structure of people.
- Increasing use of chemicals in food production can accelerate the pollution of natural resources (such as water and soil).
- Genes in GM crops can be transferred also to other plants over time. For example, the weeds unaffected by herbicides may have the potential to invade agricultural fields when considering a gene transferred to weeds.
- As a result of gene transfer, disease barriers between the species may be broken over time. In other words, a disease that is not a threat to one species may become a threat to another species as a result of gene transfer.
- Biodiversity in crops may be lost.
- As living things are artificially brought in new features by biotechnological methods, their inevitable side effects may occur over time. As a result, the ecological balance may be damaged.

Some potential risks that may occur in humans as a result of the use of genetically modified products can be listed as follows:

**a. Allergic effects:** It is one of the most common effects known. The human body may show allergic reactions to proteins that it does not recognize. As a result, depending on individual sensitivity, the results that may lead to death may occur. It has been determined that soy allergies have increased by approximately 50% as a result of the use of genetically modified soybean in the UK (Smith 2007).

Conner *et al.* (2003) reported that it had immunological effects, including allergic hypersensitivity, in corn plant genetically modified to produce Bt endotoxin. Various allergic reactions have been observed in agricultural workers collecting various products containing Bt toxin. It has been reported that this occurs as a result of inhaling the pollen of products containing Bt toxin (Bernstein *et al.* 2003).

**b. Toxic effects:** In some genetically modified plants, the weed and insecticidal genes and terminator genes show their effects by producing toxins. As a result, the accumulation of toxins in tissues and cells may pose significant risks. It is not known exactly what effect this situation will have on the excretory organs. In a study, it was stated that the phosphorus and sodium excretion in their urine decreased, fatty liver increased as a result of feeding mice with GM corn (MON863) for 90 days; that is, these two excretion organs showed signs of damage. This effect increases in a dose-dependent manner, and it was more severely seen in those who consumed it more (Vazquez 1999). In 1989, it was determined that a genetically engineered type of L-tryptophan caused the death of 37 people and the cause of EMS (Eosinophilia Myalgia Syndrome) disease in 5000 people in the USA. As a result of the use of GM products in studies the findings have shown that the risk of infertility and birth defects increased. In a study conducted by the European Food Safety Authority, it was determined that after the birth of mice fed by genetically modified soybean, the newborn mice were smaller than the others and most of them died within 21 days (Haspolat 2012).

**c. Resistance to antibiotics:** One of the processes performed in gene transfer is the antibiotic resistance. The transgenic cells and tissues are taken into culture in media containing antibiotics after gene transfer. However, it is considered that there are risks in terms of health, as antibiotic resistance may pass on to bacteria in both humans and animals over time (Vasil 1998). According to the reports of the British Medical Association, the antibiotic resistance genes placed in some crops, after planting in the field, and mutant genes in these plants are transmitted to some bacteria through the soil as the GM plants decompose, and it is thought that they can pass to pathogenic microorganisms in the intestines of humans and animals fed with these products (Uzogara 2000).

**d. Cancer risk:** The data obtained in studies on the carcinogenic effects of GMOs raise doubts that there may be an effect in this direction. The DNA taken with food under normal conditions is degraded in our intestines. However, in some foods that contain DNA beyond what we are used to, this process works differently

and these DNAs can remain without structural changes. DNA fragments that do not undergo any structural change pass into the circulatory system without being fully digested in the digestive system. Therefore, it is thought that DNAs that pass into the circulatory system without being digested are likely to pass into both human and animal cells (Hemmer 1997). In a study conducted on 71 pregnant women of different ages in the USA, it was reported that the most commonly used herbicide (glyphosate) on the world caused a shorter gestation period than the normal pregnancy period as a result of its accumulation in the foods consumed (Parvez *et al.* 2018).

**e. Unknown fears:** The possibility of releasing harmful microorganisms, the toxic substances that threaten human and animal health as a result of some accidents that may occur during biotechnology laboratory studies is one of these fears (Uzogara 2000).

### **2.2.2. Some Potential Benefits of Genetically Modified Organisms**

**a. Effects of crops on the shelf life:** Keeping the genes responsible for the production of the ethylene hormone, which plays an active role in ripening and rotting in the products, under control the enzyme that destroys the cell wall is suppressed, and pectin degradation is delayed. As a result, the ripening period of vegetables and fruits is delayed and the shelf life of the products is extended. Thus, it is known that the problems that may occur during the transportation or storage process are prevented. For this purpose, the first genetically modified product to be approved in the USA was the tomato variety 'Flavr Savr' (Çelik & Balık 2007).

**b. Use in the treatment of diseases:** In recent years, the gene technology has begun to be used in the treatment of some diseases, albeit less. The soybean containing ovokinin, which has an antihypertensive effect, and lactose-free milk production for individuals with lactose intolerance can be given as examples (Matoba *et al.* 2001; Sang 2003).

**c. Edible vaccine and drug production:** Vaccines are the solutions created from weakened or killed disease agents. The cost of these vaccines is high and have disadvantages such as the requirement for cold storage and some application difficulties. Therefore, with the use of biotechnology, the cost-effective, storage-free, easily dispersible even edible vaccines have begun to be produced. These types of vaccines are prepared in a way that contains antigens but not the other genes that can cause pathogenicity (Mishra *et al.* 2008). The broccoli to enrich its antioxidant content; tea for enrichment with flavonoids;

potato, banana and tomato plants can be genetically modified to store vaccines. Some tropical products, such as bananas, that are consumed raw when ripe, can be genetically modified to produce proteins that can be used against intestinal infections such as hepatitis, rabies, dysentery, cholera and diarrhea, which are common in developing countries (Uzogara 2000).

**d. Resistance to insecticides:** Insect-resistant plants were obtained by transferring a gene of *Bacillus thuringiensis* (Bt), which has insecticidal potential to some plants such as potato, soybean and corn. *B. thuringiensis* protein is a toxic to insects such as Colorado potato beetle and corn borers, and is broken down by the stomach acid (Uzogara 2000). Again, the endotoxin gene in *Bacillus thuringiensis*, which provides resistance to Lepidoptera family, is especially effective against the larvae that are a problem in corn and cotton cultivation (Çetiner 2005). Bringing this feature to plants will not only eliminate the need for insecticides, but also prevent damage to insects such as non-target bees and predators (Hails, 2000; Çelik & Balık 2007).

**e. Resistance to herbicides:** Herbicide-resistant GM plants have resistant genes that will not damage the herbicide's effect by inactivating the active ingredient in herbicides. These genes are obtained either through microorganisms or from naturally resistant plants (Demir *et al.* 2006). Dalapon herbicide used in agricultural fields reduces both the yield of plants and the economic value of the soil. However, the development of plants resistant to dalapon has been possible with the transfer of dehalogenase genes taken from bacteria by biotechnological methods to the plant. Genetically modified tobacco resistant to dalapon was obtained by transferring genes from *Rhizobium* sp. to tobacco plant using gene technology (Kaya *et al.* 2013).

### 3. Use of Genetically Modified Plants in Agriculture and Its Relationship with Sustainable Agriculture

The agricultural biotechnology is the modification of the structure of microorganisms using many scientific tools and techniques such as molecular markers, molecular diagnostics, tissue culture and vaccines. The plant biotechnology is done by transferring one or more desired characteristics such as yield, quality, resistance to diseases, pests and weeds from a crop species to a different plant species (Kar 2019).

Genetically modified plants are divided into three groups as generations. The features such as resistance to herbicides, pests and environmental stressors are included in the first generation GM crop group. In the second generation



GM crops the increasing the yield and feeding quality have been taken into consideration. The third generation GM crops are plants that is used in human therapy to produce drugs and vaccines (Fernandez *et al.* 2006). Among these three generations, the first generation GM plants have been the first generation plants that have wide production opportunities around the world. The studies on second and third generation transgenic products are ongoing and it is expected that commercial production of these products will increase in the near future (Özcan 2009).

Today, the production of GM plants is increasing day by day and it is encountered in many areas. The most common products are soybean, cotton, corn and canola, and the most applications for this purpose were made in soybean. In addition to these; the rice, pumpkin, sunflower, peanut, cassava and papaya are also produced as GM crops; and the works continue on banana, raspberry, strawberry, cherry, pineapple, pepper, melon and watermelon (Çiçekçi 2008; Cebirbay & Aktaş 2018; Babiye *et al.* 2020). In general, the uses of GM crops in agriculture are as follows (Haspolat 2007; Cebirbay & Aktaş 2018):

- To reduce the use of chemical inputs (such as pesticides, chemical fertilizers) in agriculture.
- To increase the yield and quality of agricultural products, to improve their aroma and appearance.
- To increase the resistance of plants against diseases, pests and weeds.
- To get more efficiency from the unit area.

Table (2 and 3) are shown genetically modified organisms are used in which product and for what purpose.

Table 2. Genetically modified cereals (Demir *et al.* 2006; Ergin & Yaman 2013; Hilscher *et al.* 2017; ISAAA 2017; Tsatsakis *et al.* 2017; Cebirbay & Aktaş 2018; Babiye *et al.* 2020)

GM products	Goals
Rice	Increase yield, iron and beta-carotene ratio
Rice, walnut	Reducing allergic effects
Rice	Increasing the amount of vitamin A
Corn and soybean	Resistance to herbicides, use in fish feeding
Cotton and corn	Resistance to insecticides
Wheat	Resistance to powdery mildew
Corn	Resistance to plant virus diseases and use in broiler feeding

Table 3. GM fruit and vegetables (Demir *et al.* 2006; Ergin & Yaman 2013; Hilscher *et al.* 2017; ISAAA 2017; Arvas *et al.* 2018; Cebirbay & Aktaş 2018)

GM crops	Goals
Tomato	Resistance to herbicides and extending shelf life, increasing the rate of carotenoids
Banana	Resistance to banana bacterial-xanthomonas wilt (BXW)
Potato	Increasing protein amount and stress tolerance
Potato, tomato	Reducing the amount of toxic substances
Grape, pepper, tomato	Seedless crop production
Soybean, corn, potato	Resistance to antibiotics and insecticides
Canola, sunflower	Increasing the unsaturated fat rate, resistance to herbicides
Strawberry, peach, ananas	Delaying the ripening time and extending the shelf life
Potato	Prevention of cholera and diarrhea
Banana	Resistance to viruses
Papaya, potato	Resistance to viruses
Apple	Inhibition of enzymatic browning

The basis of sustainable agriculture is the protection of soil, water, energy and the environment, ensuring its continuity, the reusability of these resources and the principle of not being polluted. The sustainable agriculture basically has to create a balance between the resource conservation and environmental protection, minimum workforce, input use and optimum productivity (Açıksöz 2001).

Sustainable agricultural techniques used in the production of herbal products include tillage, weed control, crop rotation, seed selection, planting, fertilization, maintenance, harvesting and threshing processes. In each of these listed stages, it is among the main objectives of the producers to achieve high efficiency by using the least input. At the same time, the farmers are successful in these processes when they choose the right and appropriate agricultural systems in their own ecology. They do not only spoil the natural resources they use in production but also not pollute. Undoubtedly, many factors such as the ecological factors of the region, the socio-economic level of the producer, the agricultural culture reached, purchasing power, agricultural extension and consultancy support, land ownership, and marketing opportunities affect all of these (Ulukan & Güler 2000).

The sustainable agriculture combines three main goals. These are the principles of environmental health, economic profitability and social equality (Chernyak 2001). The sustainability in agricultural lands is aimed with the conscious use of soil, air and water in terms of the environment. It is important that people who are economically engaged in agriculture earn the necessary income from their products both in the short and long terms. In terms of social aspects, the sustainable agriculture should be in accordance with the regional moral values (Türkmen 2007).

A sustainable agriculture model that includes genotype, environment, management and human factors can be applied to solve complex agricultural problems. Therefore, the factors such as suitable plant varieties, genetic characteristics of plant seeds, resistance to diseases, tolerance to drought, resistance of plants to acid and alkali soil conditions are important in sustainable agriculture. Secondly, the role of the environment, temperature, altitude, precipitation amount and time, sunshine duration, day length, soil acidity (pH) and other soil characteristics are significant. Thirdly, the features such as agricultural management, crop rotation, tillage, integrated pest and weed control are important. In addition, the cultural and social status of the producers must be taken into account when the human factor is taken into account in sustainable agriculture (Türkmen 2007).

In the light of these explanations, creating a sustainable agricultural sector will be possible by ensuring the food safety, increasing crop production, productivity and quality. In order to meet the nutritional needs with the increase in the world population, it is necessary to increase the production and export by increasing the production of the plants that have a comparative advantage, to increase the income of the farmers and to achieve the objectives of ensuring stability. Therefore, it is of great importance to use environmentally friendly products and production technologies with the protection of natural resource stock in agricultural production, and more environmentally friendly agricultural systems such as good agricultural practices and organic agriculture (Turhan 2005).

The biotechnological possibilities reached today have made it possible to change the genetic material of organisms in order to gain new characteristics to plants, animals and bacteria (Öcal & Işıklı 2019). In order to develop bacterial-origin toxin-producing varieties, the transferring resistant genes to some plants may cause unwanted genes to be transmitted to nature, which may lead to disruption of the ecological balance. When nature is carefully examined, it is known that there is a gene exchange between the species. Therefore, it can be

said that the gene flow from GM crops to their wild relatives is possible (Aslan & Şengelen 2010). It is considered that GM crops may reduce biodiversity as well as contain allergic substances due to the activation of new genes in plants (Krimsky 2019). The genes in genetically modified plants can also be passed on to wild types in undesirable ways, such as seeds or pollen. It has been reported that some GM plants in the USA can fertilize wild plants more than 20 km away through their pollen, as well as transfer their genetic characteristics to another plant (Bravo & Soberon 2007).

#### 4. Discussion and Conclusion

Today, the biotechnology is used in many fields such as agriculture, medicine, veterinary medicine, pharmacy and industry. It is inevitable to use biotechnological methods in agriculture in order to maintain the genetic diversity of plants in order to meet the food needs of the rapidly increasing world population and to complete the use of new methods in breeding studies in a shorter time. The promising studies on yield and quality increase in plant production, increasing resistance to adverse climatic conditions, extending the shelf life of products and increasing the plant resistance against diseases and pests, which are one of the biggest problems of modern agriculture, highlight gene technology. These studies clearly demonstrate the importance of gene technology in terms of ensuring the sustainability in agriculture. The use of biotechnological methods emerges as a necessity in order to ensure the sustainability of economic and natural resources within the framework of sustainable agriculture. However, it is a matter of debate how genes transferred using biotechnological methods can change over time. Considering the possible risks, it may not be possible to compensate for the negative effects on the ecological balance, human and environmental health. This is a matter of debate as it contradicts the principle of establishing a balanced agriculture system based on the principle of economic profitability, environmental factors and social equality, which are among the objectives of sustainable agriculture. As a result, the integration of gene technology into sustainable agriculture today both supports and challenges.

#### References

- Açıksöz S (2001). Ankara'da Kentsel Tarım Kapsamında Atatürk Orman Çiftliği'nin Günümüz Koşullarında Yeniden Değerlendirilmesi Üzerinde Bir Araştırma. Ankara Üniversitesi. Fen Bilimleri Enstitüsü. Doktora Tezi. Ankara.

- Alamnie G & Andualem B (2020). Biosafety Issues of Unintended Horizontal Transfer of Recombinant DNA. In Genetic Transformation in Crops.
- Arvas Y E; Aksoy H M & Yılmaz K (2018). Patates Bitkisinde Biyoteknolojik Çalışmalar. International Journal of Life Sciences and Biotechnology 1(1): 37-47.
- Arvas Y E & Kocaçalışkan İ (2020). Genetiği Değiştirilmiş Bitkilerin Biyogüvenlik Riskleri. Türk Doğa ve Fen Dergisi 9(2): 201-210.
- Arvas Y E & Yılmaz K (2019). Genetiği Değiştirilmiş Bitkilerin Biyolojik Çeşitliliğe Potansiyel Etkileri. Yüzüncü Yıl Üniversitesi Tarım Bilimleri Dergisi 29(1): 168-177.
- Aslan D & Şengelen M (2010). Farklı Boyutlarıyla Genetiği Değiştirilmiş Organizmalar. ISBN: 978-605-5867-26-3. Ankara.
- Atış E (2004). Çevre ve Sürdürülebilir Boyutlarıyla Organik Tarım. Buğday Dergisi, 2004-2005, İstanbul.
- Atsan T & Kaya T E (2008). Genetiği değiştirilmiş organizmaların (GDO) tarım ve insan sağlığı üzerine etkileri. Uludağ Üniversitesi Ziraat Fakültesi Dergisi 22(2): 1-6.
- Babiye B; Haile G & Adamu M (2020). Major Achievements of Plant Biotechnology in Crop Improvements. American Journal of Life Sciences 8(5): 102-106.
- Bawa A S & Anilakumar K R (2013). Genetically modified foods: safety, risk and public concerns a review. Journal of Food Science and Technology 50: 1035-1046.
- Bernstein J A; Bernstein I L; Bucchini L; Goldman L R; Hamilton R G; Lehrer S & Sampson H A (2003). Clinical and laboratory investigation of allergy to genetically modified foods. Environmental health perspectives 111(8): 1114-1121.
- Bravo A; Gill S S & Soberon M (2007). Mode of action of Bacillus thuringiensis Cry and Cyt toxins and their potential for insect control. Toxicon 49(4): 423-435.
- Cebirbay M A & Aktaş N (2018). Genetiği değiştirilmiş organizmalar (GDO) ve etkileri. Gastronomide Güncel Konular, Edition: 1st, Publisher: Billur Yayınevi, 309-325.
- Chernyak V (2001). Sürdürülebilir Tarım ve Kırsal Kalkınmanın Teşvik Hakkında Rapor, On sekizinci Keipa Genel Kurulu.
- Cirik N; Duru E & Joiya A (2017). Herbisite Dirençli Transgenik Patates Çeşitlerinin Geliştirilmesinde Seleksiyon Amacıyla Kullanılan Glufosinat

- Amonyumun Optimum Konsantrasyonunun Belirlenmesi. 7. Ulusal Tarım Öğrenci Kongresi, Selçuk Üniversitesi, Konya.
- Conner A J; Glare T R & Nap J P (2003). There lease of Genetically Modified Crops in to the environment. *The Plant Journal* 33(1): 19-46.
- Craig W; Tepfer M; Degrassi G & Ripandelli D (2008). An Overview of General Features of Risk Assessments of Genetically Modified Crops. *Euphytica* 164: 853-880.
- Crucefix D (1998). *Organic Agriculture and Sustainable Rural Livelihoods in Developing Countries*, Bristol, UK.
- Çelik V & Turgut B D (2007). Genetiği Değiştirilmiş Organizmalar (GDO). *Erciyes Üniversitesi Fen Bilimleri Enstitüsü Dergisi* 23: 13-23.
- Çiçekçi O (2008). İlköğretim Okullarında Görevli Öğretmenlerin Transgenik Ürünler (GDO) Konusundaki Bilgilerinin ve Görüşlerinin Belirlenmesi. Gazi Üniversitesi Eğitim Bilimleri Enstitüsü Aile Ekonomisi ve Beslenme Eğitimi Anabilim Dalı, Yüksek lisans tezi, Ankara.
- Demir A; Seyis F & Kurt O (2006). Genetik yapısı değiştirilmiş organizmalar: I. Bitkiler. *OMÜ Ziraat Fakültesi Dergisi* 21(2): 249-260.
- Domingo J L (2016). Safety assessment of GM plants: An updated review of the scientific literature. *Food and Chemical Tox.* 95: 12-18.
- Ergin S Ö & Yaman H (2013). Genetiği Değiştirilmiş Gıdalar Ve İnsan Sağlığı Üzerine Etkileri. *Gümüşhane Üniversitesi Sağlık Bilimleri Dergisi* 2(2): 261-274.
- Eryılmaz G A & Kılıç O (2018). Türkiye’de Sürdürülebilir Tarım ve İyi Tarım Uygulamaları. *Tarım ve Doğa Dergisi* 21(4): 624-634.
- Fernandez-Cornejo J & Caswell M (2006). *The First Decade of Genetically Engineered Crops in the United States*, Economic Research Service Economic/USDA, EIB-11.
- Gençler F (2009). AB ve Türkiye’de Sürdürülebilir Tarım Uygulamalarının İncelenmesi ve Türkiye’de Sürdürülebilir Tarıma Yönelik Politikaların Geliştirilmesi Üzerine Bir Araştırma: Zeytin Örneği. Doktora tezi. Ege Ün. Fen Bil. Ens. İzmir.
- Gold M (1999). *Sustainable Agriculture: Definition Sand Terms*. Special reference briefs 99-02, USDA National Agricultural Library (NAL), ISSN 1052-5368.
- Hail G; Adamu M; Tekle T & Sanusi A (2020). The Effects of Genetically Modified Organisms (GMO) on Environment and Molecular Techniques to Minimize Its Risk. *American Journal of Polymer Science and Technology* 6(4): 32-39.

- Hails R S (2000). Genetically modified plants—the debate continues. *Trends in Ecology & Evolution* 15(1): 14-18.
- Haspolat I (2007). The Trade of Genetically Modified Agricultural Crops. *Gazi Univ J Vocational Edu* 9: 58-75.
- Haspolat I (2012). Genetiği Değiştirilmiş Organizmalar ve Biyogüvenlik. *Ankara Üniv Vet. Fak. Derg.* 59: 75-80.
- Hemmer W (1997). Foods derived from genetically modified organisms and detection methods (pp. 1-3). Basel: Agency BATS.
- Hilscher J; Burstmayr H; & Stoger E (2017). Targeted modification of plant genomes for precision crop breeding. *Biotechnology journal*, 12(1): 1600173.
- ISAAA (2017). Global Status of Commercialized Biotech/GM Crops in 2017: Biotech Crop Adoption Surges as Economic Benefits Accumulate in 22 years. ISAAA brief 53: 25-26.
- İnce H Ö; Bahadıroğlu C; Toroğlu S & Bozdoğan H (2013). Genetiği Değiştirilmiş Mısır Bitkisinin Zararlı Lepidopterlere Karşı Direnci Üzerine Değerlendirmeler. *Nevşehir Bilim ve Teknoloji Der.* 2(1): 78-89.
- Kar B (2019). Modern Tarımsal Biyoteknoloji Alanları ve Faydaları. *Ejons Internat. Jour. on Mathematics, Engineering-Natural Sciences*, 12p. [https://www.ejons.co.uk/Makaleler/1063474001\\_%c4%b0lk%20sayfa%2012-2.pdf](https://www.ejons.co.uk/Makaleler/1063474001_%c4%b0lk%20sayfa%2012-2.pdf). Accessed: 25.05.2021.
- Karaca C (2013). Türkiye’de Sürdürülebilir Tarım Politikaları: Tarım Sektöründe Atıl ve Yenilenebilir Enerji Kaynakların Değerlendirilmesi. *Tarım Ekonomisi Dergisi* 19(1): 1-11.
- Kaya Y; Maraklı S; Gozukirmizi N; Mohamed E; Javed M & Huyop F (2013). Herbicide tolerance genes derived from bacteria. *The Journal of Animal and Plant Sciences* 23(1): 85-91.
- Klümper W & Qaim M (2014). A meta-analysis of the impacts of genetically modified crops. *PloS one* 9(11), e11162.
- Krimsky S (2019). *GMOs Decoded: A Skeptic’s View of Genetically Modified Foods*. MIT Press.
- Kulaç İ & Ağirdil Y (2006). Sofralarımızdaki tatlı dert, genetiği değiştirilmiş ile halk sağlığına etkileri. *Türk Biyokimya Dergisi* 31(3): 151-155.
- Matoba N; Doyama N; Yamada Y; Maruyama N; Utsumi S & Yoshikawa M (2001). Design and Production of Genetically Modified Soybean protein with anti-hypertensive activity by incorporating potent analogue fovokinin (2-7). *FEBS Letters* 497: 50-54.



- Mishra N; Gupta P N; Khatri K; Goyal A K & Vyas S P (2008). Edible Vaccines: A New Approach to Oral Immunization. *Indian Journal of Biotechnology* 7: 283-294.
- Öcal E E & Işıklı B (2019). Genetiği Değiştirilmiş Organizmalar Yararlı Mı, Zararlı Mı? *Genetically Modified Organisms: Useful or Harmful? Estüdam Halk Sağlığı Dergisi* 4(1): 71-79.
- Özcan S (2009). Modern Dünyanın Vazgeçilmez Bitkisi Mısır: Genetiği Değiştirilmiş (Transgenik) Mısırın Tarımsal Üretime Katkısı, *Türk Bilimsel Derlemeler Dergisi* 2: 1-34.
- Parvez S; Gerona R; Proctor C; Friesen M; Ashby J; Reiter J & Winchester P (2018). Glyphosate Exposure in Pregnancy and Shortened Gestational Length: A Prospective Indiana Birth Cohort Study. *Environmental Health* 17(1): 1-12.
- Pengue W A (2016). Cultivos transgénicos, Hacia dónde fuimos? Veinte años después: *Lasoja en Argentina 1996-2016*.
- Perlas N (1993). *Seven Dimensions of Sustainable Agriculture*, Manila: CADI.
- Pezikoğlu F (2006). Türkiye’de Sürdürülebilir Tarım Uygulamaları ve Yönlendirilmesi İçin Gerekli Politikaların Belirlenmesi. *Doktora tezi. Uludağ Üniversitesi. Fen Bilimleri Ens. Bursa*.
- Rigby D & Bown S (2003). *Organic Food and Global Trade: Is the market delivering agricultural sustainability*. University of Manchester, School of Economic Studies. Discussion Paper Series, No: 0326.25.
- Saltık A (2010). Genetiği Değiştirilmiş Gıdalar ve Halk Sağlığı. *Der. Dilek Aslan-Meltem Şengelen, Farklı Boyutlarıyla Genetiği*.
- Sang H (2003). Genetically Modified Live Stock and Poultry and Their Potential Effects on Human Health and Nutrition. *Trends in Food Science & Technology* 14(5): 253-263.
- Schütte G; Eckerstorfer M; Rastelli V; Reichenbecher W; Restrepo V S; Ruohonen L M & Mertens M (2017). Herbicide resistance and biodiversity: agronomic and environmental aspects of genetically modified herbicide-resistant plants. *Environmental Sci. Eur.* 29(1): 1-12.
- Smith M J (2007). Point of view: Genetically Modified Food unsafe? Evidence that links GM Foods to allergic responses mounts. *Genetic Engineering News* 27(19): 1-4.
- Stewart C N; Richards H A & Halfhill M D (2000). *Transgenic Plants and Biosafety: Science, Misconceptions and Public Perceptions*, *Biotechniques* 29: 823-843.

- Şen S & Altınkaynak S (2014). Genetiği değiştirilmiş gıdalar ve potansiyel sağlık riskleri. *Sakarya Üniversitesi Fen Bilimleri Enstitüsü Dergisi* 18(1): 31-38
- Teksöz G (2014). Geçmişten ders almak: Sürdürülebilir kalkınma için eğitim. *Boğaziçi Üniversitesi Eğitim Dergisi* 31(2): 73-97.
- Tıraş H H (2012). Sürdürülebilir Kalkınma ve Çevre: Teorik Bir İnceleme. *Kahramanmaraş Sütçü İmam Üniversitesi İktisadi ve İdari Bilimler Fakültesi Dergisi* 2(2): 57-73.
- Tsatsakis A M; Nawaz M A; Tutelyan V A; Golokhvast K S; Kalantzi O I; Chung D H & Chung G (2017). Impact on environment, ecosystem, diversity and health from culturing and using GMOs as feed and food. *Food and Chemical Toxicology* 107: 108-121.
- Tukelman E Ö (2017). Genetiği Değiştirilmiş Ürünlere Karşı Üreticilerin Farkındalıkları. Doktora Tezi. Namık Kemal Üniversitesi. Fen Bilimleri Enstitüsü. Tekirdağ.
- Turhan Ş (2005). Tarımda Sürdürülebilirlik ve Organik Tarım. *Tarım Ekonomisi Dergisi* 11(1): 13-24.
- Türkmen İ (2007). Sürdürülebilir Tarım İçin Yöneylem Araştırması Modeller. Yüksek Lisans Tezi. Çukurova Üniversitesi. Fen Bilimleri Enstitüsü, Adana.
- Ujhelyi G; Vajda B; Béki E; Neszlényi K; Jakab J; Jánosi A; Némédi E & Gelencsér E (2008). Surveying the RR soy content of commercially available food products in Hungary. *Food Control* 19, 967-973.
- Ulukan G & Güler M (2000). GAP Bölgesinde Sürdürülebilir Tarım Açısından Tarla Tarımının Önemi ve Uygulanabilirliği, T.C. Harran Üniversitesi, GAP Çevre Kongresi, Şanlıurfa.
- Uzogara S G (2000). The Impact of Genetic Modification of Human Foods in the 21st Century. *Biotechnology Advances* 18: 179-206.
- Vasil I K (1998). Agriculture: Biotechnology and food security for the 21st century: A real-world perspective. *Nature Biotechnology* 16(5): 399-400.
- Vazquez-Padron R I; Moreno-Fierros L; Neri-Bazán L; Gustavo A; & Lopez-Revilla R (1999). Intragastric and intraperitoneal administration of Cry1Ac protoxin from *Bacillus thuringiensis* induces systemic and mucosal antibody responses in mice. *Life Sciences* 64(21), 1897-1912.
- Yeşil M (2016). Doğa Koruma Yaklaşımlarındaki Değişimlerin Dünyada ve Türkiye'deki Tarihsel Süreci. *Türk Tarım-Gıda Bilim ve Teknoloji Dergisi* 4(10): 867-876.

- Yıldırım U & Öner Ş (2003). Sürdürülebilir Kalkınma Yaklaşımının Türkiye'ye Yansımaları: GAP'ta Sürdürülebilir Kalkınma ve Yerel Gündem 21. Çağdaş Yerel Yönetimler 12(4): 6-27.
- Zimny T; Sowa S; Tyczewska A & Twardowski T (2019). Certain new plant breeding techniques and their marketability in the context of EU GMO legislation–recent developments. *New Biotechnology* 51, 49-56.



# CHAPTER 14

## MODELLING OF DEPENDENCY STRUCTURE AMONG REPEATED MEASUREMENT USING SAS'S PROC MIXED PROCEDURES

Gazel SER

(Assoc. Prof.), Van Yuzuncu Yil University, Faculty of  
Agriculture, Department of Animal Sciences, Van, Türkiye,

e-mail: gazelser@yyu.edu.tr

 0000-0003-2756-4116

### 1. Introduction

The repeated data are defined as the measurements obtained consecutively from the same individual or unit over time or under different conditions. Thus, the dependent variable consists of consecutive measurements obtained from the same individual(s). The examples of repeated measures are the weight measurements from an animal over time, or skin samples taken from different points of the same animal. Since multiple measurements are obtained in repeated data, it provides researchers with the opportunity to work with measurements with less individuals and larger sample sizes. For example, in a study conducted with 5 individuals,  $n=5 \times 14=70$  measurement values will be obtained at the end of the 14<sup>th</sup> week with weekly measurements taken from each individual. In addition, it can provide detailed information about the individual changes of each individual in the study according to the general average. In this sense, it is widely used in many fields, especially in animal production. However, in repeated measures, these measurements taken consecutively from the same individual (same animal) are not independent of each other. Therefore, since the presumption of independence of observations cannot be provided in many classical methods (for example, the analysis of variance), these methods cannot be used in repeated measures. Therefore, the statistical methods which take into account this dependency have been developed (Littell *et al.* 2000; Wang & Goonewardene 2004).

It is possible to define the dependence of observations as the covariance structure of data set in repeated measures. The covariance structures differ according to the design of the experiment or the nature of observations. For this dependency structure to be determined correctly, first of all, the statistical method(s) to be used should allow the definition of different covariance structures. If the covariance structure of the dependent variable cannot be determined correctly, it is likely to an underestimation of the standard error due to the increasing of the type I error rate. However, in an uncomplicated repeated experiment, if the covariance structure is chosen too complex, then the power and effectiveness of the test will also decrease (Hanford 2005). The variance-covariance structures used to determine the relationship structures between the repeated measures are under two headings as; homogeneous and heterogeneous (Kaps & Lamberson 2004).

Various methods are used to evaluate the data obtained from repeated measures. These methods are univariate repeated measures analysis of variance (RANOVA) and multivariate repeated measures analysis of variance (RMANOVA) as classical methods under the assumption of continuous and normal distribution of the dependent variable. However, these classical approaches have some limitations regarding covariance structures. For example, the RANOVA method assumes that the correlation between all pairs of measurements obtained from the same individual is equal, regardless of the distance between the measurement times from which the dependent variable is taken. The method assumes compound symmetry (CS) structure based on the assumption that the measurements obtained from time intervals have homogeneous covariance. Similarly, the RMANOVA assumes that variances and covariances between the measurements obtained over time, known as the Unstructured (UN) covariance structure, are not equal in the relationship structure between the measurements that is; they exhibit a heterogeneous structure. Another important limitation in classical approaches is that they require a balanced data structure. Both the constraints in covariance structures and the requirement for balanced data are not particularly suitable for long-term repeated measurement (Hedeker & Gibbons 2006). Contrary to classical methods, the modern methods such as the general linear mixed model are more preferred than classical methods, as they provide advantages such as being applicable in case of missing observations and defining different covariance structures in the model, which takes into account the repeated measurement structure (Wang & Goonewardene 2004; Davidian 2007). However, since there is no necessity to take the same number of measurements from individuals in general linear mixed models, the individuals

with missing observations are included in the analysis for increasing the power of test (Bati 2017). In mixed models, how each individual changes according to the population mean can be obtained by the random effects defined in the model. Therefore, in mixed models, it is possible to monitor the change and development of individuals over time according to the average (Ser 2012).

This chapter aims to give information about the general linear mixed model and variance-covariance structures used in the analysis of repeated measures data. Thus, the chapter begins with the introduction of the general linear mixed model and variance-covariance structures, respectively. Then, the information is given about the fit criteria used to determine the covariance structure between the repeated measurements. The chapter ends with the applications of SAS software for the selection of variance-covariance structures in the general linear mixed model.

## 2. General Linear Model and General Linear Mixed Model

While the aim in the general linear model ( $Y = X\beta + e$ ) is to model the mean vector structure of the dependent variable ( $\beta$ ) using the parameter vector, the general linear mixed model ( $Y = X\beta + Zu + e$ ) aims to model the covariance matrix structure of the vector of the dependent variable by chance terms based on the ( $u$ ) vector (İyit & Genç 2011). The matrix representation of the general linear model is presented below.

$$\begin{array}{c}
 \begin{bmatrix} y_1 \\ y_2 \\ \cdot \\ \cdot \\ \cdot \\ y_n \end{bmatrix} = \begin{bmatrix} x_{11} & x_{12} & \dots & x_{1p} \\ x_{21} & x_{22} & \dots & x_{2p} \\ \cdot & \cdot & \dots & \cdot \\ \cdot & \cdot & \dots & \cdot \\ \cdot & \cdot & \dots & \cdot \\ x_{n1} & x_{n2} & \dots & x_{np} \end{bmatrix} \begin{bmatrix} \beta_1 \\ \beta_2 \\ \cdot \\ \beta_p \end{bmatrix} + \begin{bmatrix} e_1 \\ e_2 \\ \cdot \\ \cdot \\ \cdot \\ e_n \end{bmatrix} \\
 \underbrace{\hspace{10em}}_{Y} \quad \underbrace{\hspace{10em}}_{X\beta} \quad \underbrace{\hspace{10em}}_{e}
 \end{array}$$

In matrix notation,  $\beta_1, \beta_2, \dots, \beta_p$  is the parameter vector for fixed effects (eg t1, trt2, ..., trtp) and  $e$  is the random error vector ( $N\sim(0, \sigma_e^2)$ ). However,  $Y$  is the response vector and  $X$  is the design matrix for fixed effects. Thus, the statistical model of the fixed-effect general linear model;  $Y = X\beta + e$  ( $E(Y) = X\beta$ ,  $V(Y) = \sigma^2 I$ ,  $Y \sim N(X\beta, I\sigma_e^2)$ ).



In the general linear mixed model developed on the basis of the general linear model, random effects are added to the model as well as fixed effects. Matrix representations are given below.

$$\begin{matrix} \begin{bmatrix} y_1 \\ y_2 \\ \vdots \\ y_n \end{bmatrix} \\ \underbrace{\hspace{10em}} \\ Y \end{matrix} = \begin{matrix} \begin{bmatrix} x_{11} & x_{12} & \dots & x_{1p} \\ x_{21} & x_{22} & \dots & x_{2p} \\ \vdots & \vdots & \dots & \vdots \\ x_{n1} & x_{n2} & \dots & x_{np} \end{bmatrix} \\ \underbrace{\hspace{10em}} \\ X\beta \end{matrix} \begin{matrix} \begin{bmatrix} \beta_1 \\ \beta_2 \\ \vdots \\ \beta_p \end{bmatrix} \\ + \end{matrix} \begin{matrix} \begin{bmatrix} z_{11} & z_{12} & \dots & z_{1p} \\ z_{21} & z_{22} & \dots & z_{2p} \\ \vdots & \vdots & \dots & \vdots \\ z_{n1} & z_{n2} & \dots & z_{np} \end{bmatrix} \\ \underbrace{\hspace{10em}} \\ Zu \end{matrix} \begin{matrix} \begin{bmatrix} u_{11} \\ u_{21} \\ \vdots \\ u_{nq} \end{bmatrix} \\ + \end{matrix} \begin{matrix} \begin{bmatrix} e_1 \\ e_2 \\ \vdots \\ e_n \end{bmatrix} \\ \underbrace{\hspace{10em}} \\ e \end{matrix}$$

The term mixed is used because the general linear mixed model includes both fixed effects ( $\beta$ ) and random effects ( $u$ ). Accordingly, the statistical model of the general linear mixed model is given in Equation 1.

$$Y = X\beta + Zu + e \tag{1}$$

In Equation 1, it is assumed that the  $Y$ 's are normally distributed and the regression parameter ( $\beta$ ) is constant for all individuals. It is assumed that the random effects ( $u$ ) in the model as the subject specific regression coefficient are independent of each other ( $u \sim N(0, G)$ ). Included in the model are the design matrices for fixed  $X(n \times p)$  and  $Z(n \times q)$  random effects, respectively.  $e$  is the random error term ( $e \sim N(0, R)$ ). Under the assumption that the

random effects are normally distributed;  $E \begin{bmatrix} u \\ e \end{bmatrix} = \begin{bmatrix} 0 \\ 0 \end{bmatrix}$  and  $Var \begin{bmatrix} u \\ e \end{bmatrix} = \begin{bmatrix} G & 0 \\ 0 & R \end{bmatrix}$

Thus, the equation  $V(Y) = V = ZGZ' + R$  is obtained. Because;  $V(Y) = V(X + Zu + e) = V(Zu) + V(e) = ZV(u)Z' + R = ZGZ' + R$  (Wang & Goonewardene 2004; Hedeker & Gibbons 2006; Cue 2021).

## 2. Variance-Covariance Structures Commonly Used in Repeated Measures

In experimental design with repeated measures, the variance-covariance structures are used to determine the relationship between the measurements. These structures are examined under two headings as homogeneous and heterogeneous (Kaps & Lamberson 2004). Some homogeneous aeterogeneous structures frequently used in studies are given in Tables 1 and 2, respectively.

**Table 1.** Some homogeneous covariance structures (Littell et al. 2000; Wang & Goonewardene 2004)

Variance Component, VC	$\begin{bmatrix} \sigma^2 & 0 & 0 & 0 \\ 0 & \sigma^2 & 0 & 0 \\ 0 & 0 & \sigma^2 & 0 \\ 0 & 0 & 0 & \sigma^2 \end{bmatrix}$	<p><i>It is based on the assumption that measurements taken from the same individual have independent and homogeneous variance</i></p>
Compound Symmetry, CS	$\begin{bmatrix} \sigma^2 + \sigma_u^2 & \sigma_u^2 & \sigma_u^2 & \sigma_u^2 \\ \sigma_u^2 & \sigma^2 + \sigma_u^2 & \sigma_u^2 & \sigma_u^2 \\ \sigma_u^2 & \sigma_u^2 & \sigma^2 + \sigma_u^2 & \sigma_u^2 \\ \sigma_u^2 & \sigma_u^2 & \sigma_u^2 & \sigma^2 + \sigma_u^2 \end{bmatrix}$	<p><i>It is based on the assumption that repeated measurements have homogeneous variance-covariance structure and equal correlation between repeated measurement pairs</i></p>
First-Order Autoregressive, AR(1)	$\sigma^2 \begin{bmatrix} 1 & \rho & \rho^2 & \rho^3 \\ \rho & 1 & \rho & \rho^2 \\ \rho^2 & \rho & 1 & \rho \\ \rho^3 & \rho^2 & \rho & 1 \end{bmatrix}$	<p><i>It is based on the assumption that as the distances between repeated measurements increase, the correlation values between them decrease exponentially</i></p>
Toeplitz (TOEP)	$\sigma^2 \begin{bmatrix} 1 & \rho_1 & \rho_2 & \rho_3 \\ \rho_1 & 1 & \rho_1 & \rho_2 \\ \rho_2 & \rho_1 & 1 & \rho_1 \\ \rho_3 & \rho_2 & \rho_1 & 1 \end{bmatrix}$	<p><i>In this structure, it is based on the assumption that repeated measurement pairs with a long time interval between each other have a smaller correlation value than repeated measurement pairs with a closer time interval</i></p>

If variance values vary along the main diagonal in the matrix forms of the covariance structures to be used to determine the relationship structure between the data, such structures are called heterogeneous covariance structures.

**Table 2.** Some Heterogeneous Covariance Structures (Littell *et al.* 2000; Wang & Goonewardene 2004)

Heterogeneous Compound Symmetry, CSH	$\begin{bmatrix} \sigma_1^2 & \sigma_1\sigma_2\rho & \sigma_1\sigma_3\rho & \sigma_1\sigma_4\rho \\ \sigma_2\sigma_1\rho & \sigma_2^2 & \sigma_2\sigma_3\rho & \sigma_2\sigma_4\rho \\ \sigma_3\sigma_1\rho & \sigma_3\sigma_2\rho & \sigma_3^2 & \sigma_3\sigma_4\rho \\ \sigma_4\sigma_1\rho & \sigma_4\sigma_2\rho & \sigma_4\sigma_3\rho & \sigma_4^2 \end{bmatrix}$	It is based on the assumption that repeated measurements have heterogeneous variance and covariance structures.
Heterogeneous First-Order Autoregressive, ARH(1)	$\begin{bmatrix} \sigma_1^2 & \sigma_1\sigma_2\rho & \sigma_1\sigma_3\rho^2 & \sigma_1\sigma_4\rho^3 \\ \sigma_2\sigma_1\rho & \sigma_2^2 & \sigma_2\sigma_3\rho & \sigma_2\sigma_4\rho^2 \\ \sigma_3\sigma_1\rho^2 & \sigma_3\sigma_2\rho & \sigma_3^2 & \sigma_3\sigma_4\rho \\ \sigma_4\sigma_1\rho^3 & \sigma_4\sigma_2\rho^2 & \sigma_4\sigma_3\rho & \sigma_4^2 \end{bmatrix}$	Variances in the main diagonal and the covariance values outside the main diagonal are different from each other. Covariance values between repeated measurement pairs decrease exponentially.
Heterogeneous Toeplitz, TOEPH	$\begin{bmatrix} \sigma_1^2 & \sigma_1\sigma_2\rho_1 & \sigma_1\sigma_3\rho_2 & \sigma_1\sigma_4\rho_3 \\ \sigma_2\sigma_1\rho_1 & \sigma_2^2 & \sigma_2\sigma_3\rho_1 & \sigma_2\sigma_4\rho_2 \\ \sigma_3\sigma_1\rho_2 & \sigma_3\sigma_2\rho_1 & \sigma_3^2 & \sigma_3\sigma_4\rho_1 \\ \sigma_4\sigma_1\rho_3 & \sigma_4\sigma_2\rho_2 & \sigma_4\sigma_3\rho_1 & \sigma_4^2 \end{bmatrix}$	In this model, it is widely used in repeated measurement pairs located at equal time distances from each other. It assumes that as the distances in the time intervals increase, the correlation between the measurement pairs decreases.
Unstructured, UN	$\begin{bmatrix} \sigma_1^2 & & & & \\ & \sigma_{21} & & & \\ & & \sigma_{32} & & \\ & & & \sigma_{43} & \\ & & & & \sigma_4^2 \end{bmatrix}$	Variances and covariances are not equal to each other. This covariance model is suitable when the number of measurements is small and the data set is balanced.

**2.1. Selection of the appropriate covariance structure between repeated measurements**

In general linear mixed models, Akaike (Akaike’s Information Criterion (AIC)), Corrected Akaike’s Information Criterion (AICC) and Bayesian (Bayesian Information Criterion (BIC)) information criteria are frequently used to determine the covariance structure of the dependent variable between the consecutive measures. In the selection of homogenous and heterogeneous variance-covariance structures, the structure providing the smallest AIC, AICC and BIC values is determined as the covariance structure. Then, the results obtained from this structure in the researches are included in the studies (Wang & Goonewardene 2004). The general information on these compliance criteria is given in Table 3.

**Table 3.** Goodness-of-fit criteria used to determine the covariance structure

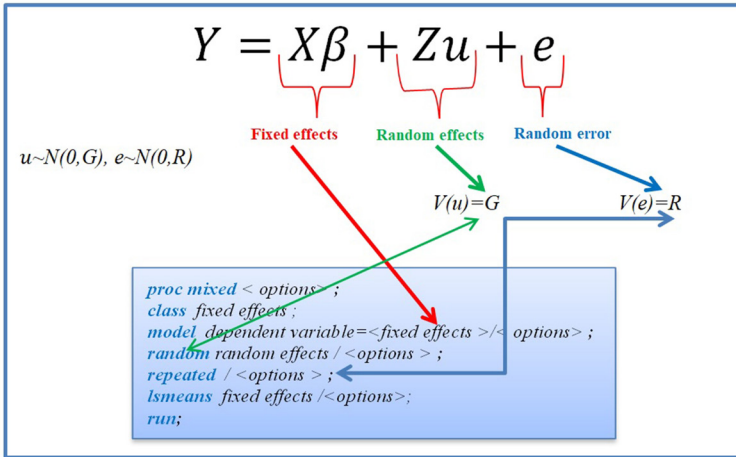
	Equations	References	Selection criteria
AIC	$AIC = -2 \ln(L) + 2k$	Akaike (1973)	Small is better
AICC	$AICC = AIC + \frac{2k(k+1)}{n-k-1}$	Sugiura (1978)	Small is better
BIC	$BIC = -2Ln(L) + kLn(n)$	Schwartz (1978)	Small is better

In the big samples, the success of both AIC and BIC criteria is close to each other in determining the most appropriate variance-covariance structure for the data set. In repeated design with small sample size, both number of parameters and sample size should be taken into account for determining the variance-covariance structure. Therefore, use of BIC is recommended for small sample size (Littell *et al.* 2006; Ser 2012;). In determining the variance covariance structure, both BIC and AIC criteria give consistent results. However, the BIC information criterion is more consistent when the model is finite dimensional (parametric), whereas the AIC information criterion is more consistent when the model is infinite dimensional (non-parametric) (Liu & Yang 2011).

**3. Proc Mixed Procedure in SAS Program**

For general linear mixed model analysis, the proc mixed procedure of the SAS software (SAS 2014) has been developed. The procedure is very popular,

especially as it provides more flexibility in modeling the covariance structures for repeated measures data and provides a comprehensive output to the researcher (Kaps & Lamberson 2004). Therefore, in this section, information about the proc mixed procedure is given and the applications are made through examples. The general format of the procedure and some important commands are given below.



Brief information about frequently used commands about the *proc mixed* process is as follows:

***Proc mixed <options>***: The dataset to be analyzed is defined. By default, SAS gives the results obtained from the REML parameter estimation method. However, when the “method=ML” code is added, it can also give the results obtained from maximum likelihood (ML). At the same time, by adding the “covtest” command, the results of the asymptotic standard errors and Wald tests for the covariance parameter are obtained.

***Class***: The fixed effects used in the analysis are defined.

***Model dependent variable=<fixed effects><options>***: It defines constant effects and covariates in the dependent variable and class section. It is also used to define the fixed effects design matrix ( $X$ ). However, if intercept ( $\beta_0$ ) is not included into the design matrix in the options section, the “noint” command is used. The “solution” command can be used if it is desired to obtain detailed parameter estimations regarding the fixed effects.

***Random effects/<options>***: The random effects in the data set are defined. In other words, it is used to define covariates in the design matrix ( $Z$ ) for individual effects. However, the covariance structure ( $G$ ) is defined using the “type=” command in the options section. Here, all homogeneous and heterogeneous

variance-covariance structures can be defined (e.g. type=cs, vc, ar(1), toep, csh, arh1, toeph, un etc.). In addition, the variable from which repeated measurements are taken is defined with the command “subject= or sub=”.

**Repeated /<options>:** The error term (e) is used to describe the variance-covariance structure (R). The repeated effect under this command must be defined under the class command. For example, if sequential measurements are measured over time, there will be a time-repetitive effect. However, different variance-covariance structures (e.g. type=cs, vc, ar(1), toep, csh, arh1, toeph, un etc.) can be defined using the “type=” command in the options section. In addition, the variable from which repeated measurements are taken is defined with the command “subject= or sub=”.

**lsmeans fixed effects <options>:** It gives least squares estimates for fixed effects. In the Options section, there are the “pdiff” command and “adjust=tukey or bonferroni etc.” Significance and comparisons of treatment averages are obtained by adding commands (Stroup *et al.* 2018).

### 3.1. Example

Four different feedings were applied to male lambs. For body weight gain, live weight was recorded. In the experimental design, 10 lambs used in each treatment group, thus totally 40 lambs were included into study. The live weight measurements for each individual were determined at 15-day intervals and a total of 10 measurements were recorded. Thus, the sample size of this experiment ( $n = \text{number of animals} \times \text{measurement time} = 40 \times 10 = 400$ ) was 400.

The SAS software image, which includes the data entry and frequently used codes related to the application data in the proc mixed procedure, is given in Figure 1. In this application, the procedure was followed by using only the repeated code.

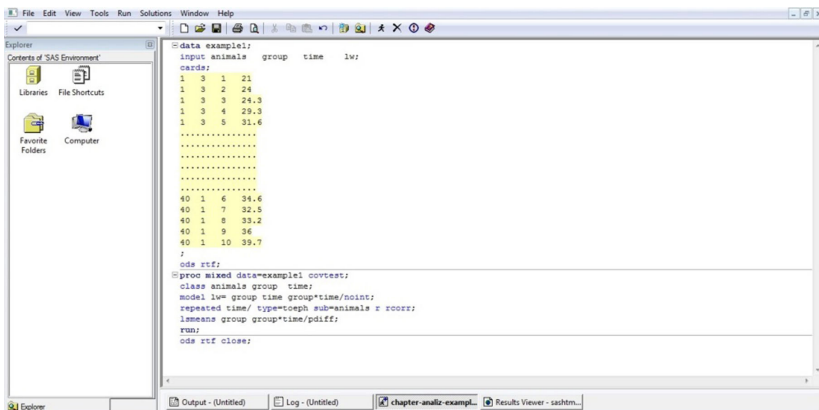


Figure 1. Image of proc mixed procedure in SAS program

### Step 1

In order to determine the relationships between structures of repeated measurements, the variance-covariance structures in Tables 1 and 2 were coded and the goodness fit criteria were obtained. Results are presented as Output 1.

#### SAS Output 1

<i>Homogeneous variance-covariance structures</i>	
<u>repeated time/type=vc</u> sub=animals;	
Fit Statistics	
AIC (Smaller is Better)	2616.0
AICC (Smaller is Better)	2616.0
BIC (Smaller is Better)	2617.6
<u>repeated time/type=cs</u> sub=animals;	
Fit Statistics	
AIC (Smaller is Better)	2015.4
AICC (Smaller is Better)	2015.5
BIC (Smaller is Better)	2018.8
<u>repeated time/type=ar(1)</u> sub=animals;	
Fit Statistics	
AIC (Smaller is Better)	1518.1
AICC (Smaller is Better)	1518.1
BIC (Smaller is Better)	1521.4
<u>repeated time/type=toep</u> sub=animals;	
Fit Statistics	
AIC (Smaller is Better)	1492.8
AICC (Smaller is Better)	1493.4
BIC (Smaller is Better)	1509.7
<i>Heterogeneous variance-covariance structures</i>	
<u>repeated time/type=csh</u> sub=animals;	
Fit Statistics	
AIC (Smaller is Better)	1776.8
AICC (Smaller is Better)	1777.6
BIC (Smaller is Better)	1795.4
<u>repeated time/type=arh(1)</u> sub=animals;	
Fit Statistics	
AIC (Smaller is Better)	1438.3
AICC (Smaller is Better)	1439.7
BIC (Smaller is Better)	1469.6
<u>repeated time/type=toeph</u> sub=animals;	
Fit Statistics	
AIC (Smaller is Better)	1437.5
AICC (Smaller is Better)	1439.1
BIC (Smaller is Better)	1456.9
<u>repeated time/type=un</u> sub=animals;	
Fit Statistics	
AIC (Smaller is Better)	1442.6
AICC (Smaller is Better)	1462.9
BIC (Smaller is Better)	1535.5

**Explanation 1:** The structure that gives the smallest AIC, AICC and BIC values among the covariance structures is determined as the most appropriate structure for the data set. Accordingly; the *toeph* structure, which exhibits a heterogeneous structure, was determined as the most appropriate structure for modeling the relationship between the repeated measurements. In the application, the examples of some basic structures are given. However in the studies, the compatibility of different covariance should be tried as much as possible in determining the covariance suitable for the data set.



### Step 2

After determining suitable of the covariance model for the data set, the results obtained from the *toeph* structure are given in Output 2.

### SAS Output 2

The correlation matrix (R) between pairs of live weight measurements taken over time is given for Animal 1.

Estimated R Correlation Matrix for Animal 1										
Row	Col1	Col2	Col3	Col4	Col5	Col6	Col7	Col8	Col9	Col10
1	1.0000	0.9857	0.9684	0.9510	0.9343	0.9184	0.9011	0.8863	0.8611	0.8315
2	0.9857	1.0000	0.9857	0.9684	0.9510	0.9343	0.9184	0.9011	0.8863	0.8611
3	0.9684	0.9857	1.0000	0.9857	0.9684	0.9510	0.9343	0.9184	0.9011	0.8863
4	0.9510	0.9684	0.9857	1.0000	0.9857	0.9684	0.9510	0.9343	0.9184	0.9011
5	0.9343	0.9510	0.9684	0.9857	1.0000	0.9857	0.9684	0.9510	0.9343	0.9184
6	0.9184	0.9343	0.9510	0.9684	0.9857	1.0000	0.9857	0.9684	0.9510	0.9343
7	0.9011	0.9184	0.9343	0.9510	0.9684	0.9857	1.0000	0.9857	0.9684	0.9510
8	0.8863	0.9011	0.9184	0.9343	0.9510	0.9684	0.9857	1.0000	0.9857	0.9684
9	0.8611	0.8863	0.9011	0.9184	0.9343	0.9510	0.9684	0.9857	1.0000	0.9857
10	0.8315	0.8611	0.8863	0.9011	0.9184	0.9343	0.9510	0.9684	0.9857	1.0000

**Explanation 2:** In the correlation matrix created for Animal 1, the rows and columns show time points at which measurements were taken. In the matrix, the repeated measurement pairs in the far time interval have a smaller correlation value than the repeated measurement pairs with a closer time interval. For example; the correlation (r) between the body weight measurements at the 1<sup>st</sup> and 2<sup>nd</sup> measurement times is 98.57 % while 83.15 % at the 1<sup>st</sup> and 10<sup>th</sup> measurement times.

For *toeph* covariance structure, the covariance parameter estimates and their significances are as follows.

Covariance Parameter Estimates					
Cov Parm	Subject	Estimate	Standard Error	Z Value	Pr >Z
Var(1)	animals	27.9227	6.5530	4.26	<.0001
Var(2)	animals	29.4655	6.8813	4.28	<.0001
Var(3)	animals	37.2321	8.7227	4.27	<.0001
Var(4)	animals	48.5827	11.4014	4.26	<.0001
Var(5)	animals	57.6527	13.5356	4.26	<.0001
Var(6)	animals	70.6534	16.5510	4.27	<.0001
Var(7)	animals	77.7249	18.1223	4.29	<.0001
Var(8)	animals	85.5676	19.8307	4.31	<.0001
Var(9)	animals	98.3272	22.6022	4.35	<.0001
Var(10)	animals	100.14	22.8139	4.39	<.0001
TOEPH(1)	animals	0.9857	0.003381	291.53	<.0001
TOEPH(2)	animals	0.9684	0.007696	125.83	<.0001
TOEPH(3)	animals	0.9510	0.01222	77.80	<.0001
TOEPH(4)	animals	0.9343	0.01683	55.53	<.0001
TOEPH(5)	animals	0.9184	0.02157	42.58	<.0001
TOEPH(6)	animals	0.9011	0.02713	33.22	<.0001
TOEPH(7)	animals	0.8863	0.03317	26.72	<.0001
TOEPH(8)	animals	0.8611	0.04192	20.54	<.0001
TOEPH(9)	animals	0.8315	0.05202	15.98	<.0001

**Explanation 3:** In this model, the different variance estimates are obtained for each time point due to its heterogeneous structure ( $\sigma_1^2, \sigma_2^2, \dots, \sigma_{10}^2$ ). These variances form the diagonal elements of the *toeph* covariance matrix. However, TOEPH(1), TOEPH(2), TOEPH(3), TOEPH(4), TOEPH(5), TOEPH(6), TOEPH(7), TOEPH(8) and TOEPH(9) show the covariance between the measurements of animal 1 in which consecutive measurements were taken. Accordingly, the matrix representation of the *toeph* covariance structure can be formed as follows.

$$R = \begin{bmatrix} 27.9227 & 0.9857 & 0.9684 & 0.9510 & 0.9343 & 0.9184 & 0.9011 & 0.8863 & 0.8611 & 0.8315 \\ 0.9857 & 29.4655 & 0.9857 & 0.9684 & 0.9510 & 0.9343 & 0.9184 & 0.9011 & 0.8863 & 0.8611 \\ 0.9684 & 0.9857 & 37.2321 & 0.9857 & 0.9684 & 0.9510 & 0.9343 & 0.9184 & 0.9011 & 0.8883 \\ 0.9510 & 0.9684 & 0.9857 & 48.5827 & 0.9857 & 0.9684 & 0.9510 & 0.9343 & 0.9184 & 0.9011 \\ 0.9343 & 0.9510 & 0.9684 & 0.9857 & 57.6527 & 0.9857 & 0.9684 & 0.9510 & 0.9343 & 0.9184 \\ 0.9184 & 0.9343 & 0.9510 & 0.9684 & 0.9857 & 70.6534 & 0.9857 & 0.9684 & 0.9510 & 0.9343 \\ 0.9010 & 0.9184 & 0.9343 & 0.9510 & 0.9684 & 0.9857 & 77.7249 & 0.9857 & 0.9684 & 0.9510 \\ 0.8863 & 0.9010 & 0.9184 & 0.9343 & 0.9510 & 0.9684 & 0.9857 & 85.5676 & 0.9857 & 0.9684 \\ 0.8611 & 0.8863 & 0.9010 & 0.9184 & 0.9343 & 0.9510 & 0.9684 & 0.9857 & 98.3272 & 0.9857 \\ 0.8315 & 0.8611 & 0.8863 & 0.9010 & 0.9184 & 0.9343 & 0.9510 & 0.9684 & 0.9857 & 100.14 \end{bmatrix}$$

The results for the fixed effects obtained from the *toeph* structure are given below.

Type 3 Tests of Fixed Effects				
Effect	Num DF	Den DF	F Value	Pr > F
group	3	37	0.06	0.9815
time	9	323	109.70	<.0001
group*time	27	323	1.24	0.1946

**Explanation 4:** When the results for fixed effects are analyzed, the time factor has a significant effect ( $p < 0.0001$ ). In other words, it can be stated that there are significant differences between the live weight measurements depending on time. In addition, it was determined that different feeding methods and interaction effect of these methods over time were not significant.

## Conclusion

In repeated measures, it is first necessary to determine the nature of the relationship between the measures, because the covariance structures used in determining the relationship structure have a significant effect on the predictions

to be made. In determining the covariance structures, many factors should be taken into account, such as both the measurement times in which the consecutive measurements are obtained and the time-dependent changes in the relationship between the pairs of observations. However, the statistical methods to be used in determining the covariance structure are also important. Contrary to the strict attitudes of classical methods on covariance structures, the mixed model approaches that provide flexibility in defining different covariance structures should be preferred.

## References

- Bati C (2017). Tekrarlı Ölçümlü Denemelerde Varyans-Kovaryans Yapısının Belirlenmesinde Parametre Tahmin Yöntemlerinin Değerlendirilmesi. Yüksek Lisans Tezi. Van Yüzüncü Yıl Üniversitesi, Fen Bilimleri Enstitüsü, Zootekni Anabilim Dalı, Van.
- Cue, R.I., 2021. Statistical Methods II AEMA-610. Available at: <http://animsci.agrenv.mcgill.ca/StatisticalMethodsII/index.html>. (Accessed: 08.09.2021)
- Davidian M (2007). ST732 Applied Longitudinal Data Analysis. Available at: <http://www.stat.ncsu.edu/people/davidian/courses/st732/> (Accessed:11.09.2016)
- Hanford K (2005). Stat 892: Mixed Models. Available at: [ftp://tech.obihiro.ac.jp/suzuki/mixed\\_model.pdf](ftp://tech.obihiro.ac.jp/suzuki/mixed_model.pdf) (Accessed: 10.08.2021).
- Hedeker D & Gibbons RD (2006). Longitudinal Data Analysis. John Wiley & Sons, New York, USA.
- Iyit N & Genç A (2011). Constitution of random intercept and slope model (RISM) as a special case of linear mixed models (LMMs) for repeated measurements data. Applied Mathematics and Computation 218(3): 827-831.
- Kaps M & Lamberson WR (2004). Biostatistics for Animal Sciences. CABI Publishing, Cambridge, England.
- Littell RC, Miliken GA, Stroup WW, Wolfinger RD & Schabengberger O (2006). SAS for Mixed Models Second Edition. SAS Institute Inc., Cary, NC, USA. 814.
- Littell RC, Pendergast J & Natarajan R (2000). Modelling covariance structure in the analysis of repeated measures data. Statistics in Medicine 19: 1793-1819.
- Liu W & Yang Y (2011). Parametric or nonparametric? A parametricness index for model selection. The Annals of Statistics 39( 4): 2074–2102.

SAS (2014). SAS/STAT. Statistical analysis system for Windows. Release 9.4. SAS Institute Inc.

Ser G (2012). Determination of appropriate covariance structures in random slope and intercept model applied in repeated measures. *The Journal of Animal & Plant Sciences* 22(3): 552-555.

Stroup WW, Milliken GA, Claassen EA & Wolfinger RD (2018). SAS for Mixed Models: Introduction and Basic Applications. SAS Institute Inc., Cary, NC, USA.

Wang Z & Goonewardene LA (2004). The use of mixed models in the analysis of animal experiments with repeated measures data. *Canadian Journal of Animal Science* 84:1-11.